

FFG
FORSCHUNG WIRKT.



Buildings, Heat Pumps and Distributed Energy Storage Systems

Hermann Halozan

Graz University of Technology, Austria

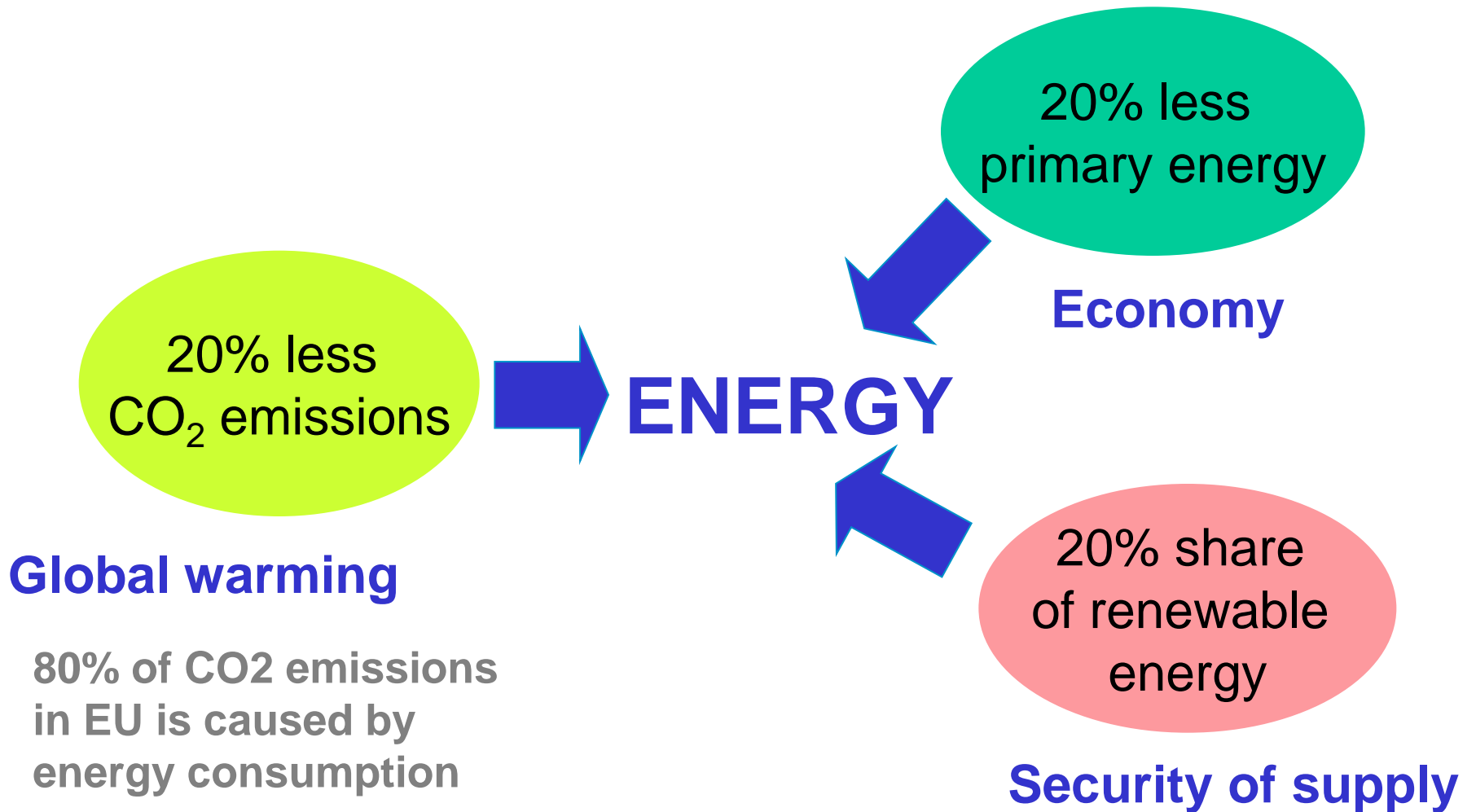

The Greenhouse Effect

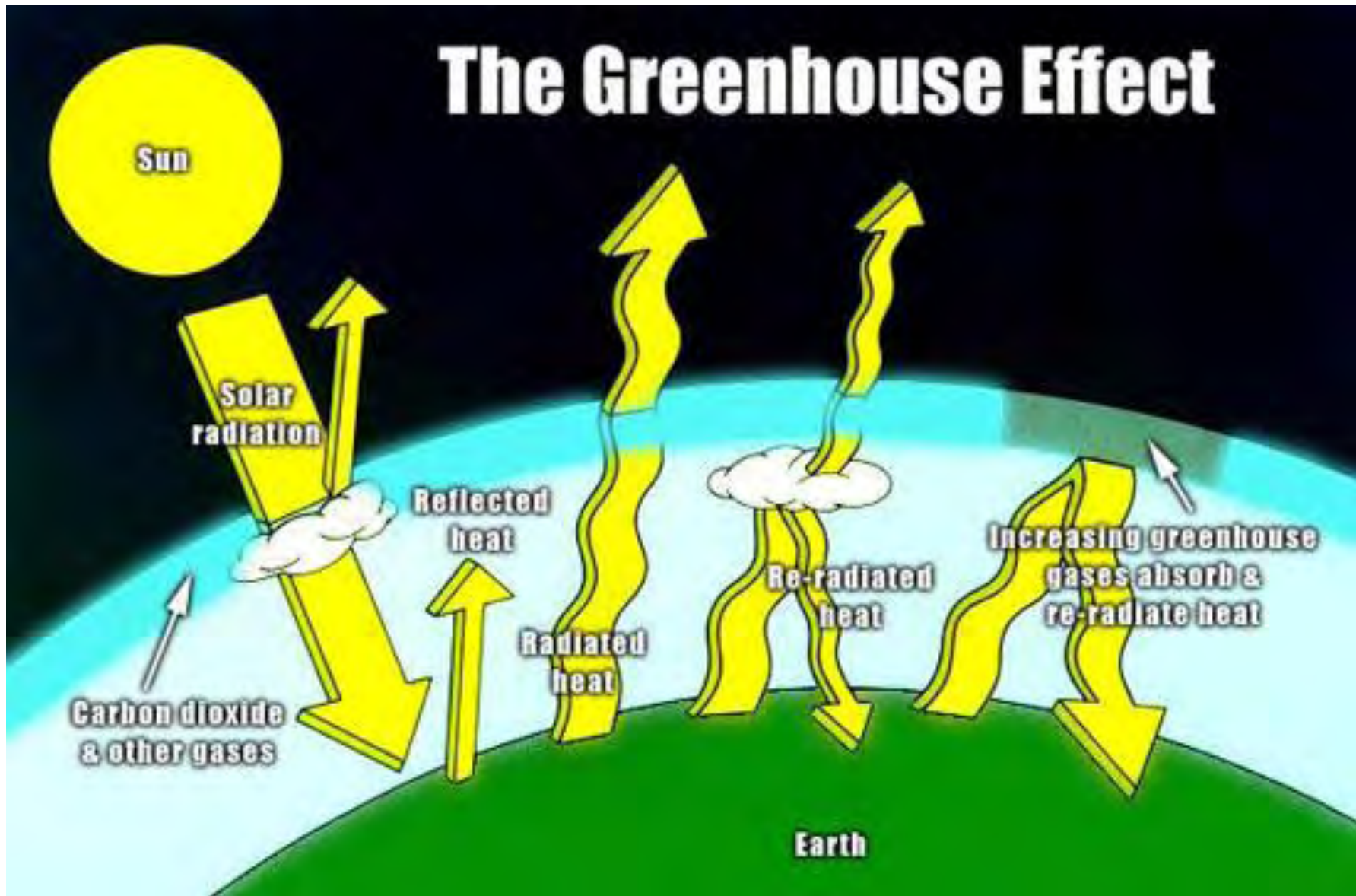



Carnot, Sadi (1796-1832)

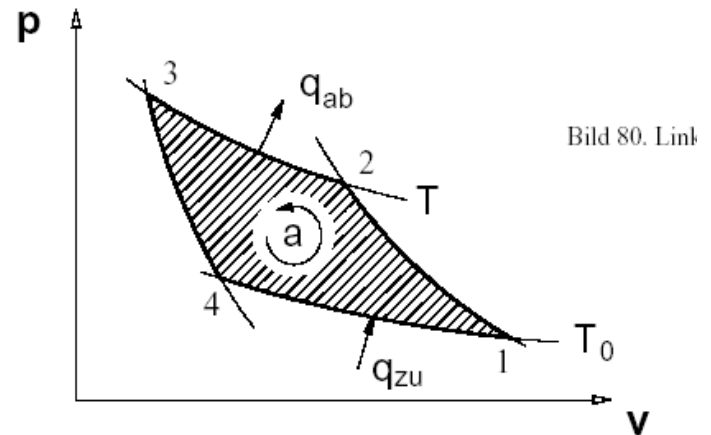
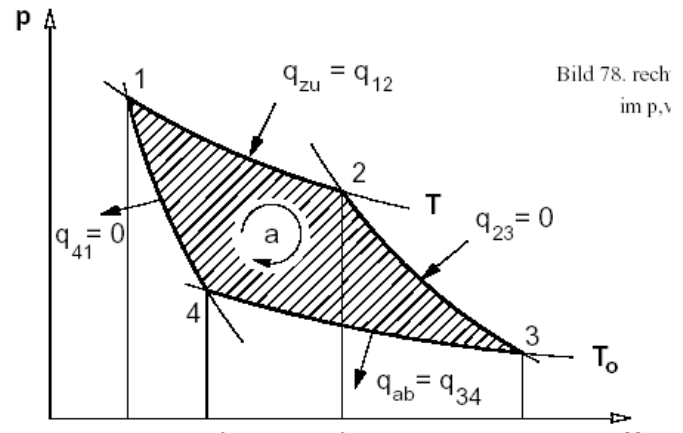

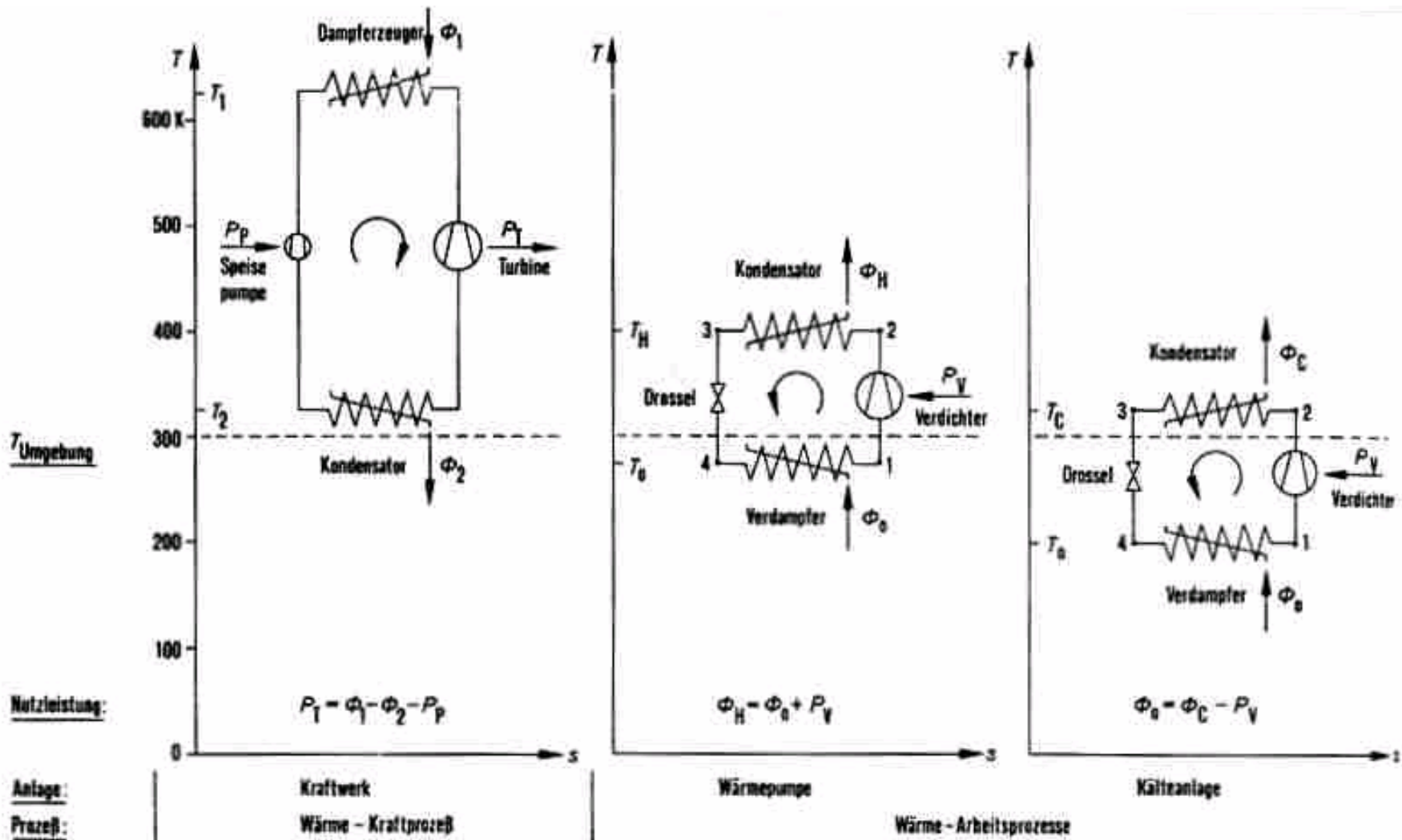

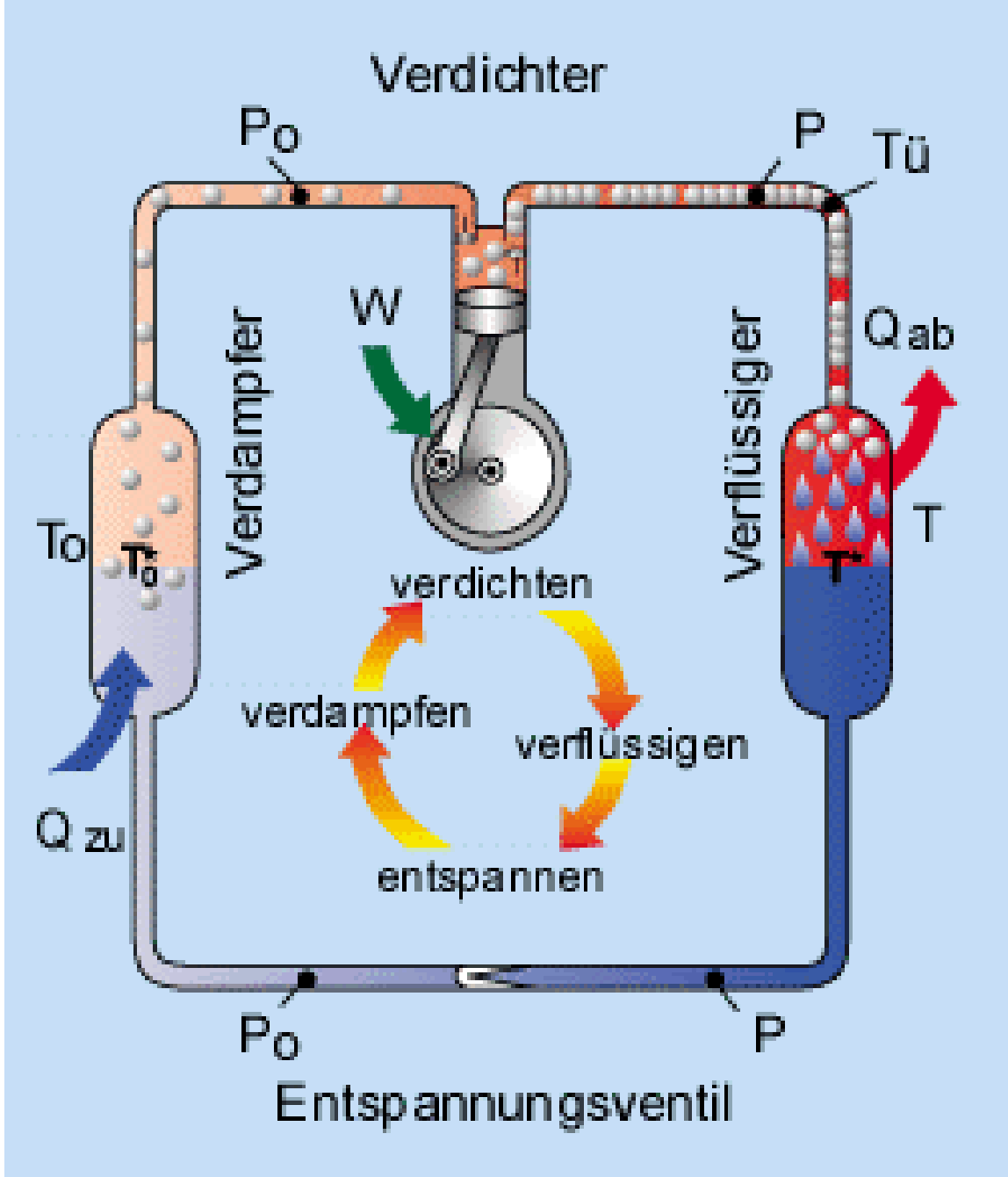

Energy- and Exergyflow in a Heat Pump

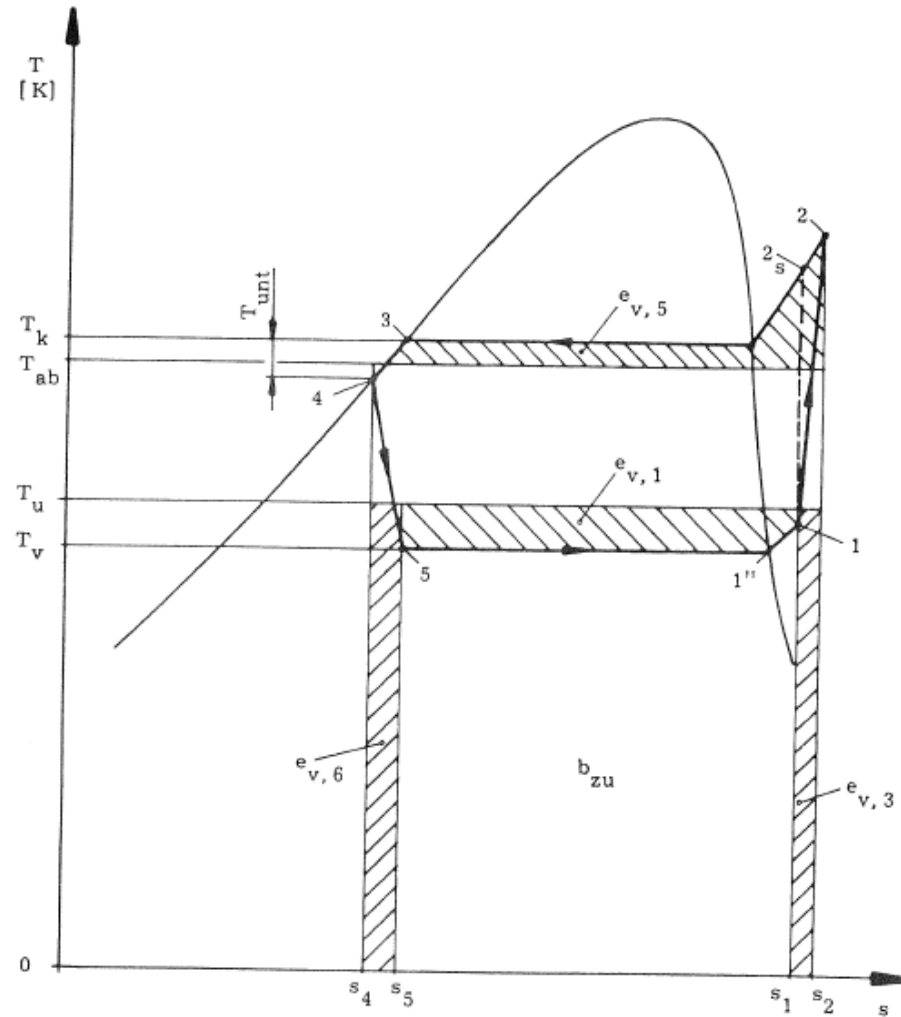
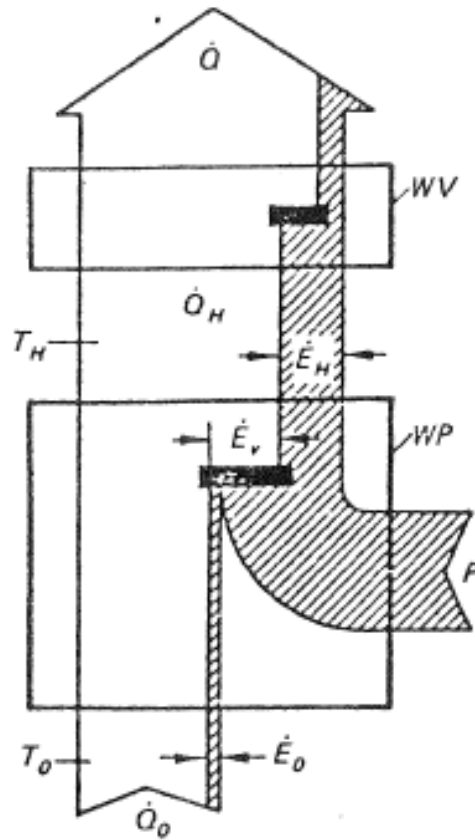

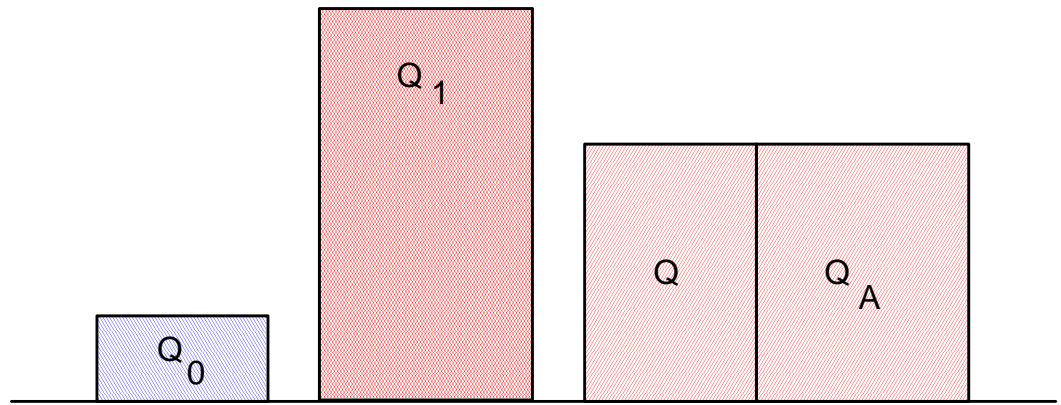
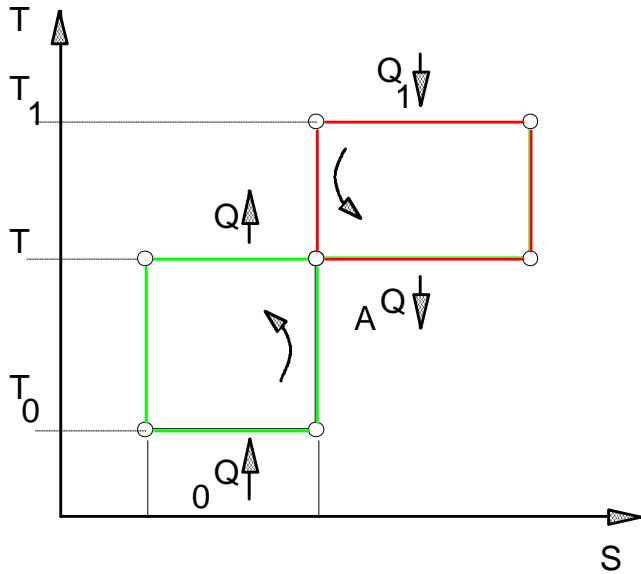
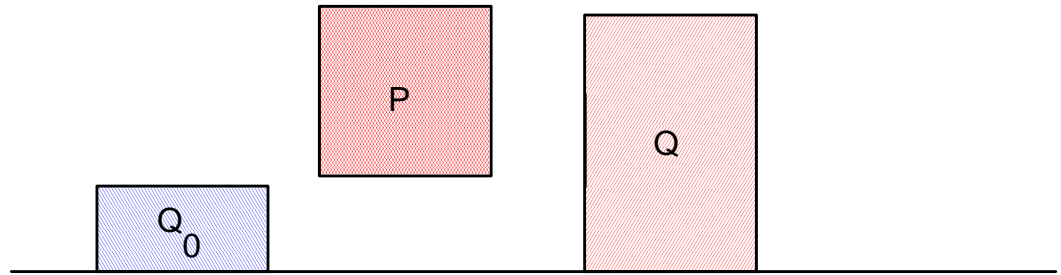
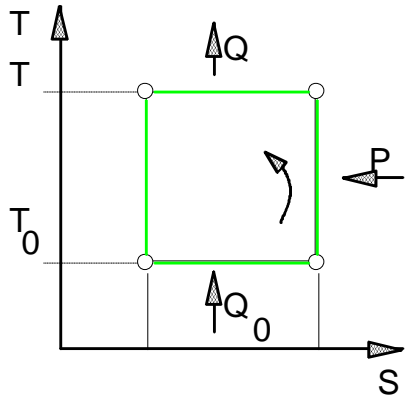



GRAZ68

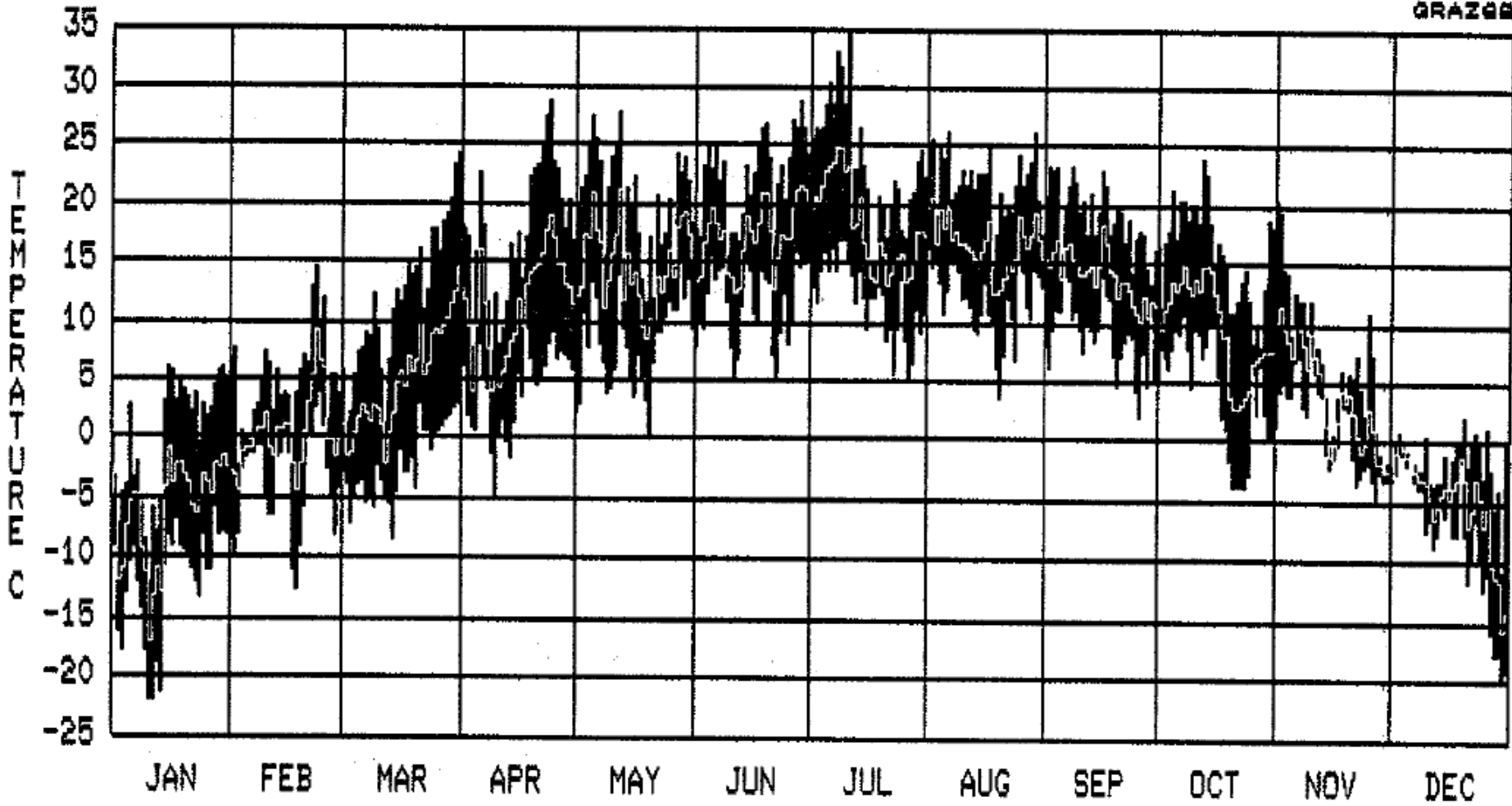

GRAZ68: YEARLY AVERAGE 8.35 C

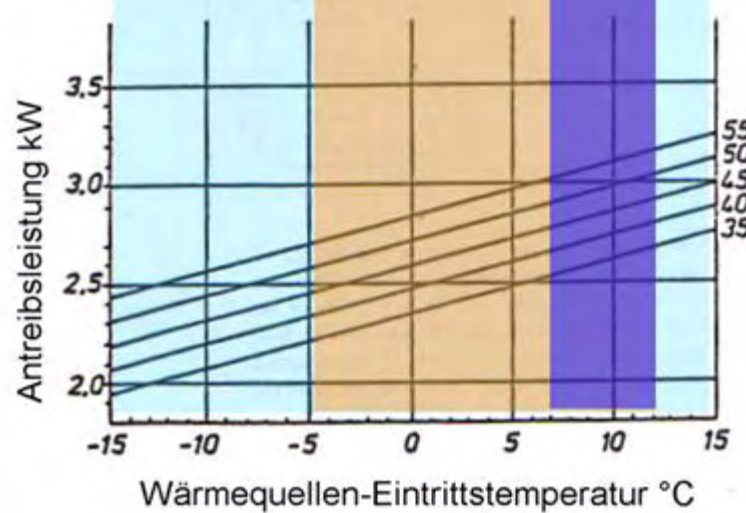
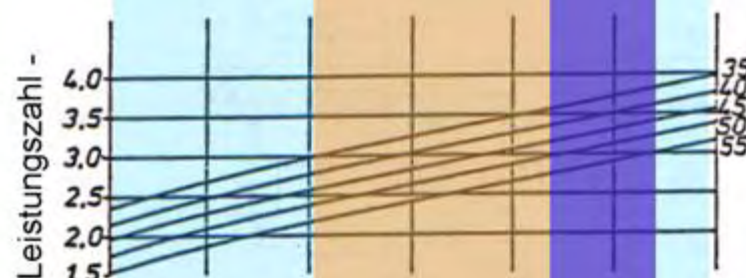
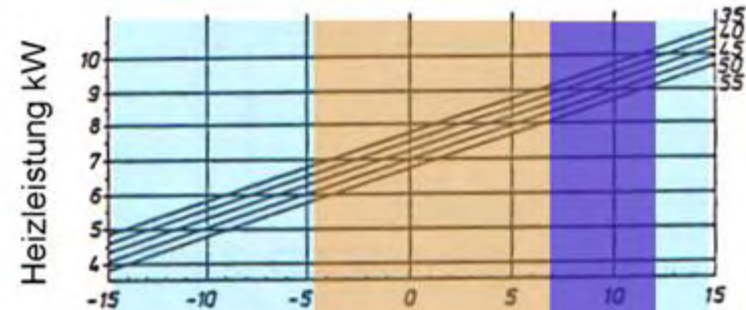
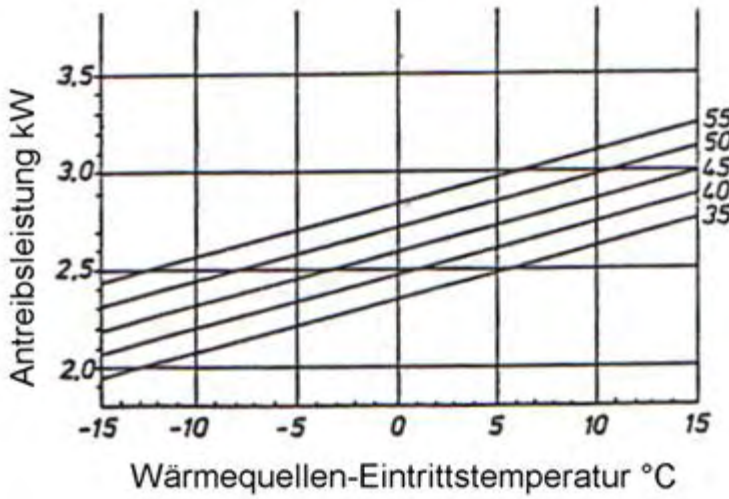
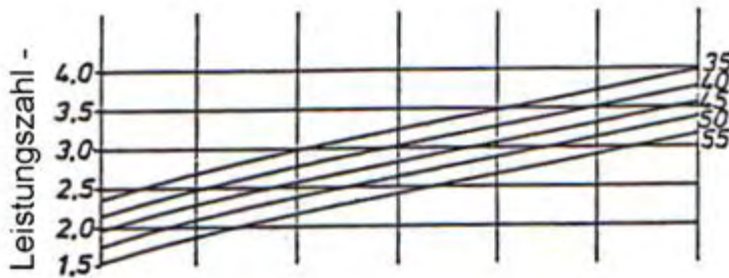
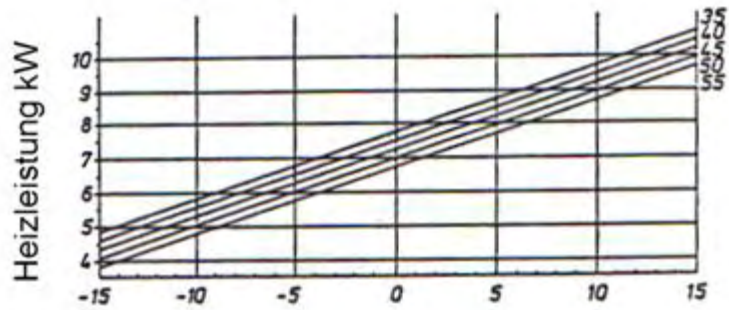



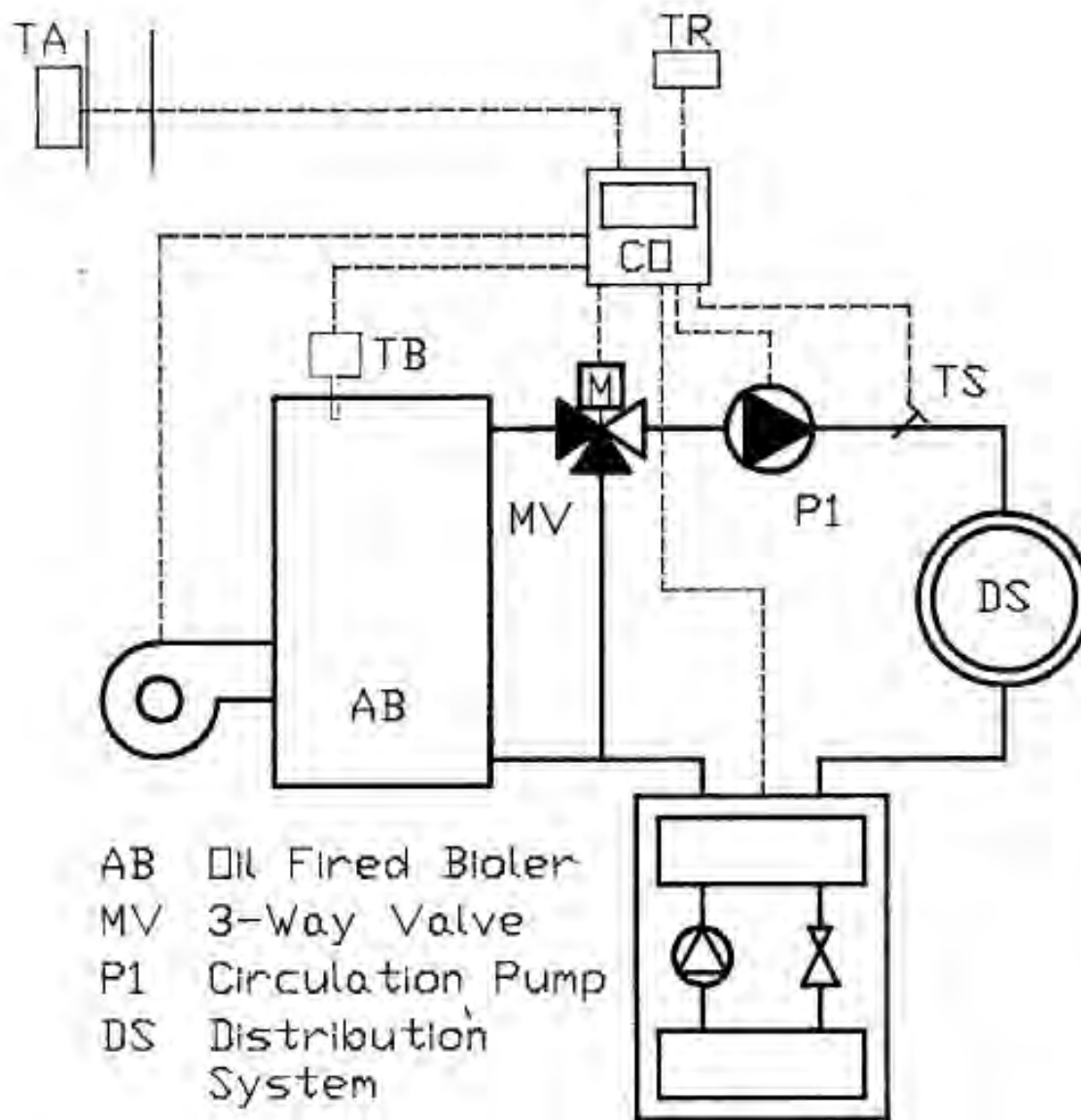

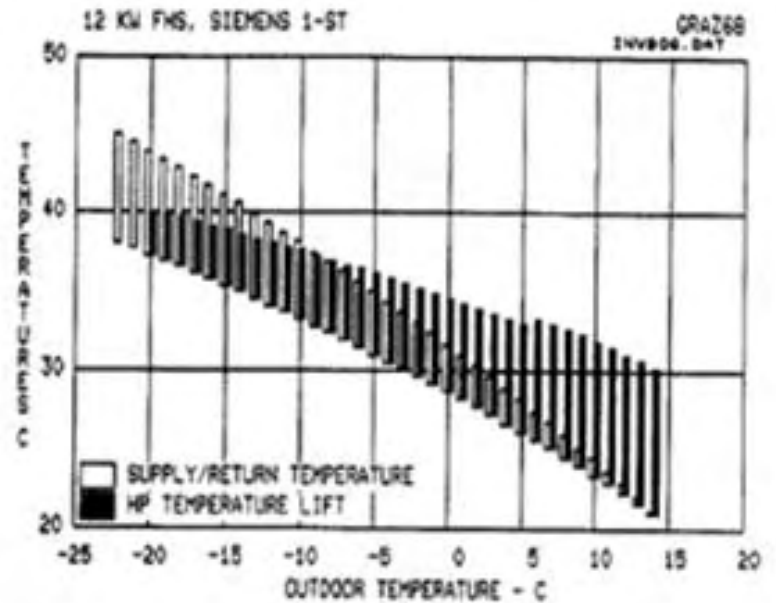
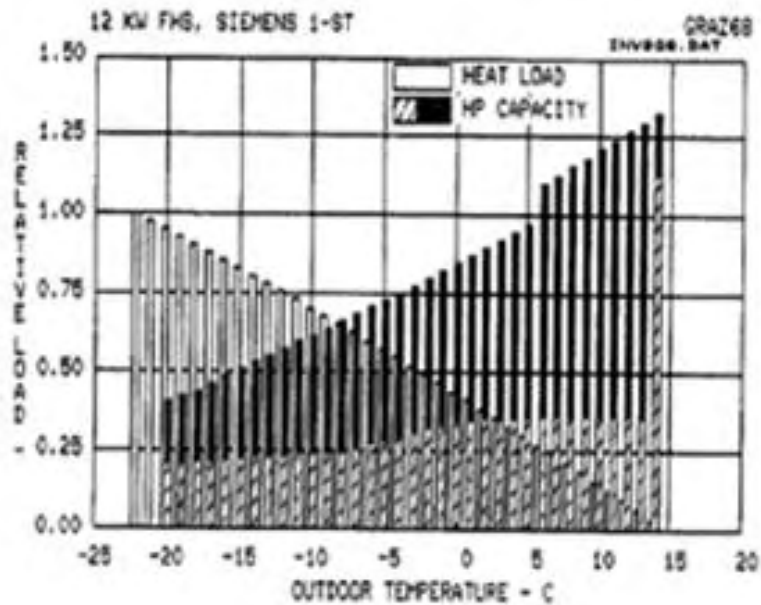

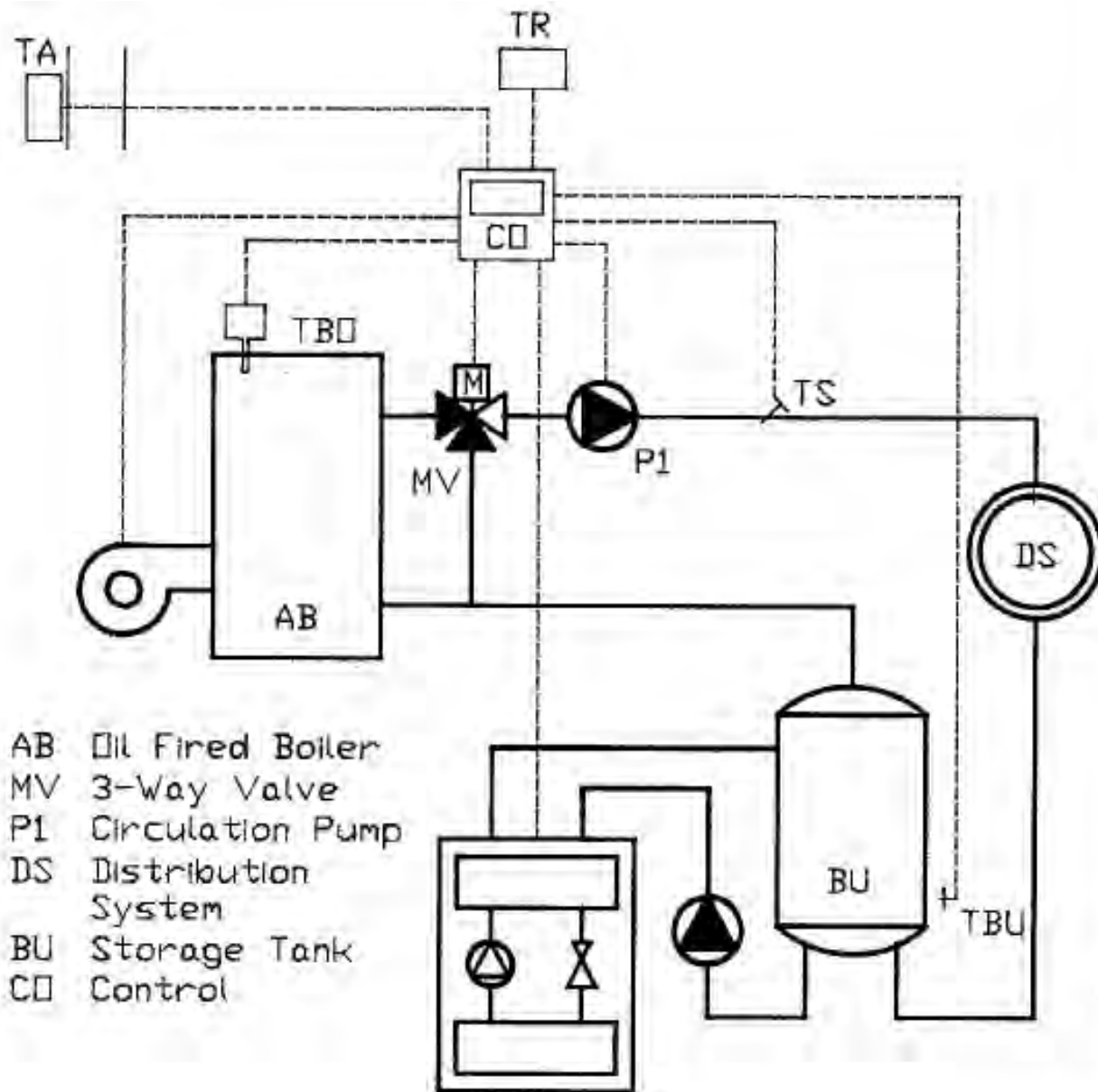

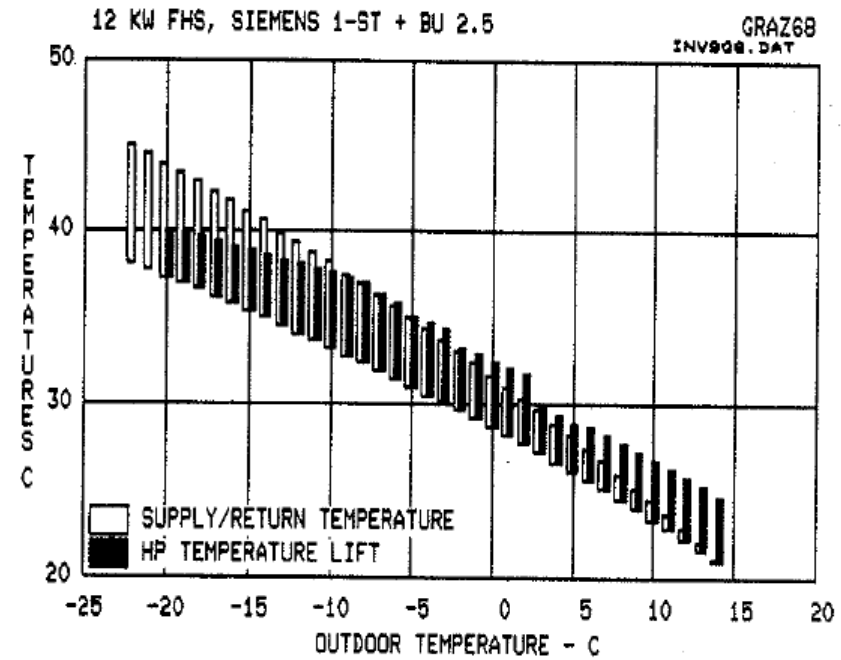
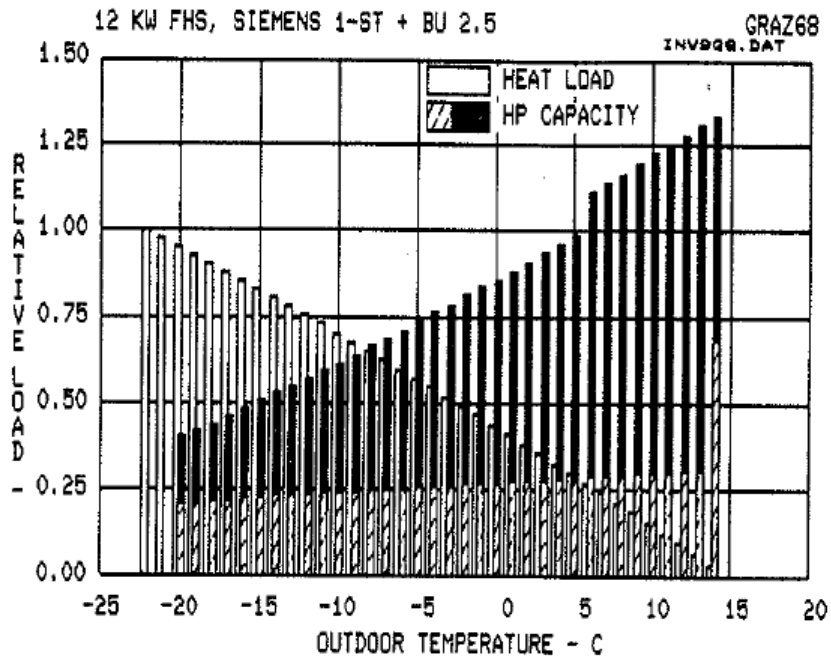

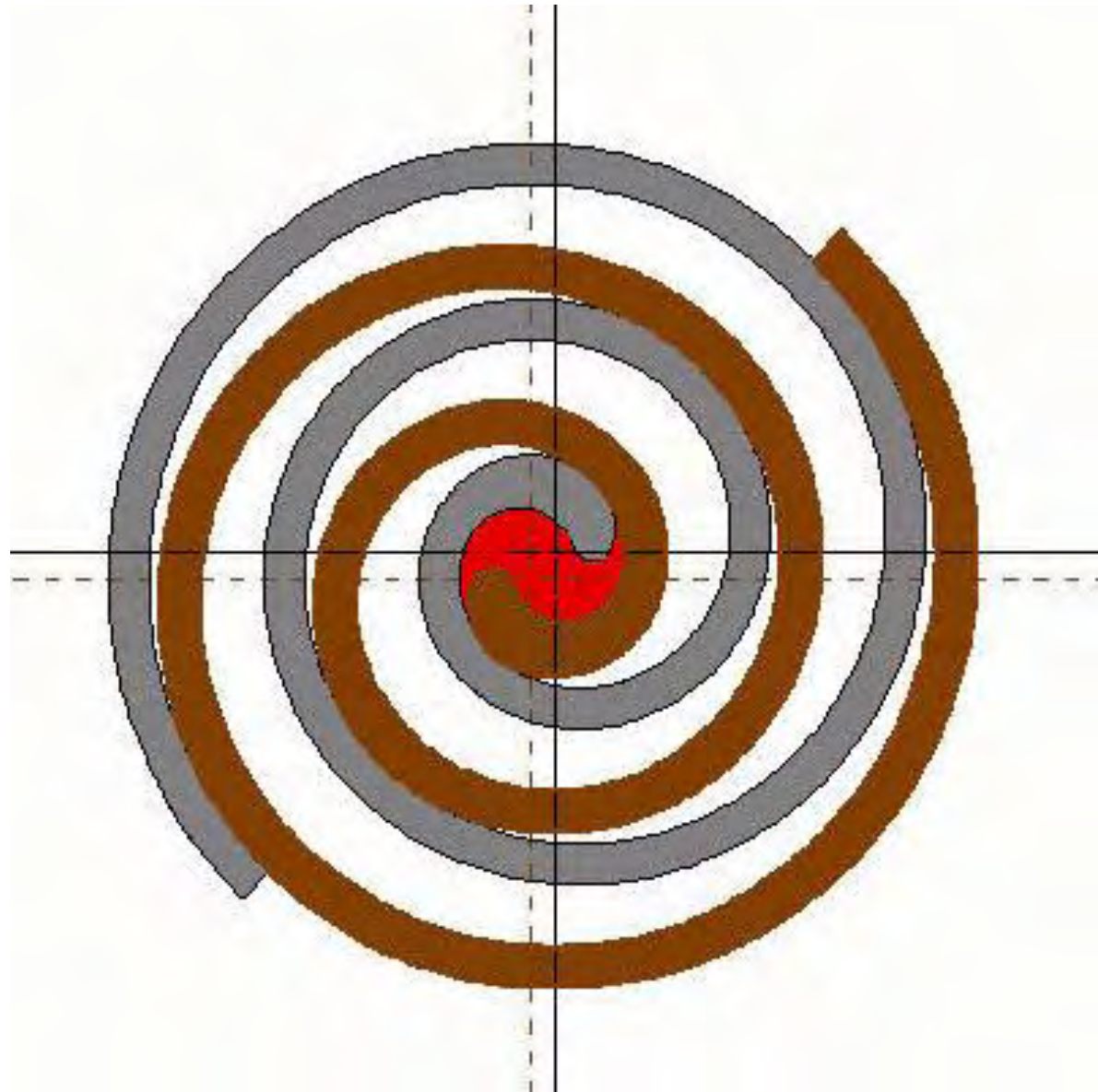
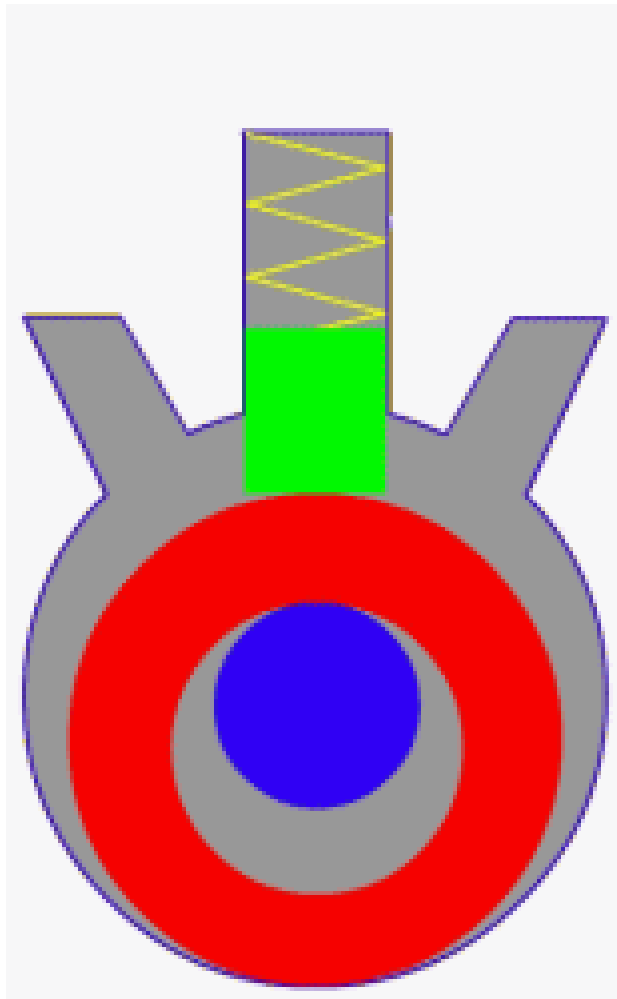

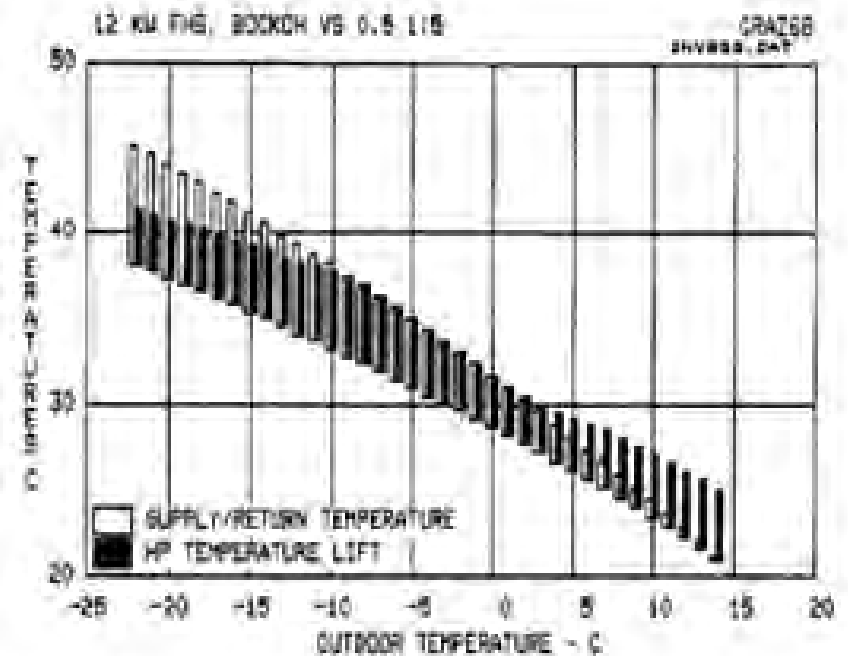
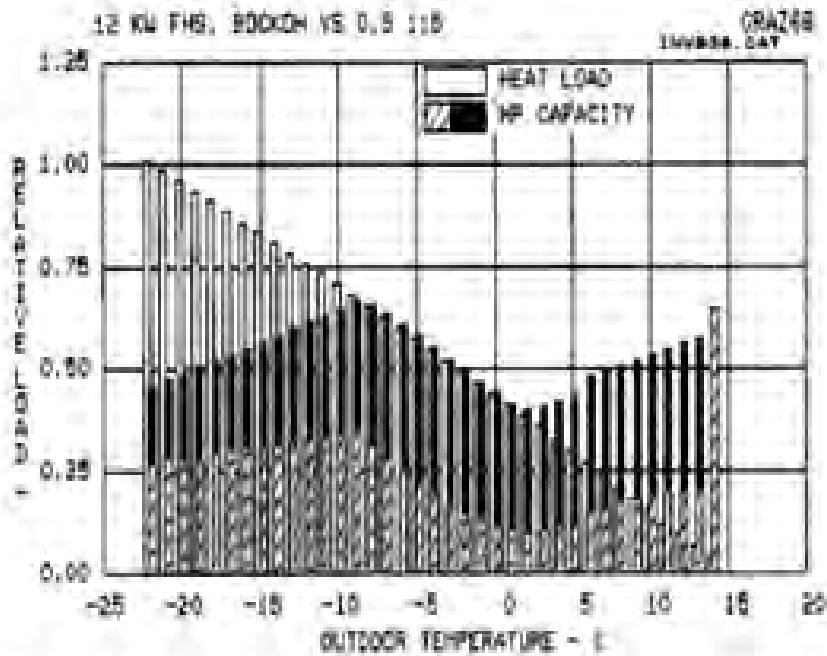

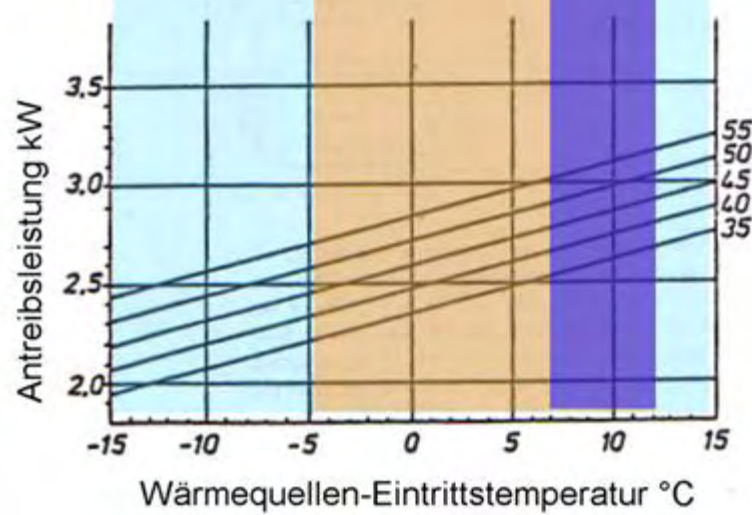
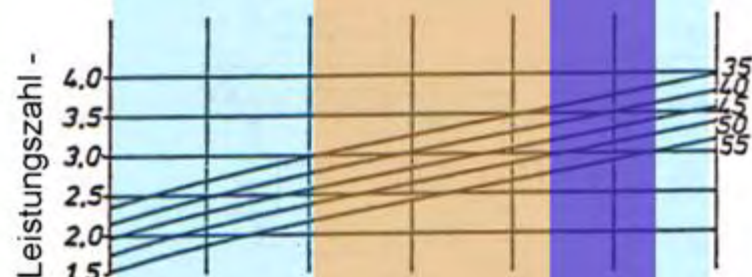
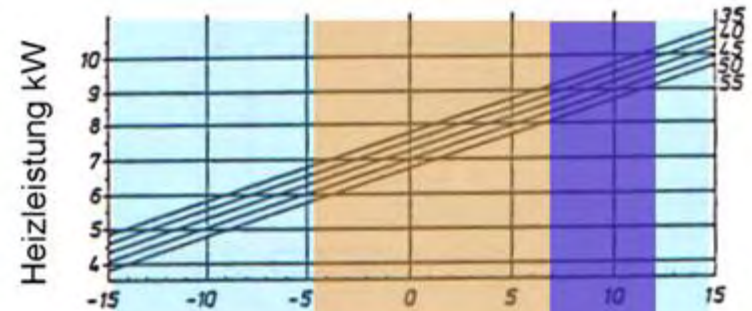
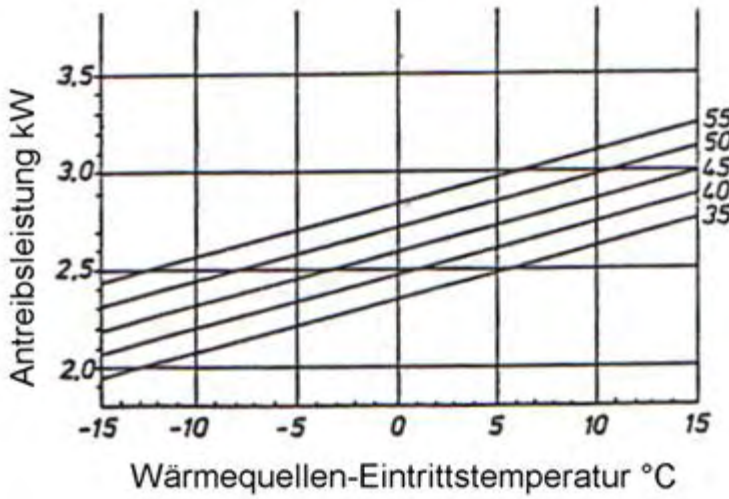
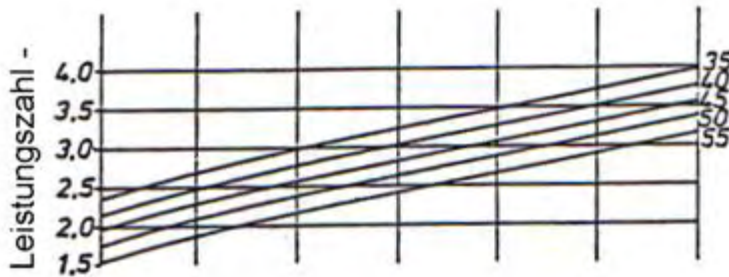
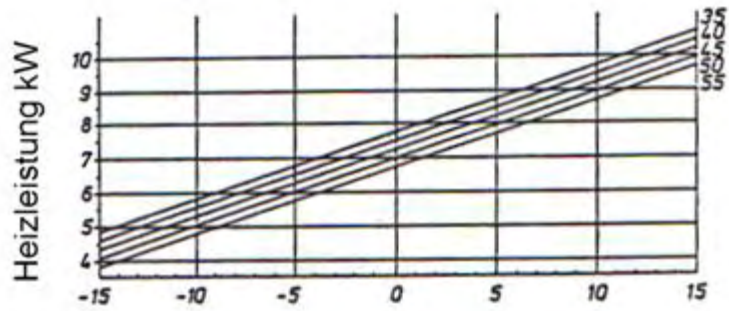

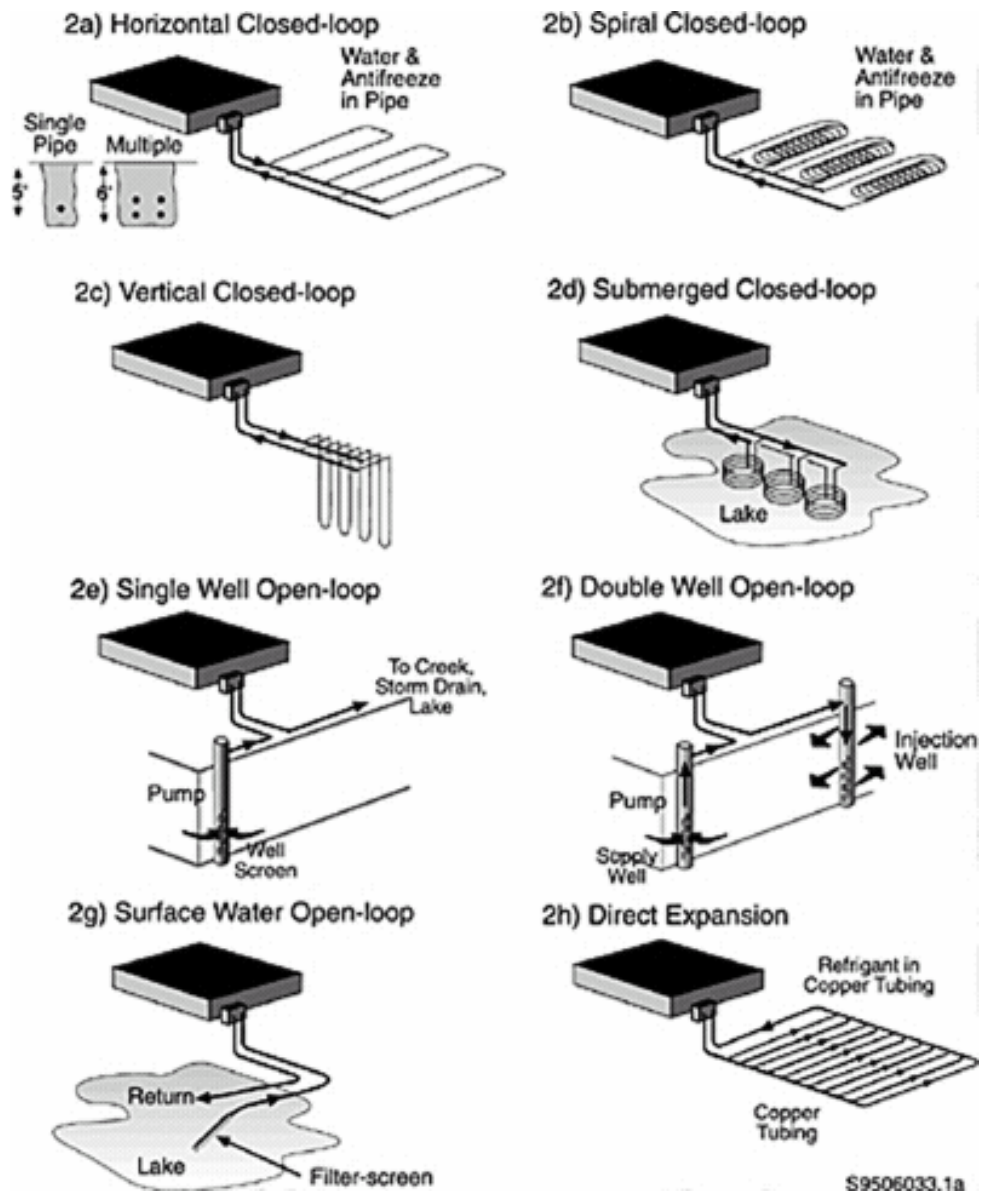

S9506033.1a

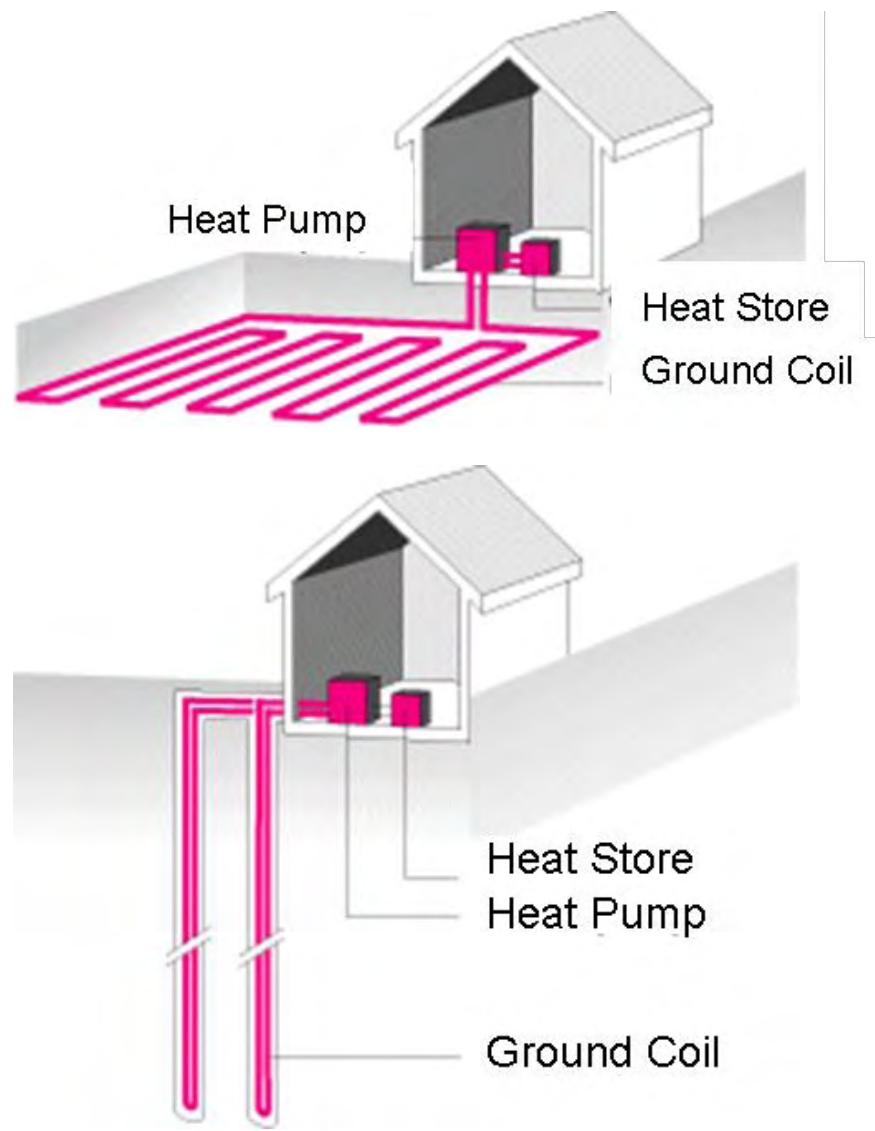

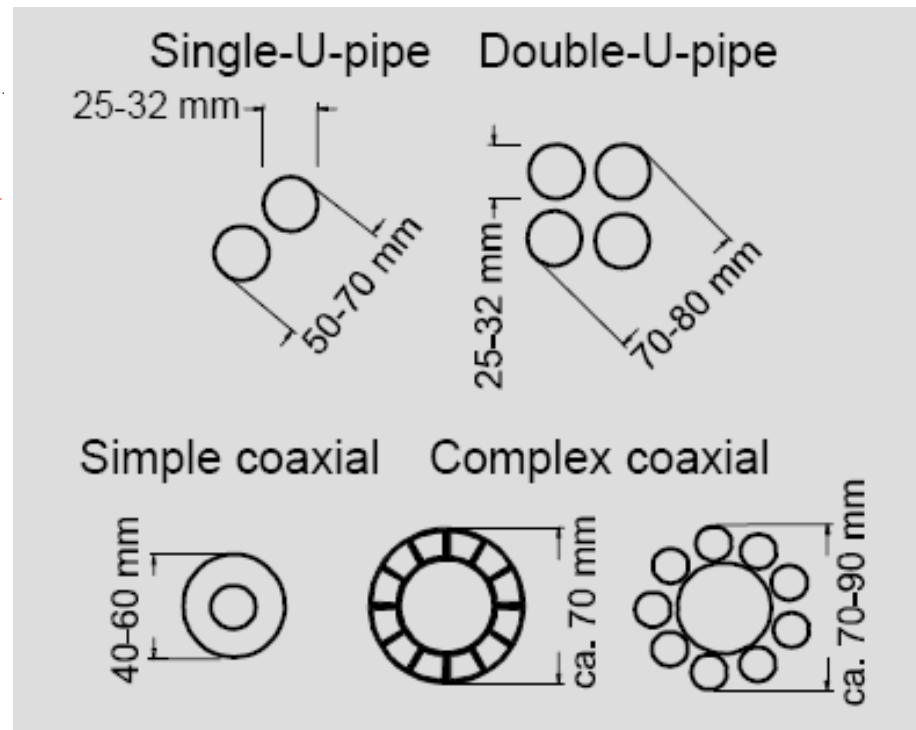
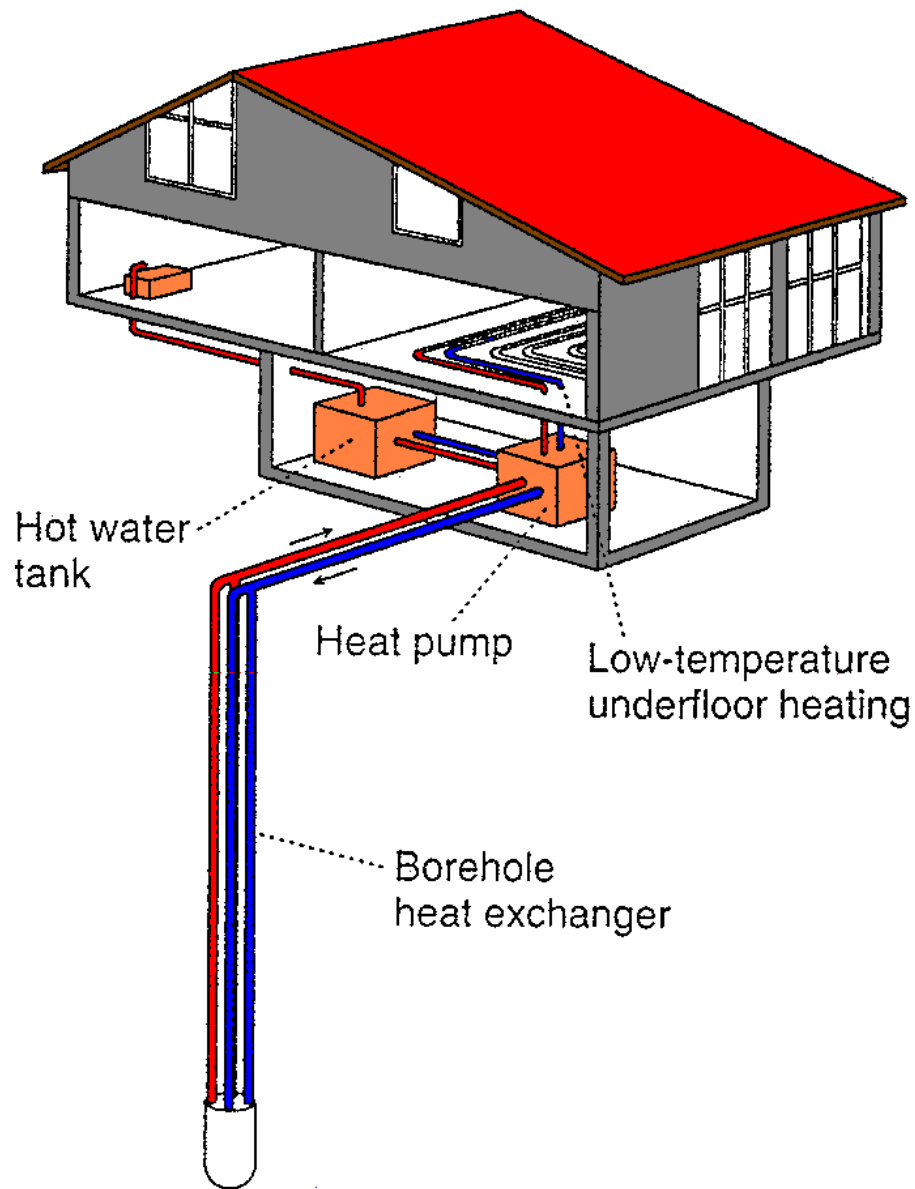

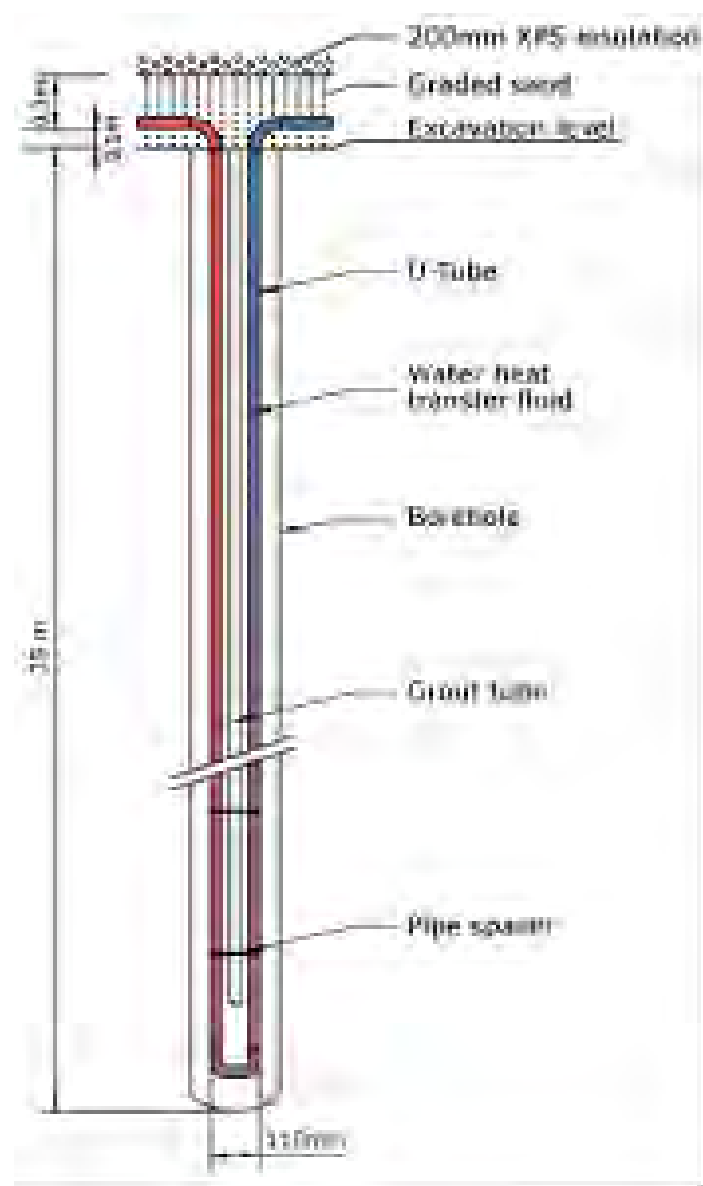
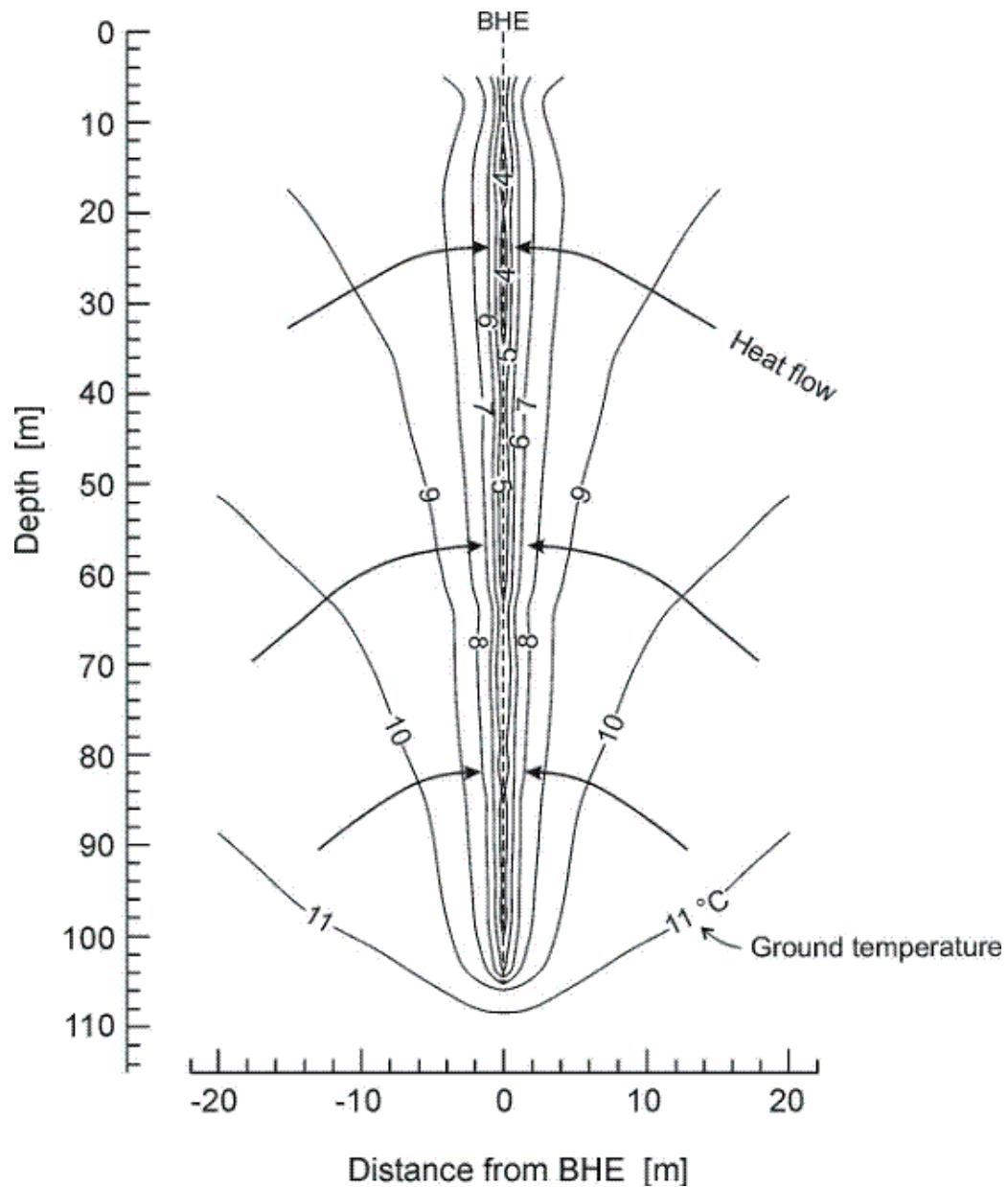

12 KW LTS, BOILER + W/W HEAT PUMP, 3.0 HP, CS GRAZ68
INV03.DAT

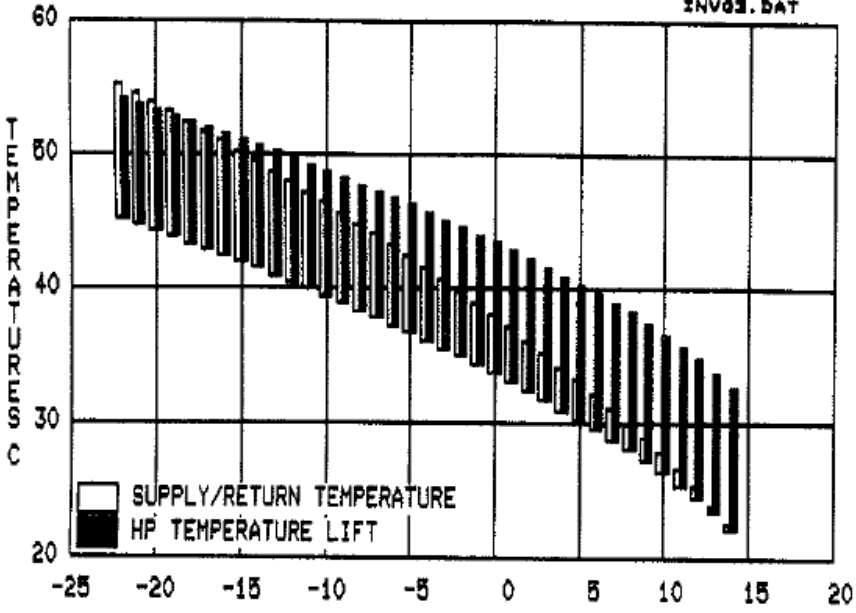

12 KW LTS, BOILER + W/W HEAT PUMP, 3.0 HP, CS GRAZ68
INV03.DAT

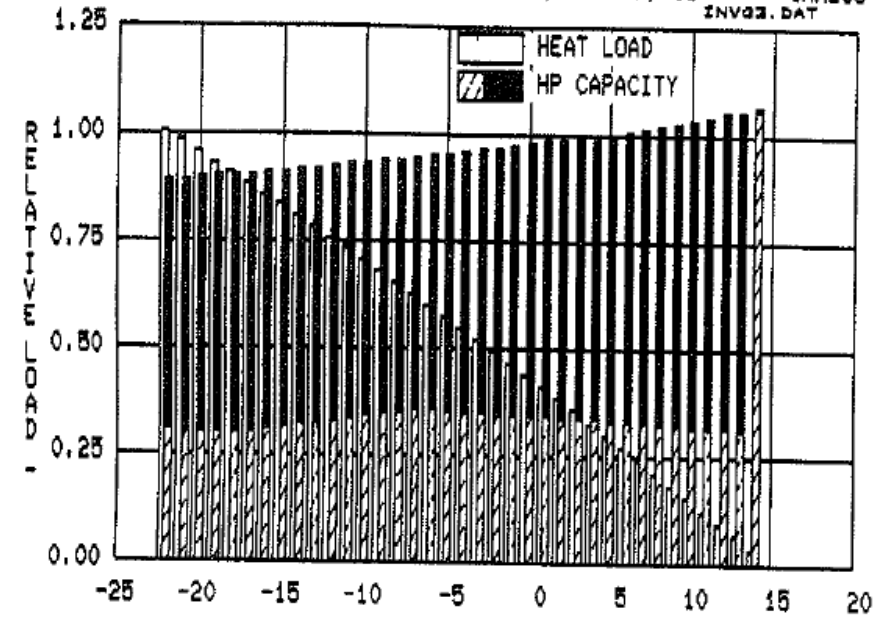

12 KW LTS, BOILER + W/W HEAT PUMP, 3.0 HP, VS 5.0 GRAZ68
INVQ3.DAT

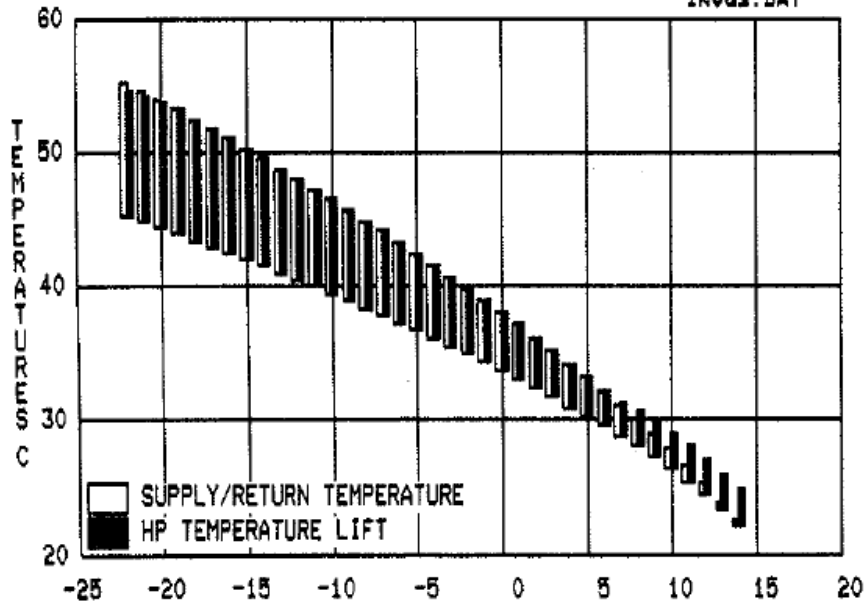

12 KW LTS, BOILER + W/W HEAT PUMP, 3.0 HP, VS 5.0 GRAZ68
INVQ3.DAT

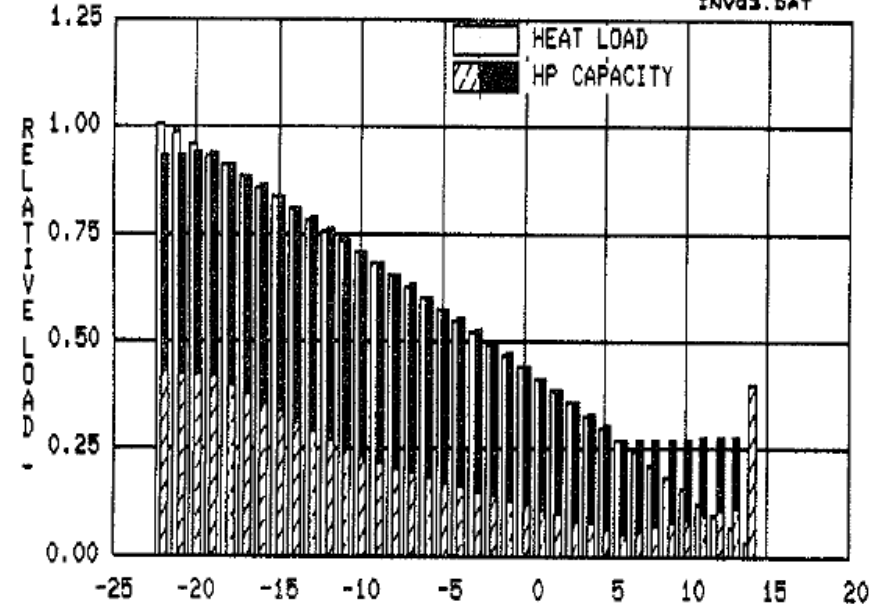

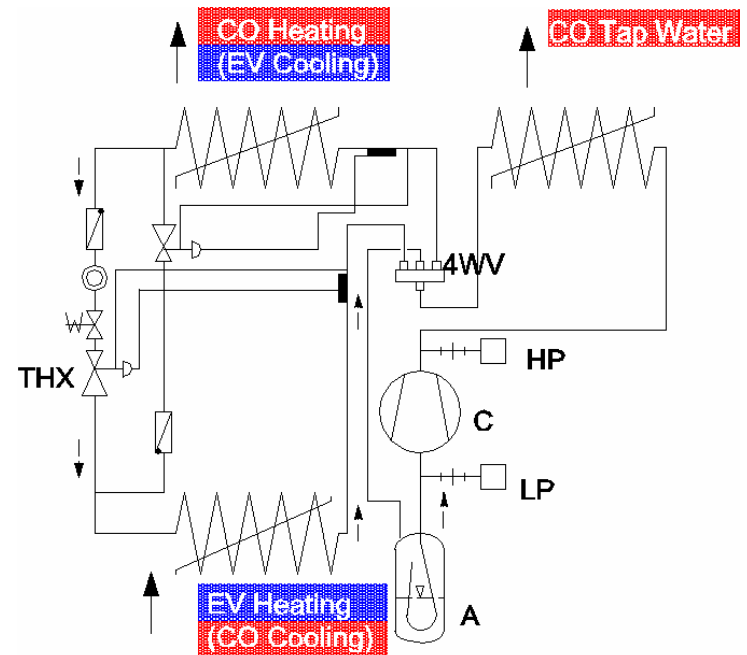
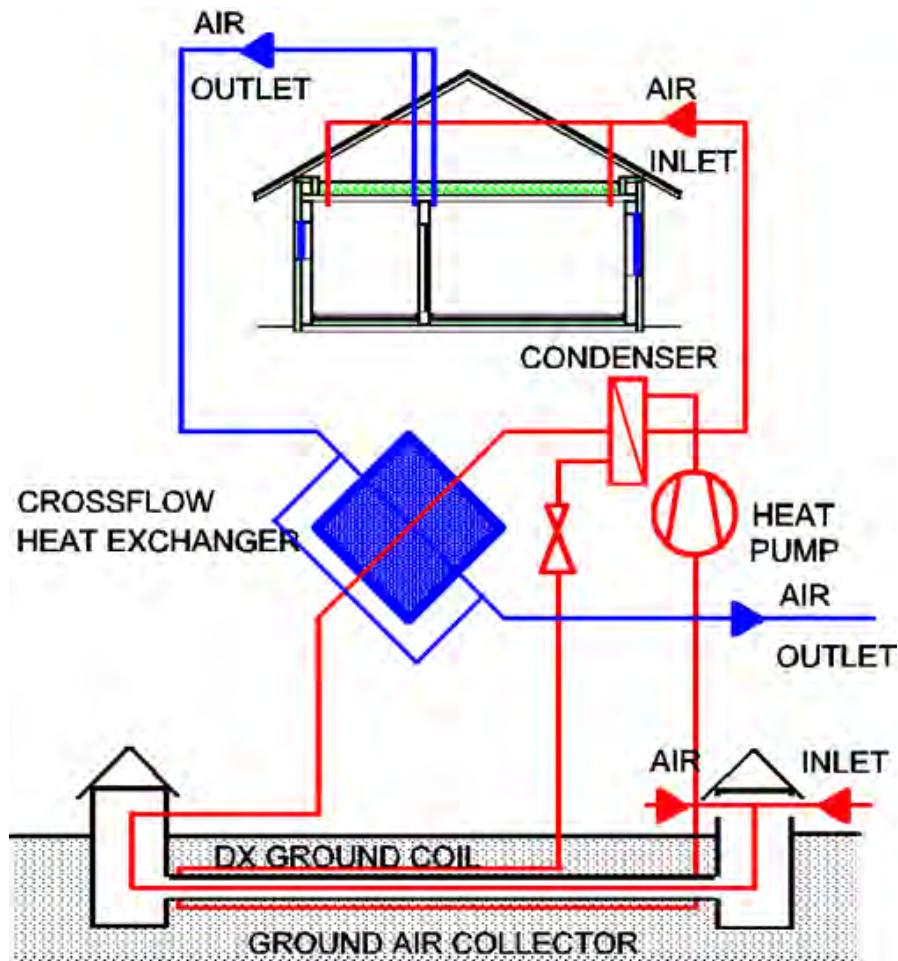

- C Compressor
- CO Condenser
- EV Evaporator
- A Accumulator
- THX Thermostatic Expansion Valve
- 4WV 4-Way Valve

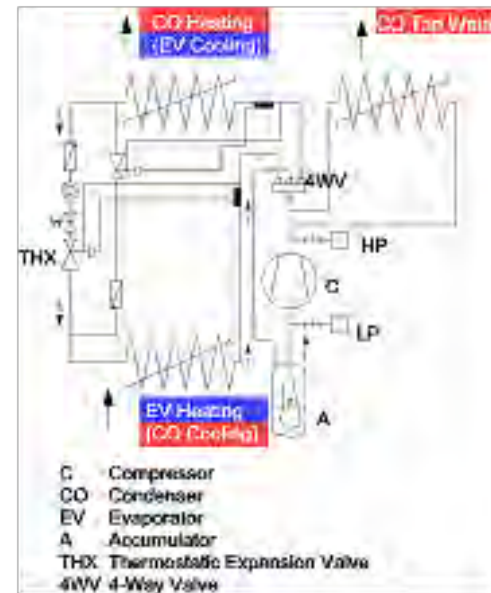
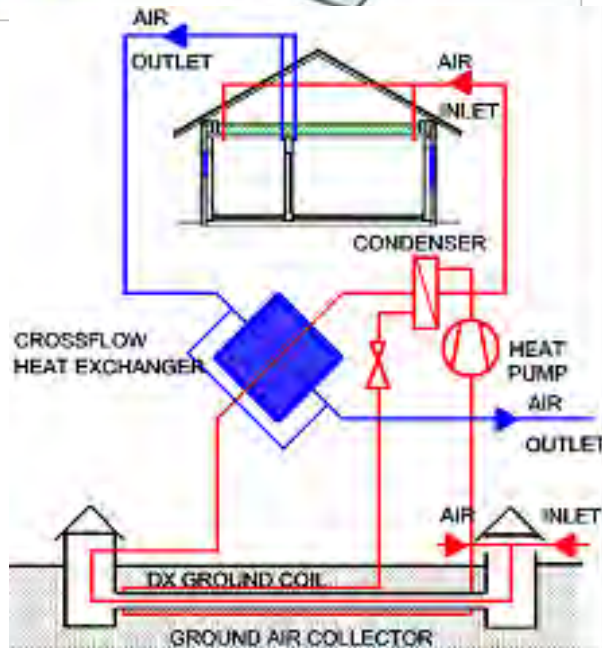
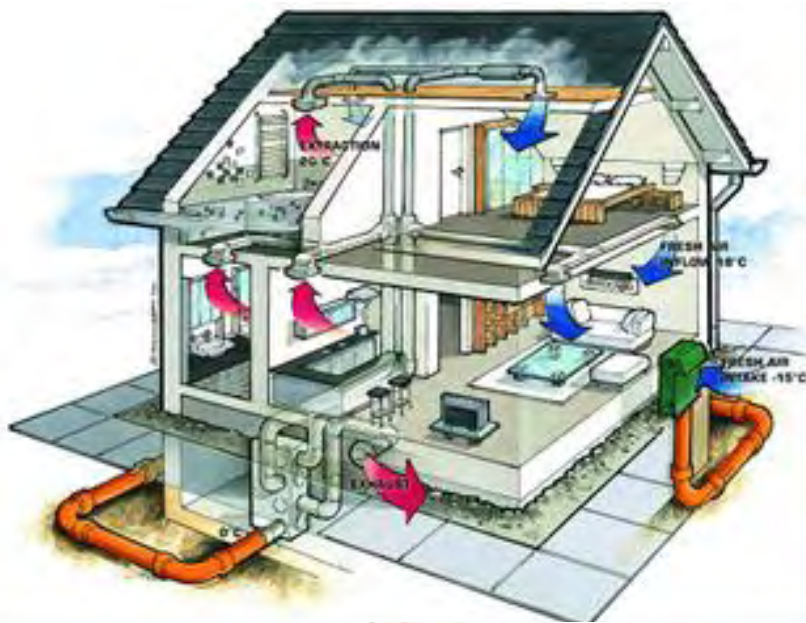

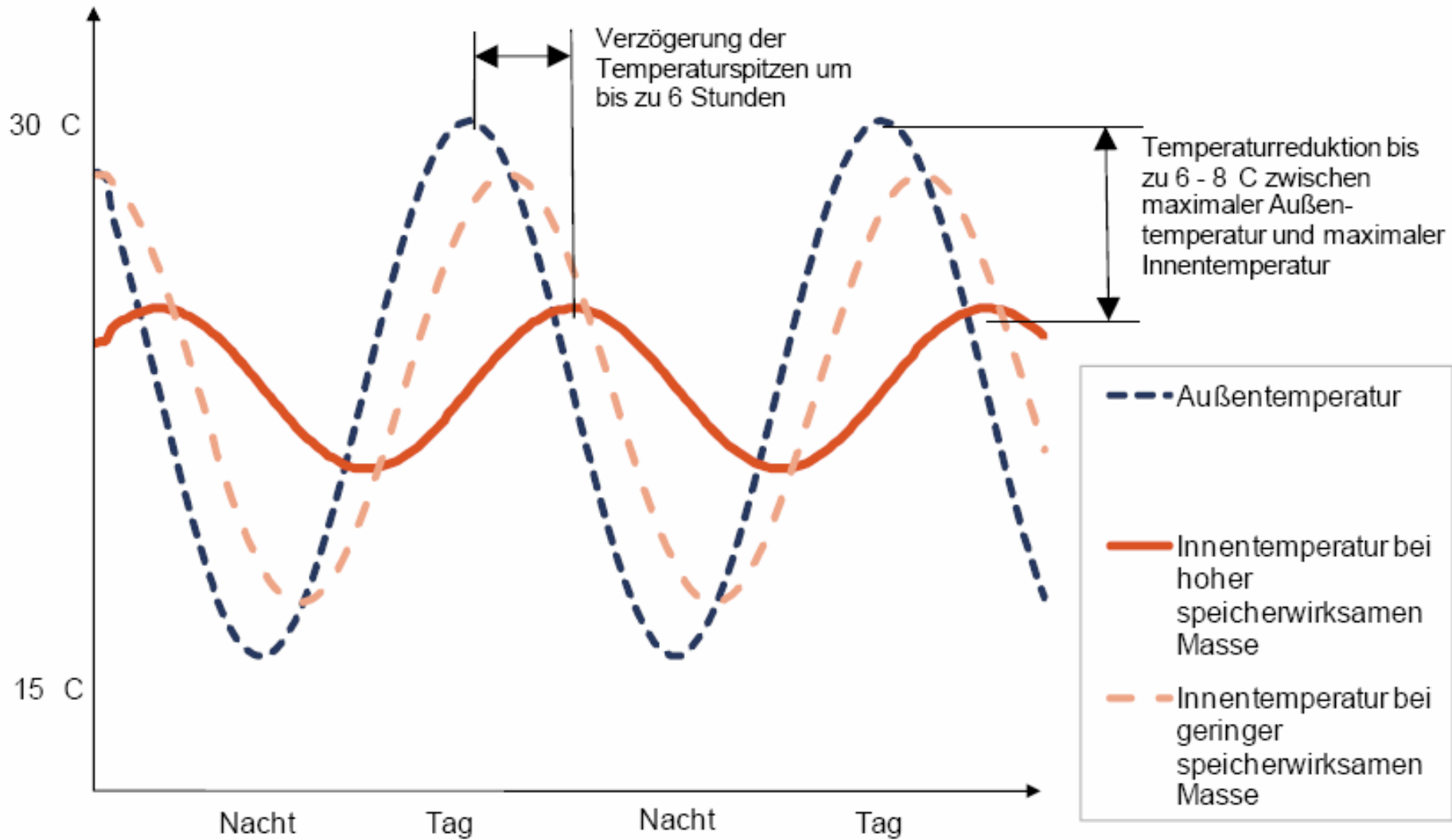

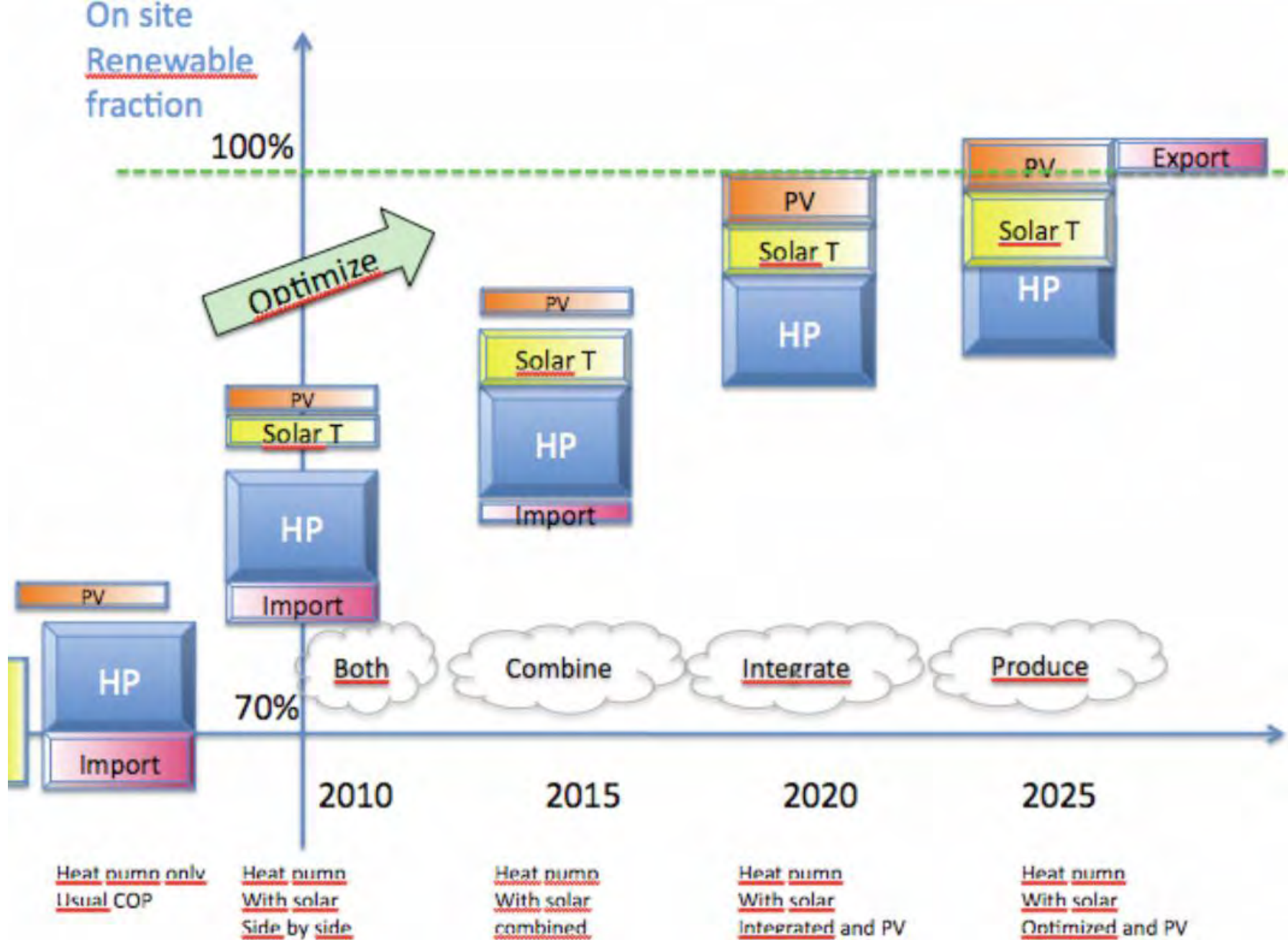

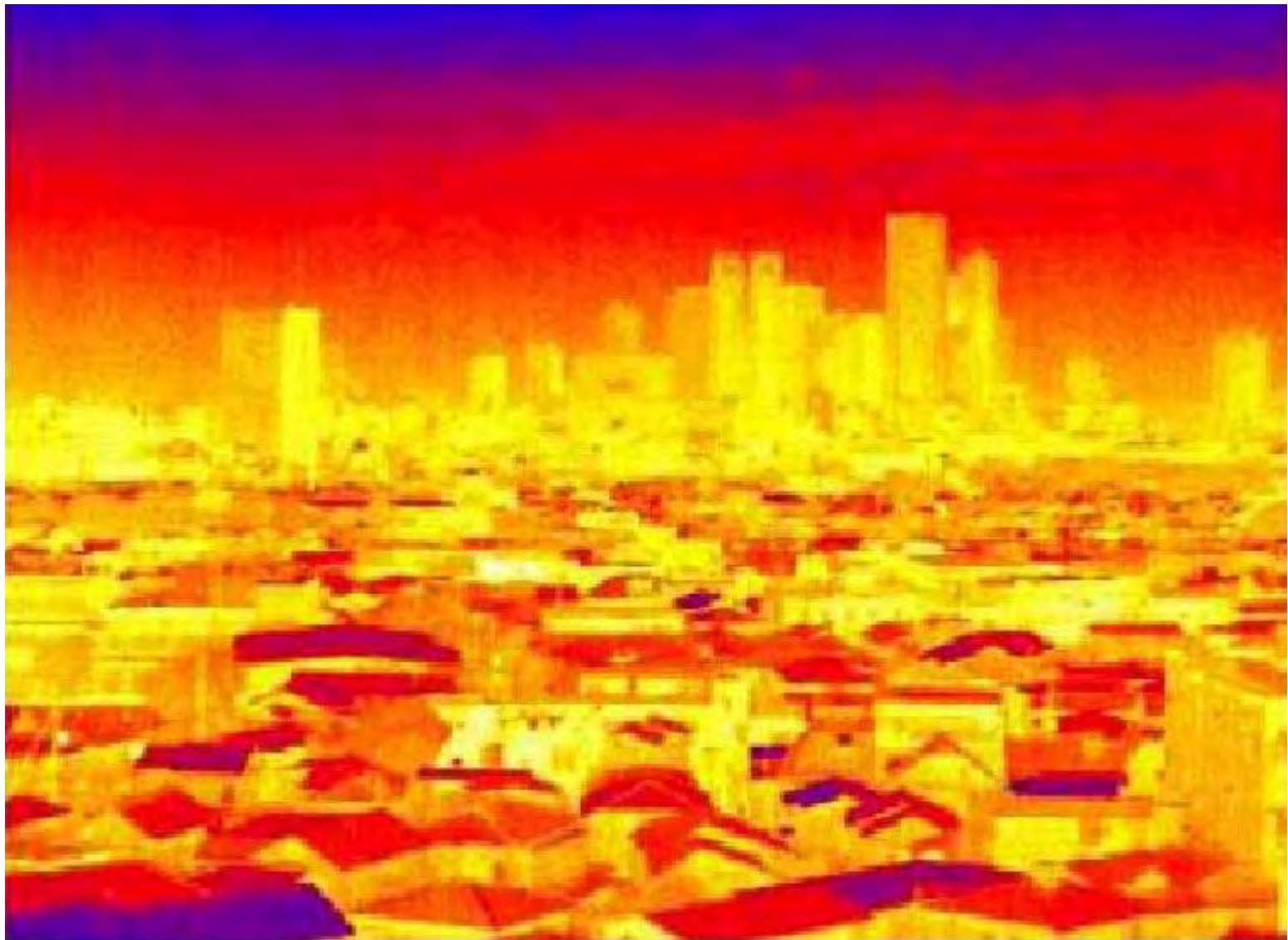

Heat Islands in Large Cities



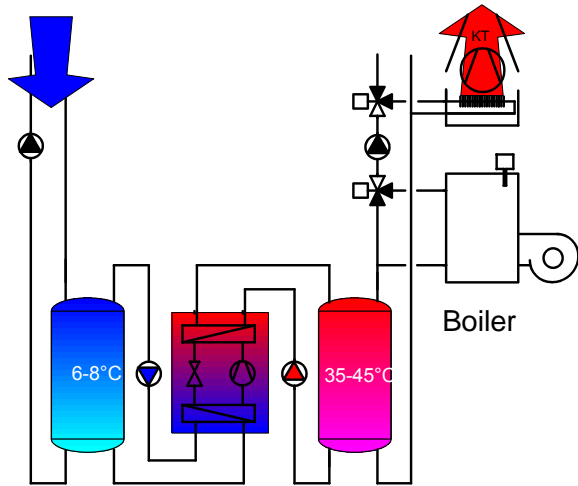
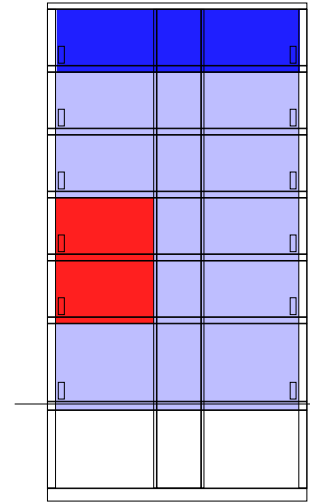
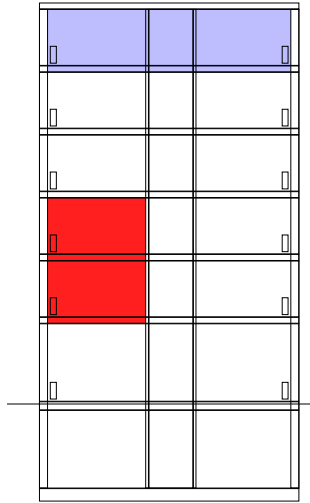
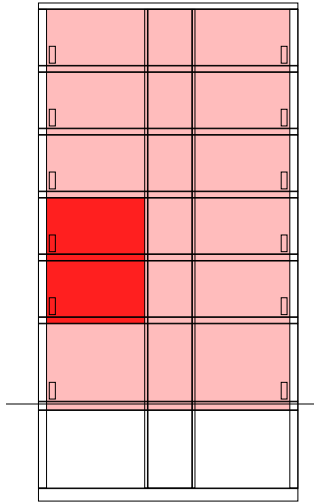

Cooling

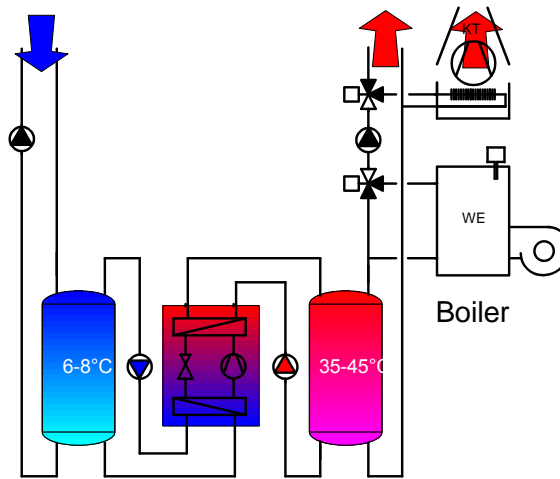

Cooling and Heating

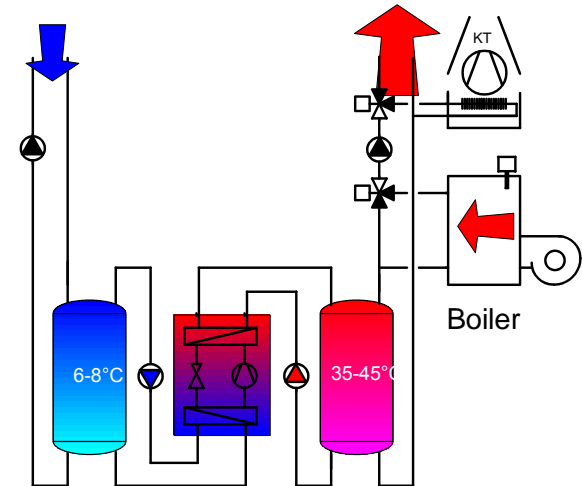

Heating

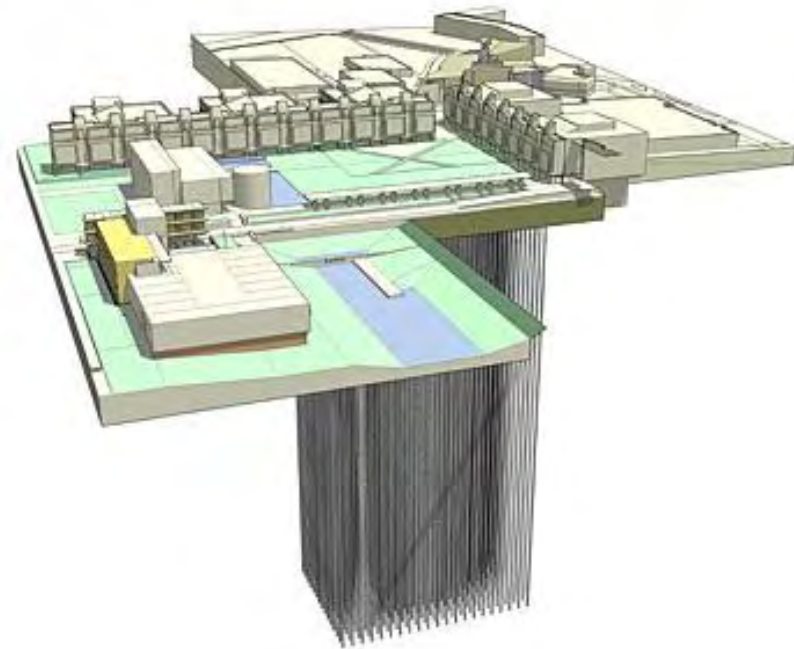
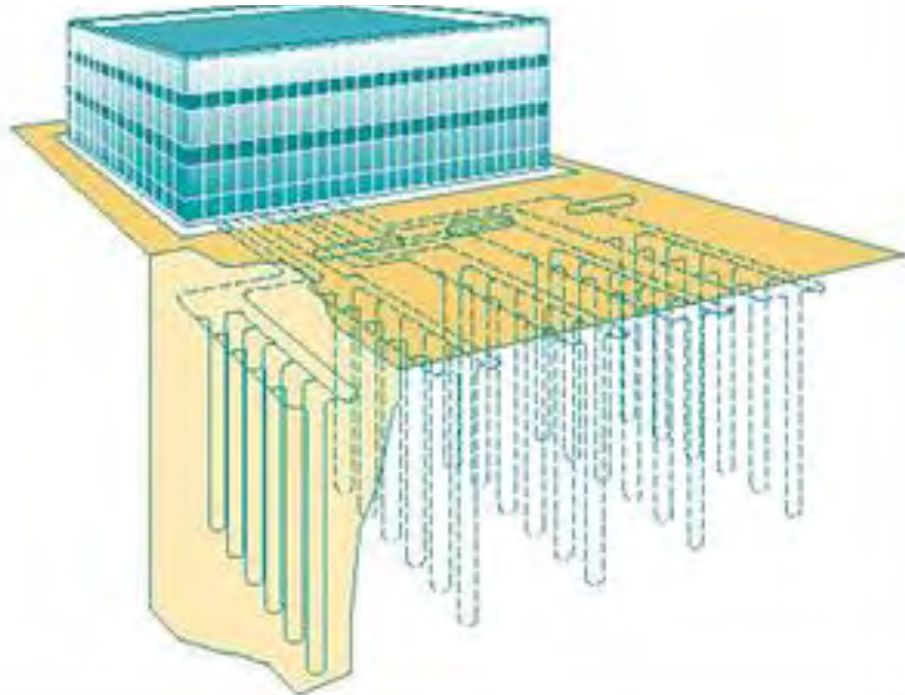
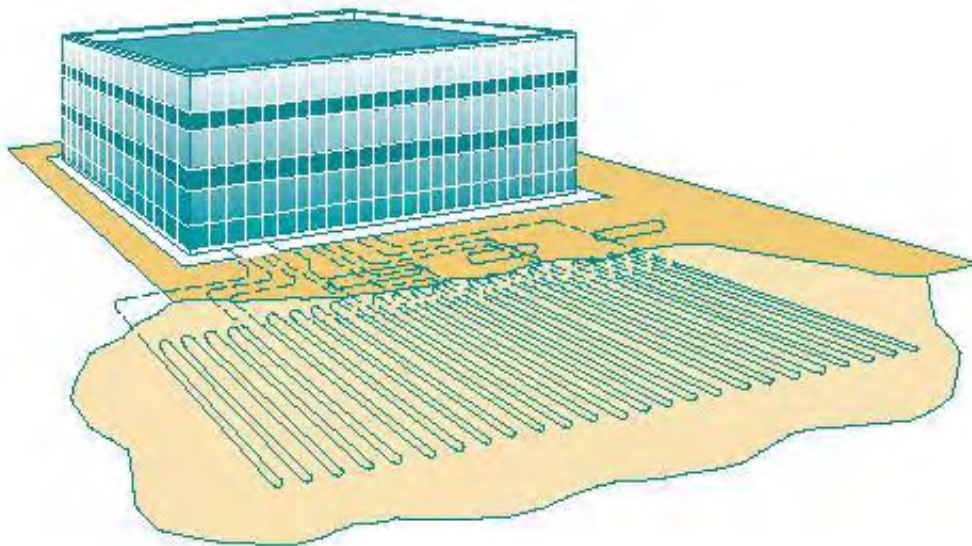

Gründung von Hochhäusern

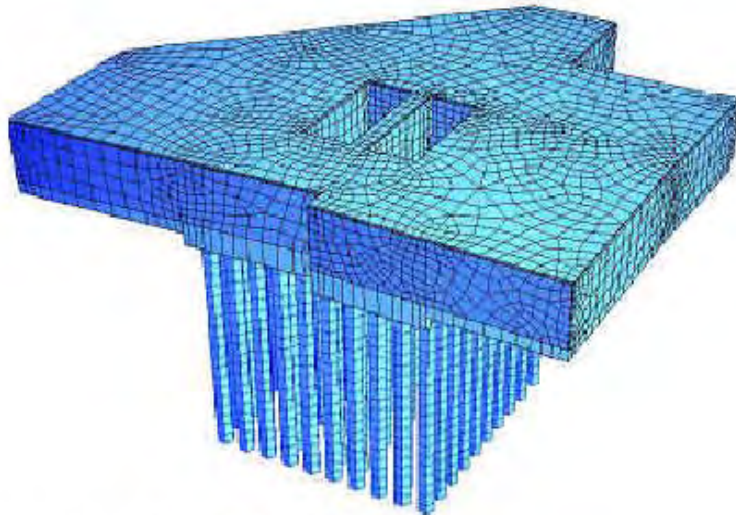
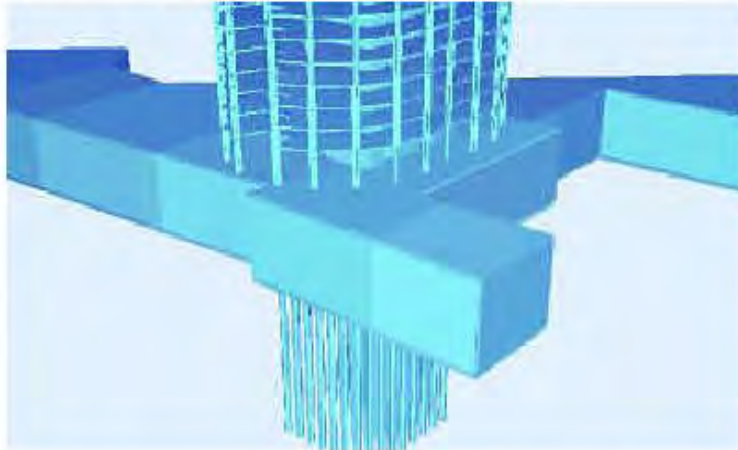

Hochhaus MAX, Frankfurt / Main
(A: Murphy/Jahn, I: Werner Sobek Ingenieure)

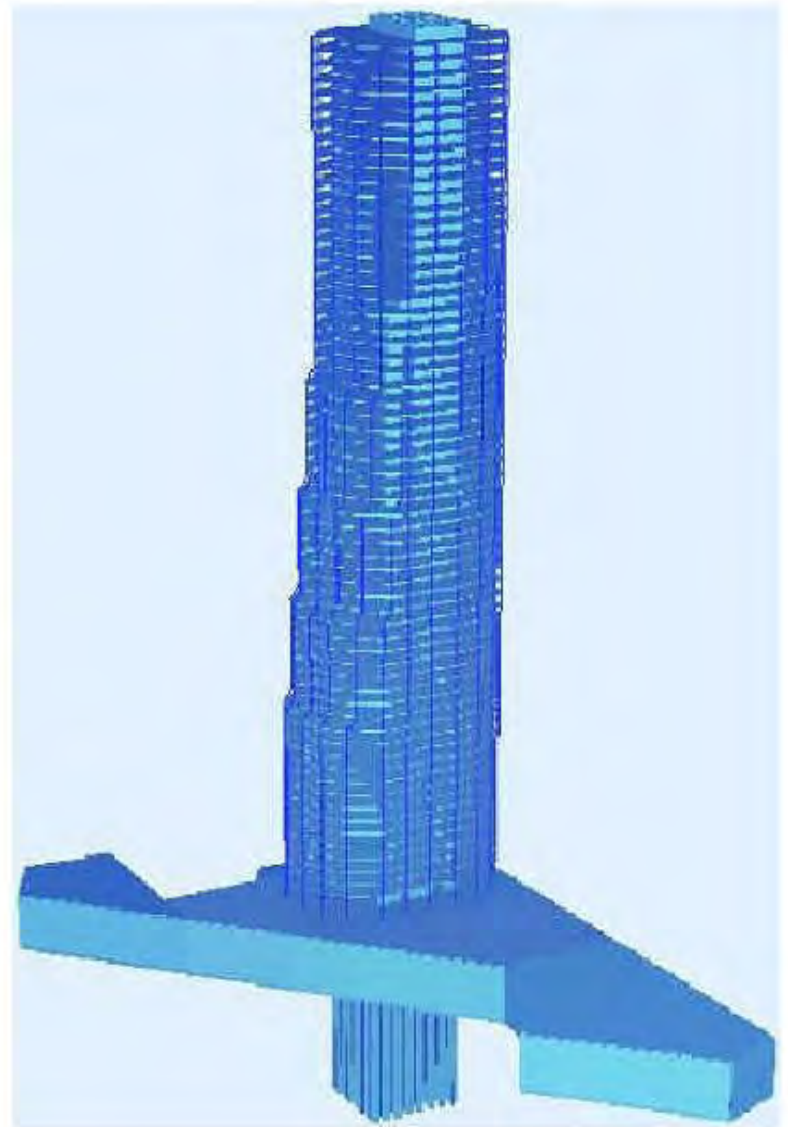

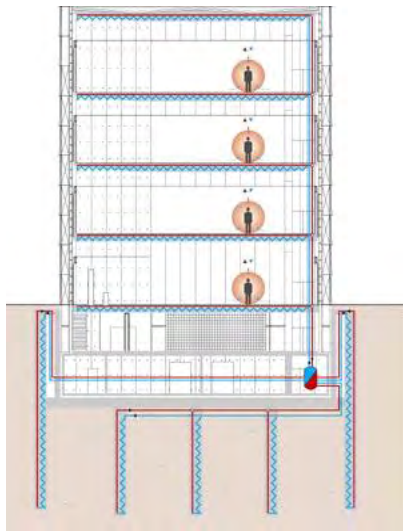



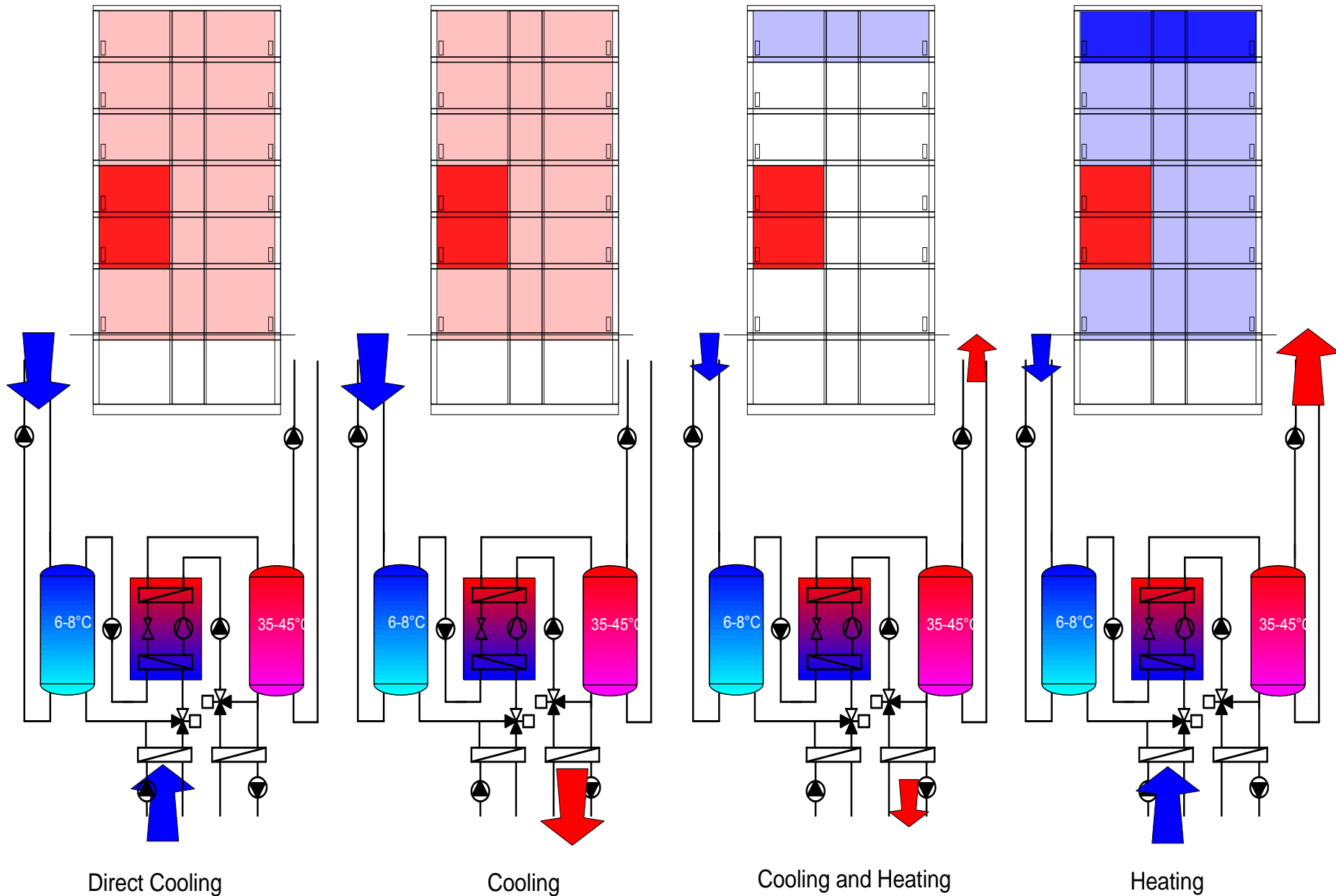

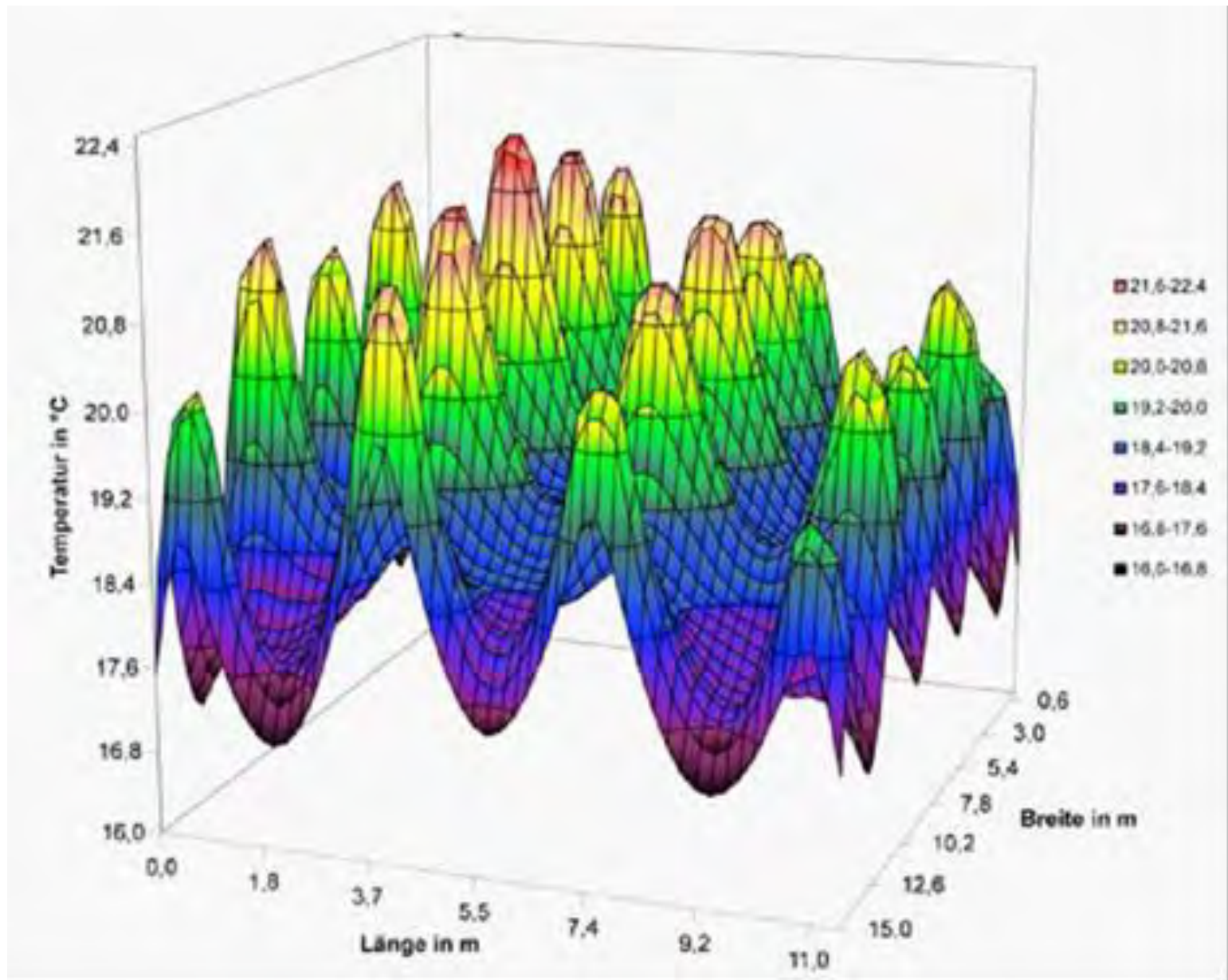

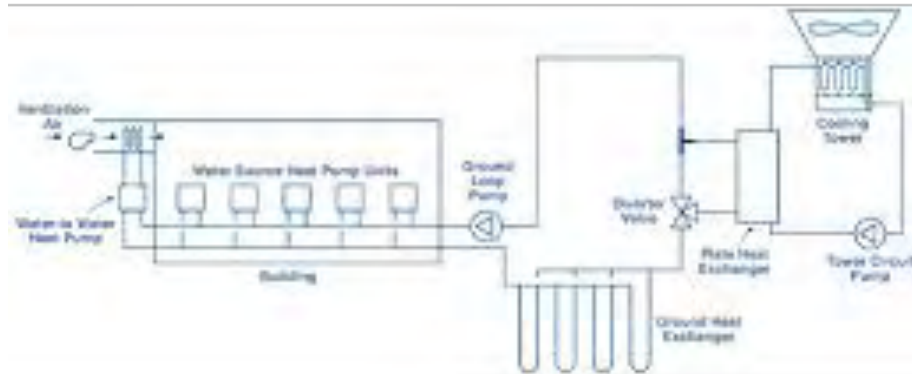
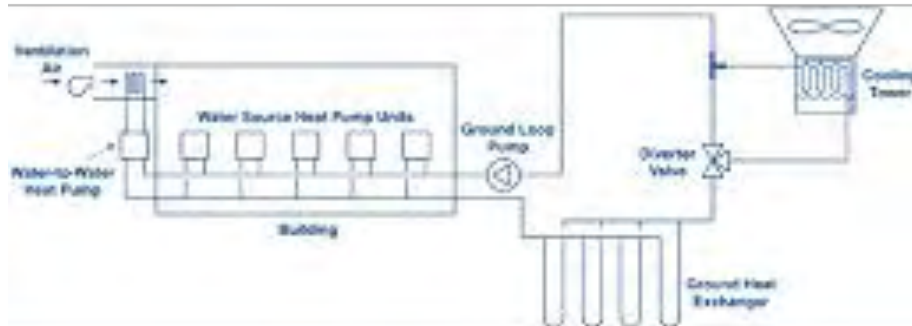

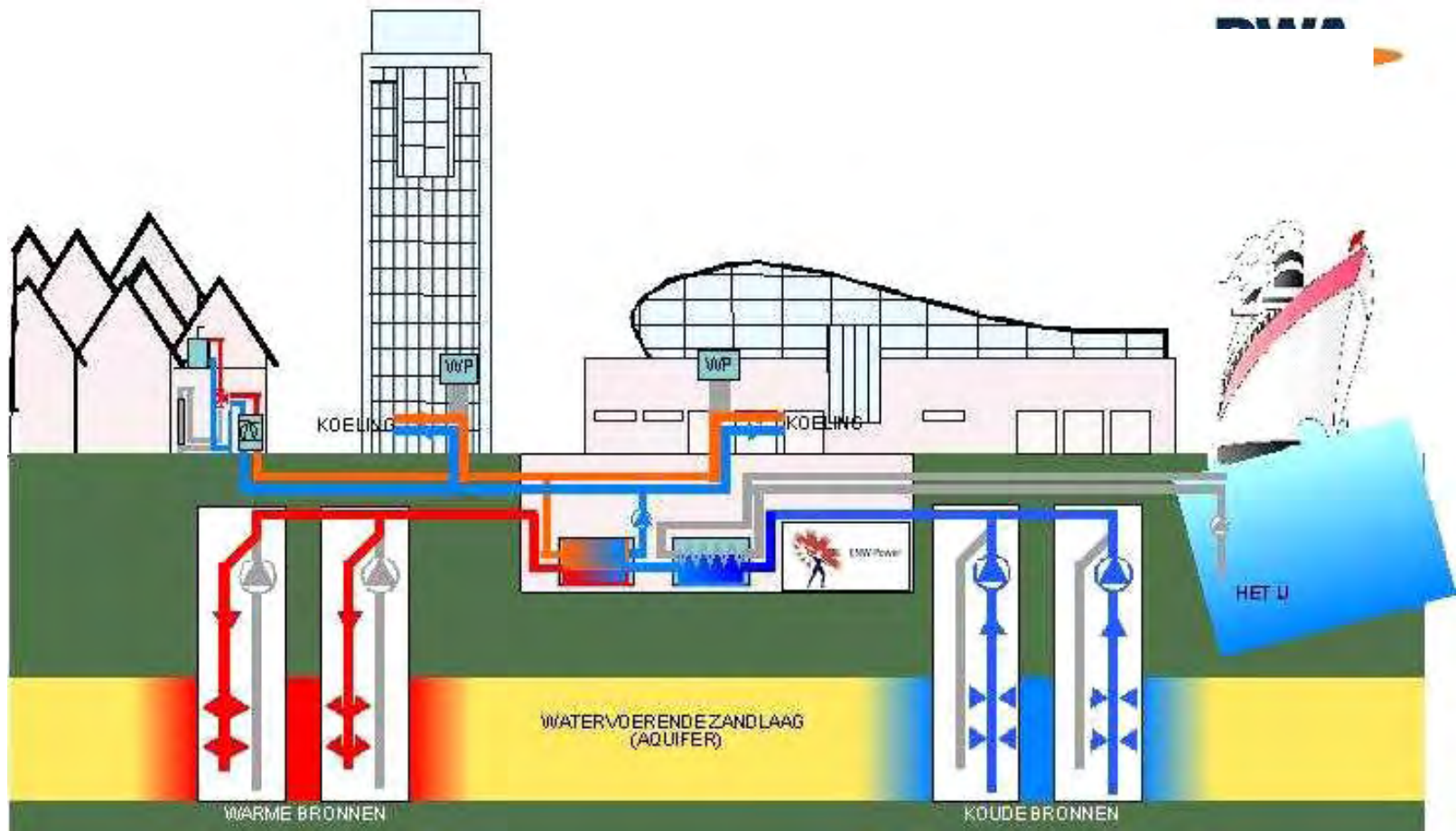

Low-Ex Systems

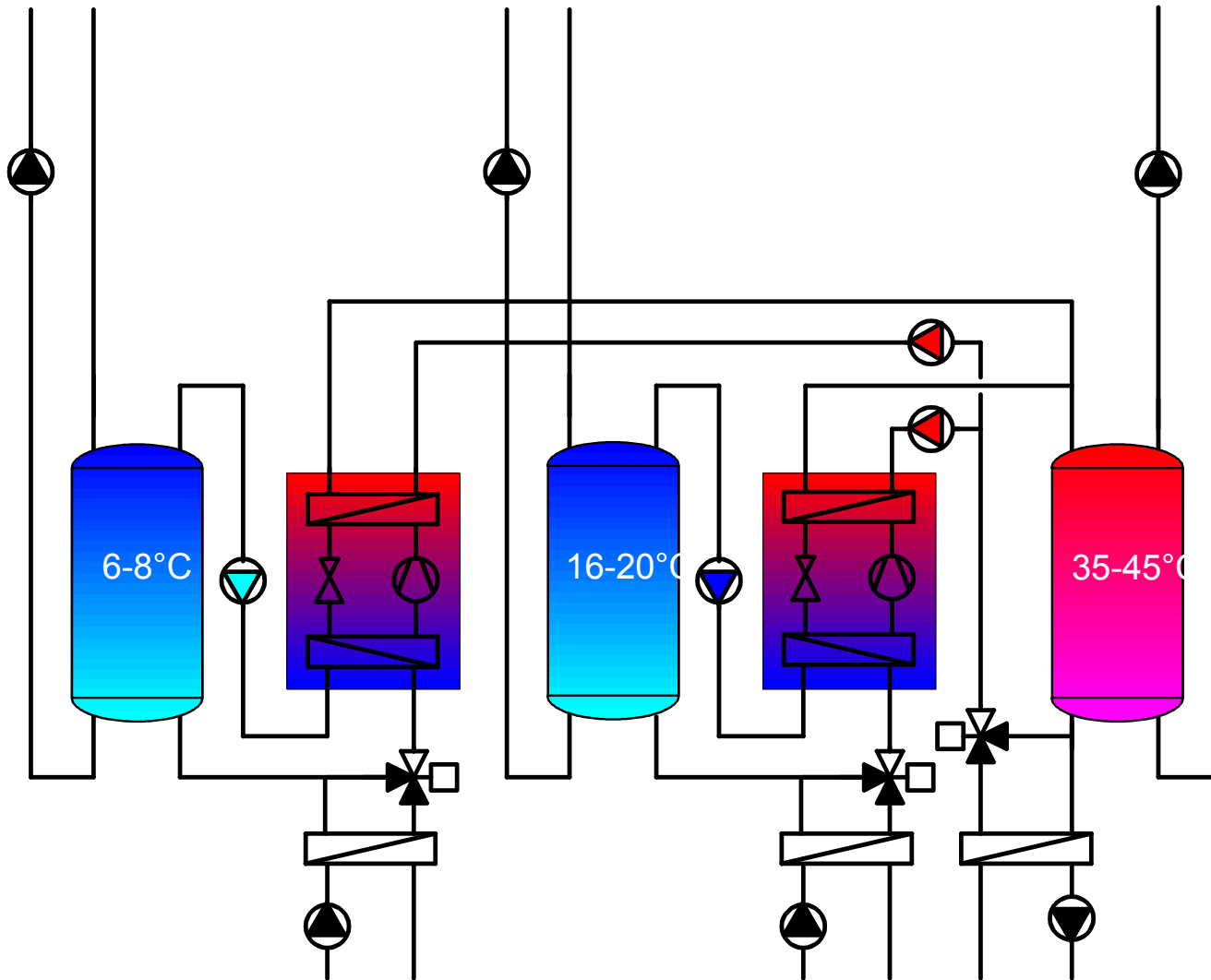



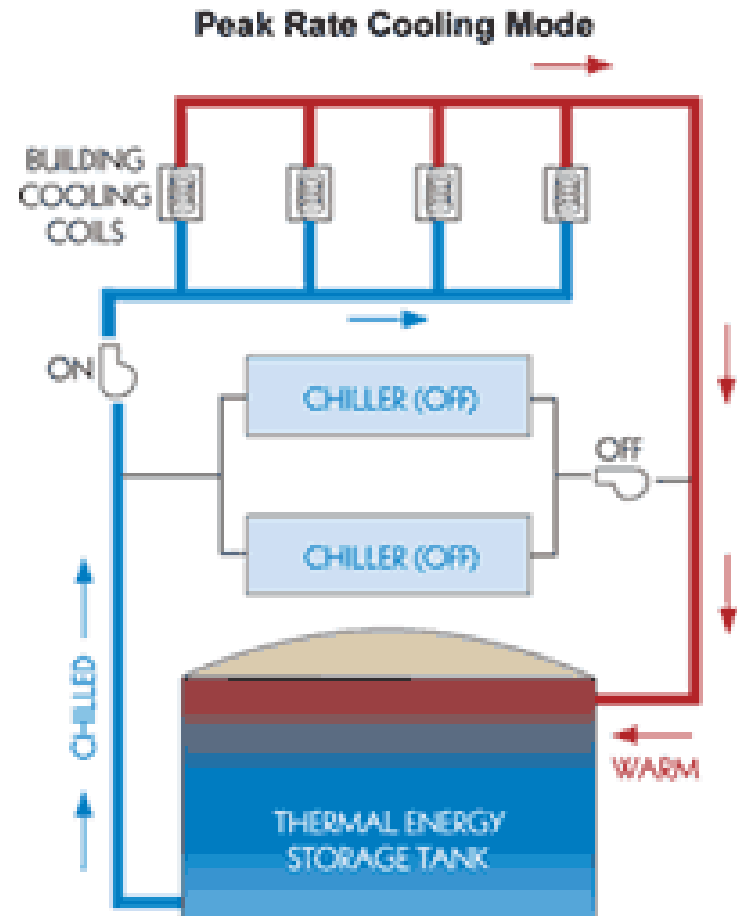
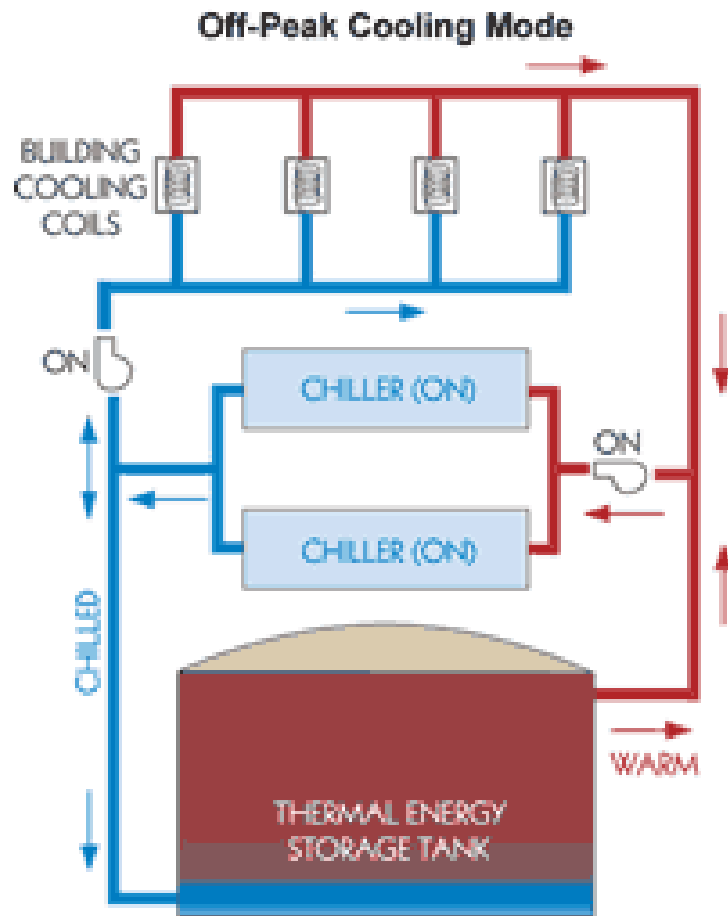

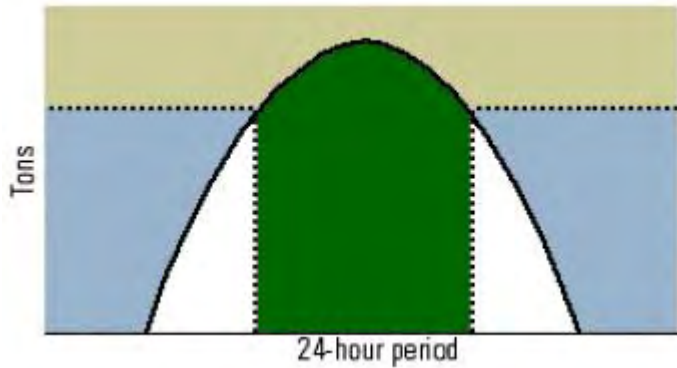

Full Storage

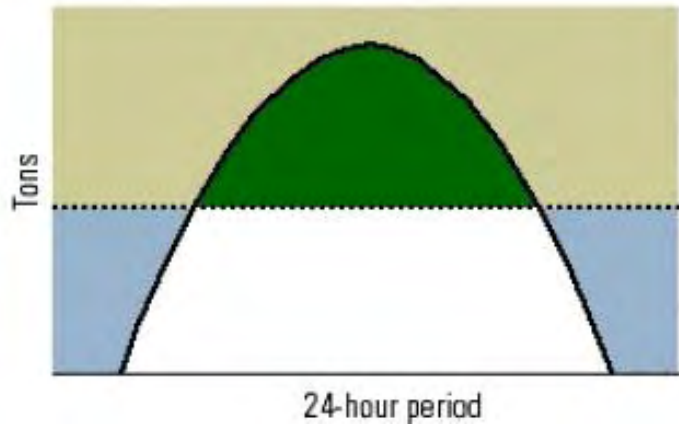
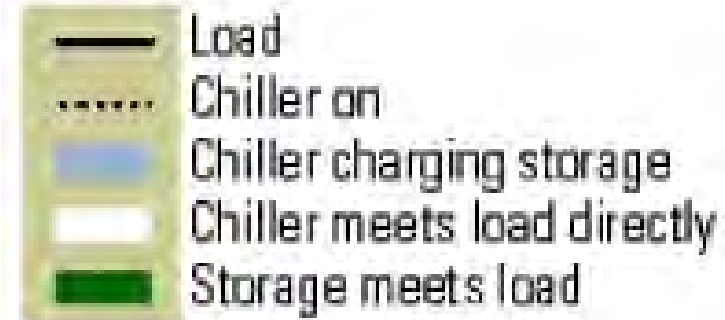

Partial Storage Load Levelling

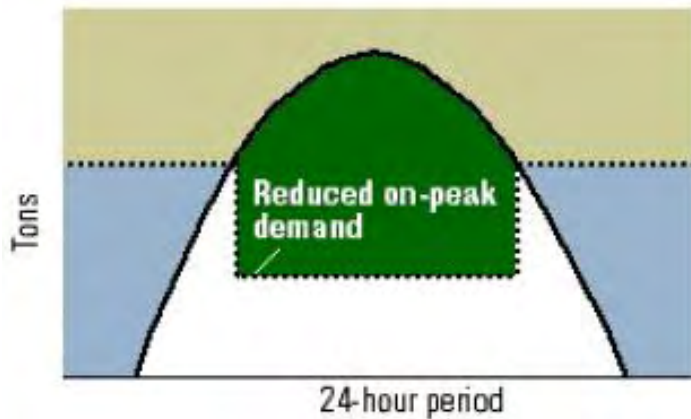

Partial Storage Demand Limiting

Conventional Office Building Using Chillers

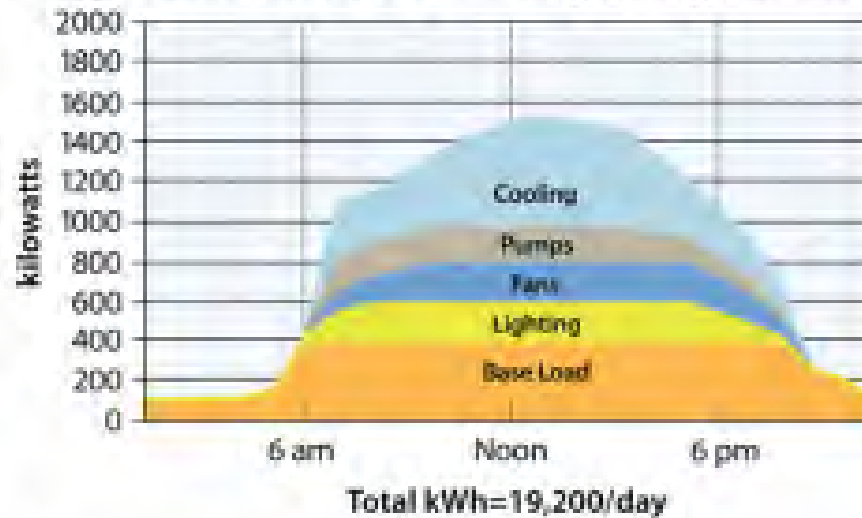

Thermal Energy Storage Electrical Profile

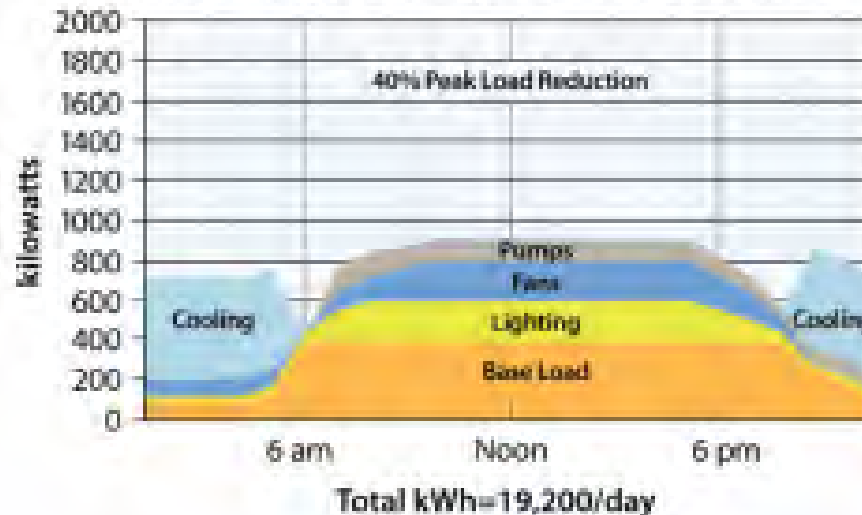

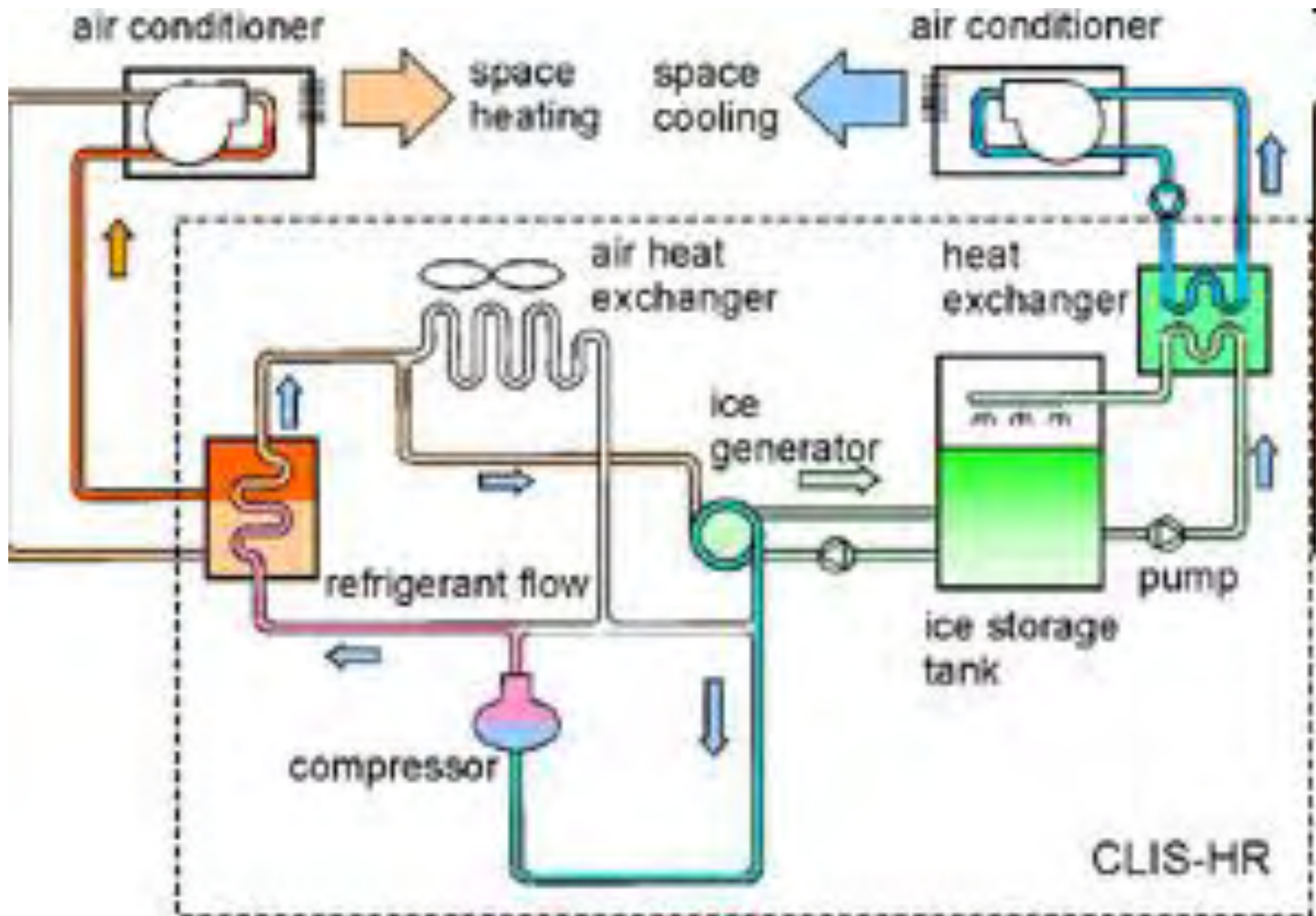

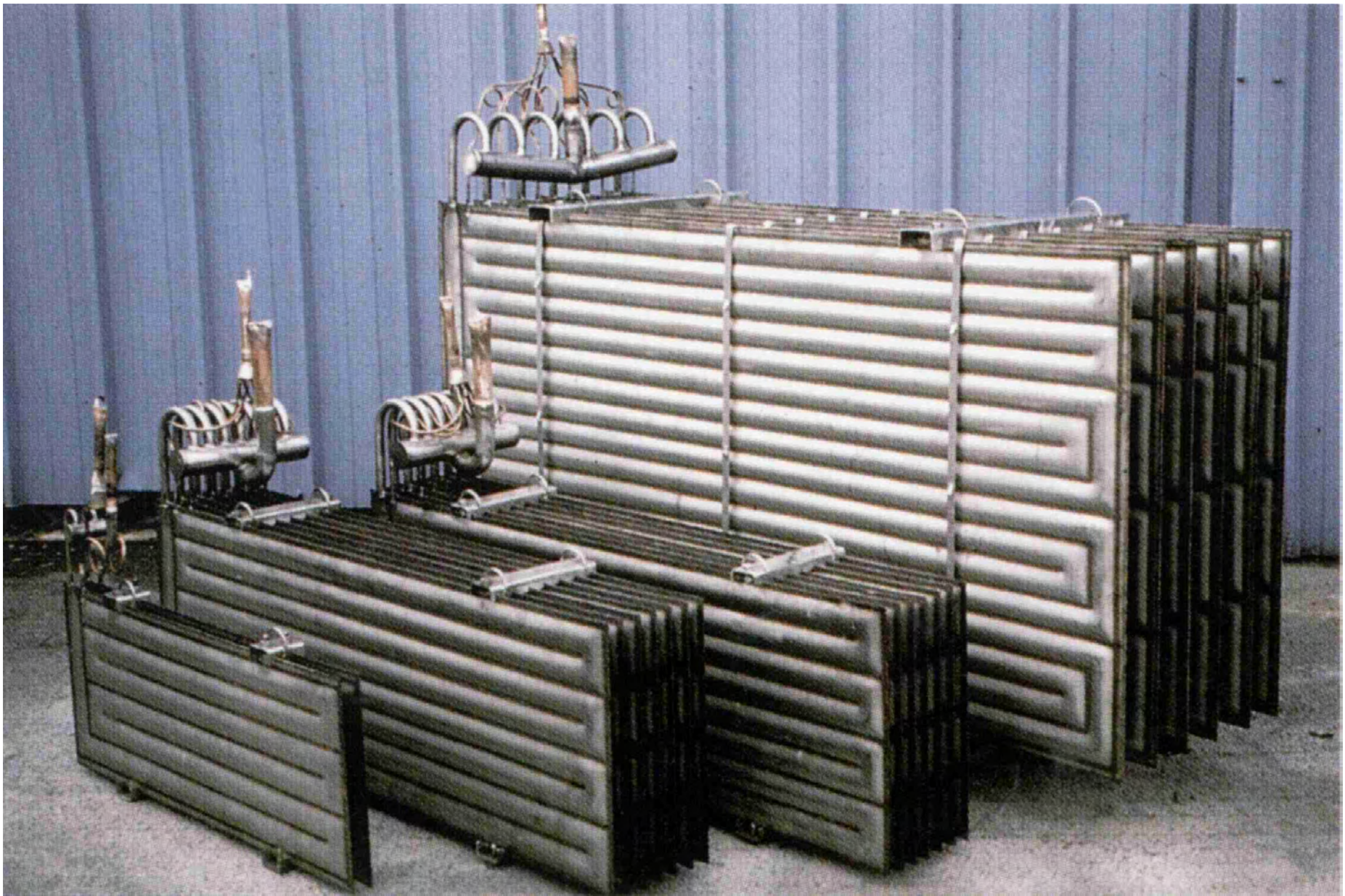



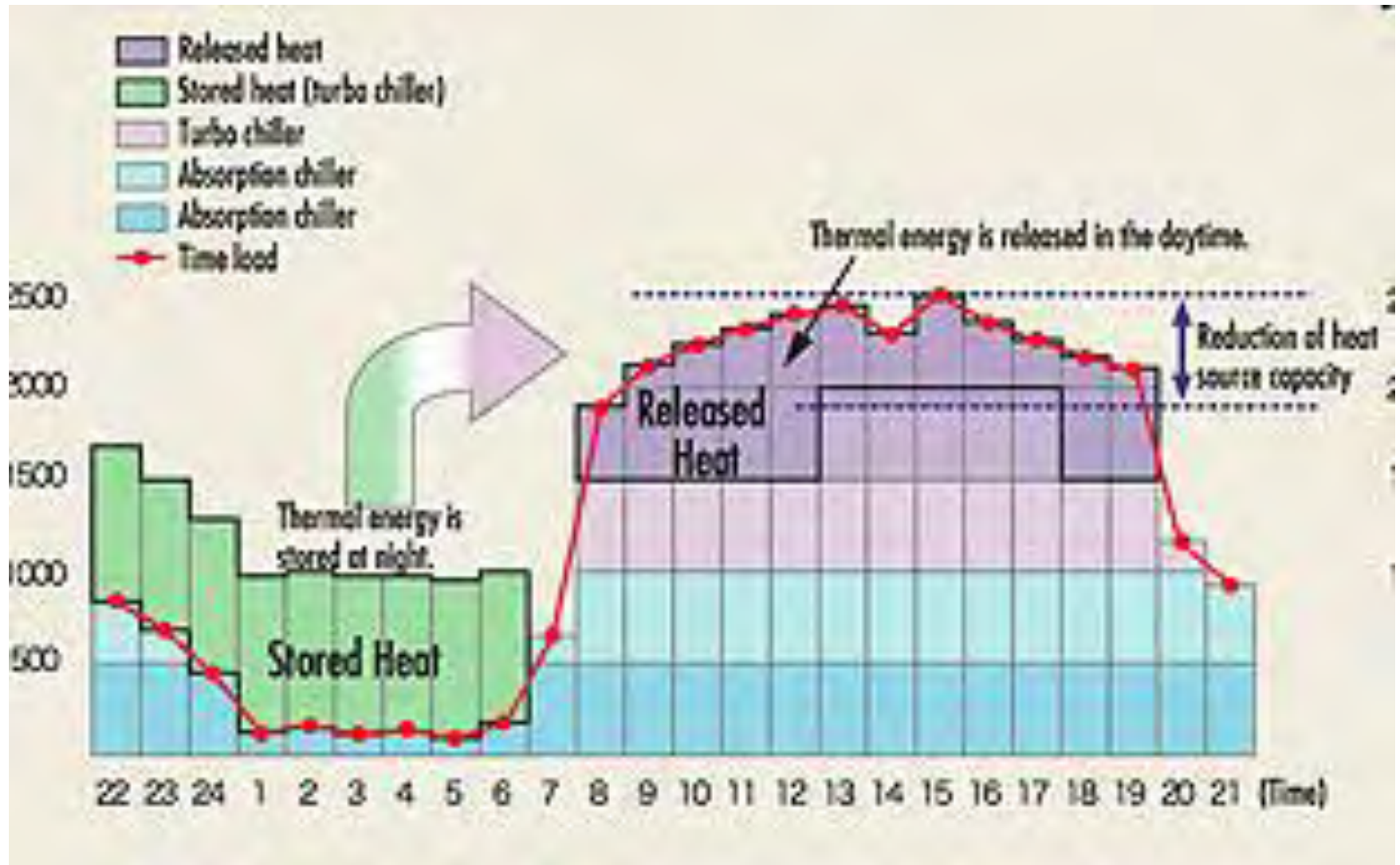

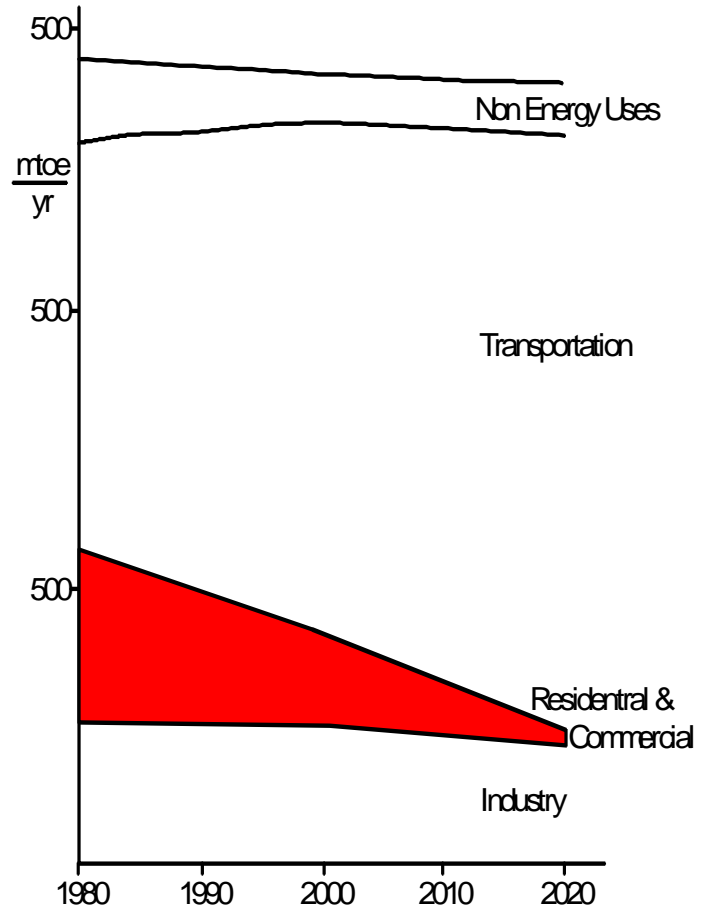
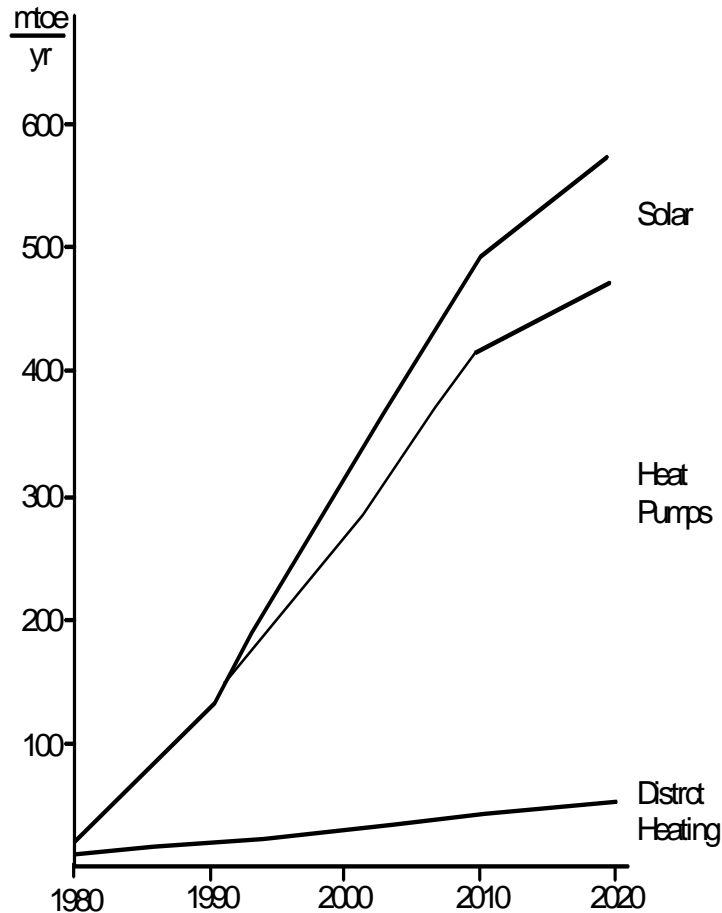

Strategy Study of the IEA 1980

Storage systems required

Building structure

Thermal energy stores at the condensor side (hot side)

- Sensible Stores

Thermal energy stores at the evaporator side (cold side)

- Sensible stores
- Latent heat stores

Electricity stores