

Workbook on Environmental Management Accounting

Metrics, Procedures and Principles

Ch. Jasch

Berichte aus Energie- und Umweltforschung

6b/2001

Impressum:

Eigentümer, Herausgeber und Medieninhaber:
Bundesministerium für Verkehr, Innovation und Technologie
Radetzkystraße 2, 1030 Wien

Verantwortung und Koordination:
Abteilung für Energie- und Umwelttechnologien
Leiter: DI Michael Paula

Liste sowie Bestellmöglichkeit aller Berichte dieser Reihe unter <http://www.nachhaltigwirtschaften.at>
oder unter:

Projektfabrik Waldhör
Nedergasse 23, 1190 Wien
Fax 01 /36 76 151 - 11
Email: projektfabrik@nextra.at

Workbook on Environmental Management Accounting Metrics, Procedures and Principles

**Univ.Doiz.Mag.Dr. Christine Jasch
Institute for environmental management and economics, Vienna**

**for the
UN division for sustainable development
Expert working group on
“Improving the Role of Government in the Promotion of
Environmental Managerial Accounting”**

**commissioned by
Austrian Federal Ministry of Transport, Innovation and Technology
Austrian Federal Ministry of Agriculture, Forestry, Environment and Water
Management
Austrian Federal Economic Chamber**

Vienna, February 2001

I want to thank the following persons and institutions for their comments and contributions:

Tarcisio Alvarez Rivero, UN DSD/DESA, New York, USA
Roger Burritt, Australian National University, Canberra, Australia
Ralph Chipman, UN DSD/DESA, New York, USA
Thomas Loew, IÖW Berlin, Germany
Richard Osborn, International Council for Local Environmental Initiatives, Hawker, Australia
Carsten Redmann, Markus Strobel, Stefan Enzler, Uta Müller, IMU Augsburg, Germany
Deborah Savage, Tellus Institute Boston, USA
Stefan Schaltegger, Tobias Hahn, University of Lüneburg, Germany
Ralph Thurm, Siemens AG, Munich, Germany
Bernd Wagner, University of Augsburg, Germany

and the other participants of the expert working group on “Improving the role of government in the Promotion of Environmental Management Accounting”.

TABLE OF CONTENT

Table of figures	5
1. Foreword	7
2. what is ema – environmental management accounting ?	11
2.1. Conventional monetary accounting	11
2.2. Physical accounting	12
2.3. Environmental management accounting	13
3. what are environmental costs ?	17
4. Annual corporate environmental expenditure	23
4.1. Waste and Emission treatment	24
4.1.1. Depreciation for related equipment	24
4.1.2. Maintenance and operating material and services	25
4.1.3. Related Personnel	25
4.1.4. Fees, Taxes, Charges	25
4.1.5. Fines and Penalties	25
4.1.6. Insurance for environmental liability	25
4.1.7. Provisions for clean up costs, remediation, etc.	26
4.2. Prevention and environmental management	28
4.2.1. External services for environmental management	28
4.2.2. Personnel for general environmental management activities	28
4.2.3. Research and Development	29
4.2.4. Extra expenditure for cleaner technologies	29
4.2.5. Other environmental management costs	30
4.3. Material purchase value	30
4.4. Processing costs	32
4.5. Environmental Revenues	32
4.5.1. Subsidies, Awards	33
4.5.2. Other earnings	33
5. system boundary – company fence	35
5.1. Environmental aspects in the balance sheet	35
5.2. Deriving expenditure from the profit and loss statement	39
5.3. Material flow balance on corporate level	42
5.3.1. Raw Materials	46
5.3.2. Auxiliary Materials	47
5.3.3. Packaging	47
5.3.4. Operating Materials	47
5.3.5. Merchandise	48
5.3.6. Energy	49
5.3.7. Water	49
5.3.8. Product	49
5.3.9. Waste	49
5.3.10. Waste Water	50
5.3.11. Air emissions	51
5.4. Organization of stock management and production planning	51
5.5. Consistency and Consolidation	56
5.5.1. Consistency	56
5.5.2. System boundaries	58
5.5.3. Consolidation	58
6. one step further down – process flow charts and cost accounting	65
6.1. Cost Accounting Basics	65
6.2. Process Flow Charts	69
6.3. Activity based costing	70
6.4. Flow Cost Accounting	75
6.4.1. What is the Purpose of Flow Cost Accounting?	75

6.4.2. The basic idea of flow cost accounting	77
6.4.3. The Method – an overview	79
7. application example - environmental performance indicators	83
7.1. Definitions of ISO 14031 – Standard on Environmental Performance Evaluation	83
7.2. General requirements for indicator systems	84
7.3. Generic indicator system	86
7.4. The problem of finding a meaningful denominator	87
7.4.1. Specific consumption/ Eco-intensity	90
7.4.2. Share percentage.....	90
7.4.3. Eco-efficiency Ratios.....	91
8. application example - calculating cost savings of environmental projects and investments	93
8.1. Capital Budgeting Basics.....	93
8.2. Budgeting for environmental protection	94
Future Regulation	95
Company Image	95
8.3. Calculation sheet for environmental investments and projects.....	96
9. outlook.....	100

ANNEX:

CHECKLISTS

- 1.1. Checklist for Air and Climate
- 1.2. Checklist for Waste Water
- 1.3. Checklist for Waste
- 1.4. Checklist for Soil and Ground Water
- 1.5. Checklist for Noise and Vibration
- 1.6. Checklist for Radiation
- 1.7. Checklist for other environmental costs
2. CONVERSION FACTORS
3. MATERIAL FLOW COST ACCOUNTING CHARTS
4. REFERENCES

Table of Figures

Figure 1: Terminology of financial accounting and cost accounting	12
Figure 2: System boundaries for material flow balances.....	13
Figure 3: EMA combines monetary and physical data	14
Figure 4: Past and future oriented EMA tools	15
Figure 5: What is EMA ?	16
Figure 6: Total corporate environmental costs	18
Figure 7: Material flows are money flows	18
Figure 8: Categorization of environmental accounting by material flow orientation	19
Figure 9: Overview on environmental cost roll over scheme.....	21
Figure 10: Different focus of environmental costs	22
Figure 11: Environmental expenditure/costs and revenue/earnings	23
Figure 12: Disposal Costs in Relation to Total Costs of Non-Product Output	30
Figure 13: Structure of the chart of accounts	35
Figure 14: Structure of the balance sheet	36
Figure 15: Cost-categories-oriented format.....	40
Figure 16: Cost-of-sales format.....	41
Figure 17: Material and Money Flows in a Paintshop	43
Figure 18: General Input/Output chart of accounts	44
Figure 19: Roll Over Scheme for Material flow balances	45
Figure 20: Differences between Material Purchase and Use for Production.....	53
Figure 21: Consistency Check with the Production Planning System.....	55
Figure 22: Data Sources for Environmental Expenditure/Cost Roll Over.....	57
Figure 23: Input Output framework for breweries.....	61
Figure 24: Process flow chart of breweries	62
Figure 25: Product life cycle assesement.....	63
Figure 26: Relationship between Cost Category, Cost Center and Cost Carrier Accounting .	67
Figure 27: Environmental Costs hidden in Overhead Accounts.....	68
Figure 28: Environmental Costs attributed to Cost Centers and Products.....	68
Figure 29: Process flow charts: Opening of the Black Box	69
Figure 30: Tracking and tracing of environmental related costs.....	70
Figure 31: Example of correct and incorrect cost allocation.....	71
Figure 32: Twofold allocation of environment related costs	72
Figure 33: Third allocation step	74
Figure 34: The company - seen as a material flow system	75
Figure 35: Typical proportion of costs in the manufacturing industry	76
Figure 36: The Basic Idea of Flow Cost Accounting	78
Figure 37: The components of flow cost accounting.....	80
Figure 38: Flow cost matrix (simplified).....	81
Figure 39: Environmental Performance Indicator System.....	86
Figure 40: Environmental performance indicator matrix.....	88
Figure 41: Share of environmental costs.....	91
Figure 42: Calculation sheet for environmental investments and projects	98

1. FOREWORD

The objective of this paper is to define principles and procedures for Environmental Management Accounting (EMA), with a focus on techniques for quantifying environmental expenditures or costs, as a basis for the development of national EMA guidelines and frameworks. The intended users of these EMA metrics are national governments interested in establishing national EMA guidelines appropriate to their own countries' context and organizations seeking to install EMA systems for better controlling and benchmarking purposes.

The limits of traditional financial and cost accounting methods to reflect organizations' efforts towards sustainability and to provide management with information needed to make sustainable business decisions have broadly been recognized. Information on environmental performance of organizations might be available to some extent, but, company internal as well as in public authorities, decision-makers are seldom able to link environmental information to economic variables and are crucially lacking environmental cost information.

As a consequence, decision-makers fail to recognize economic value of natural resources as assets, and the business and financial value of good environmental performance. Beyond 'good-will' initiatives, few market-based incentives exist to integrate environmental concerns in decision making. Therefore, there is a need to upgrade the business decision-making process by including information on material flows and related costs to account for efforts towards sustainable development.

Although differing definitions and applications exist, the general use of EMA information is for internal organizational calculation and decision-making. EMA metrics for internal decision-making include both: physical metrics for material and energy consumption, flows, and final disposal, and monetarised metrics for costs, savings, and revenues related to activities with a potential environmental impact. The metrics most useful for decision-making depend on the type of organization (e.g. manufacturing vs. service sector) and the types of decisions to be made (e.g., purchasing decisions about raw materials; investment decisions for energy efficiency; altered product design).

EMA data support environmental management systems and decision making with regard to improvement targets and investment options. Linked financial and environmental performance indicators are important for controlling and benchmarking purposes. The material flow balance as well as the derived indicators are vital information for environmental reporting. Ranking agencies are interested to see combined monetary and physical approaches towards sustainability.

The costs for industry of environmental protection, including pollution reduction, waste management, monitoring, regulatory reporting, legal fees and insurance, have increased rapidly in the past 20 years with increasingly stringent environmental regulations. Conventional management accounting systems attribute many of those environmental costs to general overhead accounts, with the consequence that product and production managers have no incentive to reduce environmental costs and executives are often unaware of the extent of environmental costs.

In conventional cost accounting, the aggregation of environmental and non-environmental costs in overhead accounts results in their being "hidden" from management. There is substantial evidence that management tends to underestimate the extent and growth of such costs. By identifying, assessing and allocating environmental costs, EMA allows management to identify opportunities for cost savings. Prime examples from the EMA literature are the savings that can result from replacement of toxic organic solvents by non-toxic substitutes, thus eliminating the high and growing costs of regulatory reporting, hazardous waste handling and other costs associated with the use of toxic materials. Many other examples deal with more efficient material use, highlighting the fact that waste is expensive not because of

disposal fees, but because of the wasted material purchase value. Waste and emissions are therefor a sign of inefficient production.

The definition of the “environmental” part of these costs is often troublesome. As well for cleaner technologies, which are often more efficient in many aspects and prevent the emissions at source, as for many other costs, which often include increased efficiency or health and safety aspects, the “environmental” part can hardly be separated. To the extreme, on can say, that if a solution is 100 % for the “environment”, it often is actually not, because then it will most likely be an end-of-the-pipe treatment, which doesn’t solve the problem at source, but shifts it to another environmental media (e.g. form air to soil and then to water). These approaches are costly and not efficient.

The approach presented in this paper has the underlying assumption, that all purchased materials must by physical necessity leave the company either as product or waste and emission. Waste is thus a sign of inefficient production. Therefor when calculating environmental costs, not only disposal fees are regarded, but the wasted material purchase value and the production costs of waste and emissions are added.

A rule of thumb of environmental management is that 20 per cent of production activities are responsible for 80 per cent of environmental costs. When environmental costs are allocated to overhead accounts shared by all product lines, products with low environmental costs subsidize those with high costs. This results in incorrect product pricing which reduces profitability.

A relatively simple application of EMA that may yield large cost savings is to waste management, as the costs of handling and disposing of waste are relatively easy to define and to allocate to specific products. Other environmental costs, including costs of regulatory compliance, legal costs, damage to the corporate image, and environmental liabilities and risks, are more difficult to assess. But, the largest part of all environmental costs lies in the material purchase value of non-product output and can come up to 10 to 100 times the costs of disposal, depending on the business sector.

Financial accounts include most of these costs, but aggregated in a way that does not identify the specifically environmental costs. There is evidence, however, that some environmental liabilities and risks that are in principle covered by reporting requirements are often not reported, for example liabilities for cleaning up contaminated land. A comprehensive EMA system would promote more complete financial accounts in such cases.

Still, future costs and less tangible costs are hardly found in the existing accounting records. The expected future costs for a necessary wastewater treatment plant upgrade should be part of the current budgeting cycle. Less tangible costs like potential future liability claims and company image costs from poor environmental performance should be considered when comparing investment options.

This paper is based on research and pilot projects on environmental cost and performance metrics mostly in the German-speaking countries, but also from Australia, Canada, Japan and the USA. In order to design the most broadly useful EMA metrics framework possible, it reviews not only metrics specifically for EMA and internal-decision making, but also for external performance reporting and disclosure.

The key goal of this paper is to outline a set of core EMA metrics of potential value to any type of corporation, business firms in all sectors, including services as well as municipalities. Still, the more material flows and environmental risks within an organization, the higher the potential value of an environmental management accounting system.

Adding the purchase value of non-material output (waste, waste water) to the environmental costs, makes the share of “environmental “ costs higher in relation to other costs. However, it is not the goal of this paper to show, that environmental protection is expensive. It is also not the most important task to spent a lot of time defining exactly which costs are environmental or which costs are not, or what percentage of something is environmental or not.

The most important task is to make sure that all relevant, significant costs are considered when making business decisions. In other words, “environmental” costs are just a subset of the bigger cost universe that is necessary for good decision making. “Environmental” costs are part of an integrated system of material and money flows throughout a corporation, and not a separate type of cost altogether. Doing environmental management accounting is simply doing better, more comprehensive management accounting, while wearing an “environmental” hat, that opens the eyes for hidden costs. Therefor, the focus of material flow accounting is no longer assessing the total “environmental” costs, but on a revised calculation of production costs on the basis of material flows.

The paper is written from the perspective of accountants, allowing them to derive environmental expenditures and costs from existing company data with the help of the environmental and production manager. The quantitative physical measures are based on material flows or the so-called operational system in ISO 14031, linking them with the financial list of balances.

The paper includes checklists for each environmental medium and for calculation of investments, making this a helpful tool for accountants, controllers and environmental managers, and facilitating international standardization.

The workbook on EMA metrics has the following structure:

- Chapter 2 explains the term EMA Environmental Management Accounting, its fields of application and linkages to other information systems.
- Chapter 3 discusses the term and range of environmental costs.
- Chapter 4 explains the roll over scheme for annual corporate environmental expenditures, which comprises the transition of the environmental part of the data from financial accounting and cost calculation.
- Chapter 5 deals with information available on the company level, traces environmental aspects in the balance sheet and where to find them in the profit and loss accounts. It explains the structure of material flow balances and where to get the necessary data from stock management and production planning systems. The last issues dealt with are consistency and consolidation of data.
- Chapter 6 goes one step further down into the organization and highlights the principles and terminology of cost accounting, process flow charts, overhead cost roll over, activity based costing and flow cost accounting.
- Chapter 7 describes environmental performance indicators as an application example of EMA. The chapter is based on the outline of ISO 14031, the world wide standard on environmental performance evaluation, and specifically addresses the problem of finding meaningful denominators for indicators.
- Chapter 8 describes another important application field, using EMA data for the calculation of investment decisions and cost savings.

The annex provides checklists for environmental expenditures and earnings by environmental media and conversion factors for the material flow balance. A list of references allows more detailed study of the subject.

2. WHAT IS EMA – ENVIRONMENTAL MANAGEMENT ACCOUNTING ?

Accounting is done in monetary and physical units.

2.1. Conventional monetary accounting

Conventional corporate monetary accounting comprises

- Financial accounting (bookkeeping, balancing, consolidation, auditing of the financial statement and reporting)
- Cost accounting (also called management accounting)
- Corporate statistics and indicators (past oriented)
- Budgeting (future oriented)
- Investment appraisal (future oriented)

Book keeping and cost accounting provide the data basis for the other instruments. They can and have also been used to trace expenditures, costs, indicators, investments and saving, due to measures for environmental protection, but not systematically. Corporate application of financial accounting comprises mainly internal calculation tools, but is also used for external reporting to financial authorities, shareholders and the company register. Statistical agencies make use of this information, but this national application is beyond the scope of financial accounting.

Cost accounting constitutes the central tool for internal management decisions such as product pricing and is not regulated by law. This internal information system deals with the following questions: What are the production costs for different products and what should be the selling price of these products? The main stakeholders in cost accounting are members of different management item (e.g. executive, site, product and production managers). For environmental management, the related costs (mostly hidden in general overhead costs) may be traced and allocated to products and cost centers. The appropriate approach will therefore be described in Chapter 6.

Cost accounting is based on data obtained from financial accounting but sometimes uses different values, e.g. repurchasing values for depreciations, average prices for material input or imputed interest. The latter are assessed differently due to the system of **roll-over from expenditure to costs**. Most small and medium sized companies, SMEs, use the same figures with only minor adjustments.

Alas, many companies do not have a separate cost accounting system, but calculate on the basis of the financial accounting data from bookkeeping instead. **Financial accounting**, on the contrary, is mainly designed to satisfy the information needs of external shareholders and financial authorities, both of whom have a strong economic interest in standardized comparable data and in receiving true and fair information about the actual economic performance of the company. Therefore, financial accounting and reporting are being dealt with in national laws and international accounting standards. They regulate how specific items should be treated, specifying, e.g., whether environmental investments should be capitalized or expensed, under which circumstances provisions may be made for future treatment liabilities, or when contingent liabilities should be disclosed.

Imputed (calculatory) approaches as used in cost accounting are not permissible. All costs must therefore be recalculated to show actual expenditure and prices.

Terminology

Financial accounting deals with revenues and expenditures as shown in the profit and loss account, and with assets and liabilities as listed in the balance sheet. More detailed information is available from the list of balances. In cost accounting, the terms dealt with are costs and earnings; there is no equivalent to the balance sheet.

Requiring a somewhat different assessment method, the various expenditure items in financial accounting correspond to the categories of costs which are allocated to the respective cost centers (in-house production processes) and cost carriers/objects (products).

Financial Accounting	Cost Accounting
Balance sheet	
Assets	No equivalent
Liabilities	No equivalent
Profit and loss account	Cost roll over
Expenditure	Cost
Expenditure items	Cost categories
Revenue	Earnings
	Cost calculation
No equivalent	Cost centers
Calculation of production expenditure	Cost carriers/objects (Products)

Figure 1: Terminology of financial accounting and cost accounting

Costs or expenditures?

The assessment can be based on expenditures from the profit and loss account or on internal cost accounting documents, depending on the structure of internal information systems. It is the task of the company's controller to define the most appropriate data base once the general outline of the approach to be adopted has been defined.

Since environmental cost assessment should also be used for uniform reporting procedures, and given that a calculatory approach in stating environmental expenditure in the profit-loss account is not permitted, the workbook recommends to refer to the actual expenditure quoted in financial accounting but to allocate it to sites, cost centers and products.

System boundaries of financial and cost accounting

Data determination for the two accounting methods differs. For financial accounting, the system boundary is the legal entity and therefor mostly the company fence, sometimes, aggregating over several production sites. Cost accounting steps further down, inside the company and traces the costs of production steps and products.

2.2. Physical accounting

The same structure applies to physical accounting. The core part of environmental information systems are material flow balances in physical units of material, water and energy flows within a defined system boundary. This can be on the corporate level, but also one step further done

to cost centers and production processes or even down to machinery's and products. Then, it becomes the task of process technicians and not so much accountants to tackle and trace the necessary data.

INPUT		System boundaries		OUTPUT
		Nations		
Materials	⇒	Regions	⇒	Products
Energy	⇒	Corporations	⇒	Waste
Water	⇒	Processes	⇒	Emissions
		Products		

Figure 2: System boundaries for material flow balances

On a higher level, material flow balances are calculated for regions and countries, referred to under the term “national resource accounting”. Austria, Germany and Japan are the first countries that have consistent material flow balances for their nations, which are provided by the statistical agencies.

On a national level, statistical agencies and economic sciences also strive to estimate total annual environmental costs of industry and the costs to the general public due to environmental pollution (so called external costs, as they are not born by the polluting company, but the general public). External costs are part of environmental accounting as well as national resource accounting in material flows, but both are not management accounting.

2.3. Environmental management accounting

The main problem of environmental management accounting is that we lack a standard definition of environmental costs. Depending on various interests, they include a variety of costs, e.g. disposal costs or investment costs and, sometimes, also external costs (i.e. costs incurred outside the company, mostly to the general public). Of course, this is also true for profits of corporate environmental activities (environmental cost savings). In addition, most of these costs are usually not traced systematically and attributed to the responsible processes and products, but simply summed up in general overhead.

The fact that environmental costs are not fully recorded often leads to distorted calculations for improvement options. Environment protection projects, aiming to prevent emissions and waste at the source (avoidance option) by better utilizing raw and auxiliary materials and requiring less (harmful) operating materials are not recognized and implemented. The economic and ecological advantages to be derived from such measures are not used. The people in charge are often not aware that producing waste and emissions is usually more expensive than disposing of them.

Experience shows that the environmental manager barely has access to the actual cost accounting documents of the company and only is aware of a tiny fraction of aggregate environmental costs. On the other hand, the controller does have most of the information but is unable to separate the environmental part without further guidance. In addition, he or she is limited to thinking within the framework of existing accounts. Also, the two departments tend to have a severe language problem.

Calculated or real costs?

Companies are interested in their actual costs. Costs incurred elsewhere are of little interest for corporate decision making. Therefore, the focus of this paper is on actual company costs rather than on externalities and estimated future price changes. It is the task of governments, not of accountants, to ensure that prices reflect the real costs to the society.

All expenditure should refer to the same reporting period and be derived from the annual list of balances, which in the first round means a yearly monitoring of total annual environmental expenditure. This does not include external costs and envisaged future price changes, and the environmental roll over scheme is not used for the calculation of investment options or project costs and cost savings. Chapter 8 deals with these issues separately.

Environmental management accounting thus represents a combined approach which provides for the transition of data from financial accounting and cost accounting to increase material efficiency, reduce environmental impact and risk and reduce costs of environmental protection. For the following text, the term expenditure is always used where a precise distinction to implicit cost approaches is necessary. Otherwise, the term cost is used. For the different cost categories of the environmental roll over scheme (figure 8), guidance is given on where to find them and how to deal with them when expenditures or costs are assessed.

Environmental management accounting, EMA, is performed by private or public corporations, but not nations and has a monetary as well as physical component.

ACCOUNTING IN MONETARY UNITS		ACCOUNTING IN PHYSICAL UNITS	
CONVENTIONAL ACCOUNTING	ENVIRONMENTAL MANAGEMENT ACCOUNTING		OTHER ASSESSMENT TOOLS
	MEMA MONETARY EMA	PEMA PHYSICAL EMA	

Figure 3: EMA combines monetary and physical data

Application fields for the use of EMA data are

- Assessment of annual environmental costs/expenditure
- Product pricing
- Budgeting
- Investment appraisal, calculating investment options
- Calculating costs, savings and benefits of environmental projects
- Design and implementation of environmental management systems
- Environmental performance evaluation, indicators and benchmarking
- Setting quantified performance targets
- Cleaner production, pollution prevention, supply chain management and design for environment projects
- External disclosure of environmental expenditures, investments and liabilities
- External environmental or sustainability reporting
- Other reporting of environmental data to statistical agencies and local authorities

EMA data and their application can be structured into past and future oriented tools.

EMA Environmental Management Accounting			
MEMA Monetary EMA		PEMA Physical EMA	
Past oriented tools	Future oriented tools	Past oriented tools	Future oriented tools
Annual environmental expenditure or costs, roll over from book keeping and cost accounting	Monetary environmental budgeting and investment appraisal	Material, energy and water flow balances	Physical environmental budgeting and investment appraisal
	Calculating costs, savings and benefits of projects	Environmental performance evaluation and indicators, benchmarking	Setting quantified performance targets
External disclosure of environmental expenditures, investments and liabilities		External environmental reporting Other reporting to agencies and authorities	Design and implementation of environmental management systems, cleaner production, pollution prevention, design for environment, supply chain management, etc.

Figure 4: Past and future oriented EMA tools

(Source: adopted from Schaltegger St., Hahn T., Burrit R., 2000)

EMA has been defined in the 2nd and 3rd meeting of the expert working group on “Improving the role of government in the promotion of EMA” of the UN Division for Sustainable Development to cover the issues in the two middle columns of the table. This paper focuses on the bold internal part of EMA of Figure 5 with data on company, process and product level for business application.

ACCOUNTING IN MONETARY UNITS		ACCOUNTING IN PHYSICAL UNITS	
CONVENTIONAL ACCOUNTING	ENVIRONMENTAL MANAGEMENT ACCOUNTING		OTHER ASSESSMENT TOOLS
	MEMA MONETARY EMA	PEMA PHYSICAL EMA	
DATA ON CORPORATE LEVEL			
CONVENTIONAL BOOK KEEPING	ROLL OVER OF ENVIRONMENTAL PART FROM BOOK KEEPING AND COST ACCOUNTING	MATERIAL FLOW BALANCES ON CORPORATE LEVEL FOR MASS, ENERGY AND WATER FLOWS	PRODUCTION PLANNING SYSTEMS, STOCK ACCOUNTING SYSTEMS
DATA ON PROCESS/COST CENTER AND PRODUCT/COST CARRIER LEVEL			
COST ACCOUNTING	ACTIVITY BASED MATERIAL FLOW COST ACCOUNTING	MATERIAL FLOW BALANCES ON PROCESS AND PRODUCT LEVEL	OTHER ENVIRONMENTAL ASSESSMENTS, MEASURES AND EVALUATION TOOLS
BUSINESS APPLICATION			
INTERNAL USE FOR STATISTICS, INDICATORS, CALCULATING SAVINGS, BUDGETING AND INVESTMENT APPRAISAL	INTERNAL USE FOR STATISTICS, INDICATORS, CALCULATING SAVINGS, BUDGETING AND INVESTMENT APPRAISAL OF ENVIRONMENTAL COSTS	INTERNAL USE FOR ENVIRONMENTAL MANAGEMENT SYSTEMS AND PERFORMANCE EVALUATION, BENCHMARKING	OTHER INTERNAL USE FOR CLEANER PRODUCTION PROJECTS AND ECODESIGN
EXTERNAL FINANCIAL REPORTING	EXTERNAL DISCLOSURE OF ENVIRONMENTAL EXPENDITURES, INVESTMENTS AND LIABILITIES	EXTERNAL REPORTING (EMAS-STATEMENT, CORPORATE ENVIRONMENTAL REPORT, SUSTAINABILITY REPORT)	OTHER EXTERNAL REPORTING TO STATISTICAL AGENCIES, LOCAL GOVERNMENTS ETC.
NATIONAL APPLICATION			
NATIONAL INCOME ACCOUNTING BY STATISTICAL AGENCY	NATIONAL ACCOUNTING ON INVESTMENTS AND ANNUAL ENVIRONMENTAL COSTS OF INDUSTRY, EXTERNALITIES COSTING	NATIONAL RESSOURCE ACCOUNTING (MATERIAL FLOW BALANCES FOR COUNTRIES, REGIONS AND SECTORS)	

Figure 5: What is EMA ?

3. WHAT ARE ENVIRONMENTAL COSTS ?

From a macroeconomic perspective, the prices for scarce raw materials, pollution and disposal do not reflect their true value and cost to society. Health hazards, repairs of contaminated sites etc. are environmental costs usually not borne by the polluter but by the general public.

Environmental costs comprise both internal and external costs and relate to all costs occurred in relation with environmental damage and protection. **Environmental protection costs** include costs for prevention, disposal, planning, control, shifting actions and damage repair that can occur at companies, governments or people (VDI 2000¹). This book only deals with corporate environmental costs. External costs which result from corporate activities but are not internalized via regulations and prices are not considered. It is the role of governments to apply political instruments such as eco-taxes and emission control regulations in order to enforce the 'polluter-pays' principle and thus to integrate external costs into corporate calculations.

What then are corporate environmental costs? Costs incurred to deal with contaminated sites, effluent control technologies and waste disposal may first come to mind.

Measures for environmental protection comprise all activities taken for legal compliance, compliance with own commitments or voluntarily. Economic effects are no criteria, but the effect on prevention or reduction of environmental impact. (VDI 2000).

Corporate environmental protection expenditure includes all expenditure for measures for environmental protection of a company or on its behalf to prevent, reduce, control and document environmental aspects, impacts and hazards, as well as disposal, treatment, sanitation and clean up expenditure. The amount of corporate environmental protection expenditure is not directly related to the environmental performance of a company (VDI 2000).

Waste and emission treatment using end-of-pipe technologies is usually the first step on the environmental protection path. End-of-pipe investments are gradually implemented as the need for legal compliance increases. Policy debates focus on the internalization of external costs by raising prices for scarce raw materials, water and emissions, and some companies actually try to predict these price changes in their calculations. Public as well as corporate activities aimed at environmental management are still focusing on end-of-pipe technologies, which may in the short run appear to be a fast solution, but in the long run often actually amount to more consumption of material and energy, more capital expenditure and more work hours than if measures are taken at the source.

The principle of pollution prevention does not only address the question of waste disposal, but also examines where the waste comes from and how can it be prevented. Pollution prevention can be achieved by two factors, namely by changes in product design or production processes and by better housekeeping assisted by environmental management systems, with the two factors often being interlinked. Integrated environmental protection attempts to avoid waste and emissions altogether. Cleaner technologies avoid the need for hazardous operating materials which require costly disposal methods. In contrast to expensive end-of-pipe investments, pollution prevention often significantly reduces environmental costs.

¹ VDI, the German Association of Technicians, together with German Industry representatives, have developed a guidance document on the definition of environmental protection costs and other terms of pollution prevention, VDI 2000.

For company internal calculation of environmental costs, expenditure for environmental protection is only one part of the coin. The costs of waste and emissions include much more than the respective pollution prevention or treatment facilities.

The concept of 'waste' has a double meaning. Waste is a material which has been purchased and paid for but which has not turned into a marketable product. Waste is therefore indicative of production inefficiency. Thus, the costs of wasted materials, capital and labor have to be added to arrive at total corporate environmental costs and a sound basis for further calculations and decisions. Waste in this context is used as general term for solid waste, waste water and air emissions, and thus comprises all **non-product output**.

Materials include water and energy.

	Environmental Protection Costs (Emission Treatment and Pollution Prevention)
+	Costs of wasted material
+	Costs of wasted capital and labor
=	Total corporate environmental costs

Figure 6: Total corporate environmental costs

A survey of several company projects has shown that the costs of waste disposal are typically 1 – 10 % of total environmental costs, while the purchase costs of the wasted materials represent 40 to 90 % of environmental costs depending on the business sector examined.

Material flows are money flows and can therefore be partly traced by conventional accounting systems. Also, when calculating investments for environmental protection, increased material and production efficiency needs consideration.

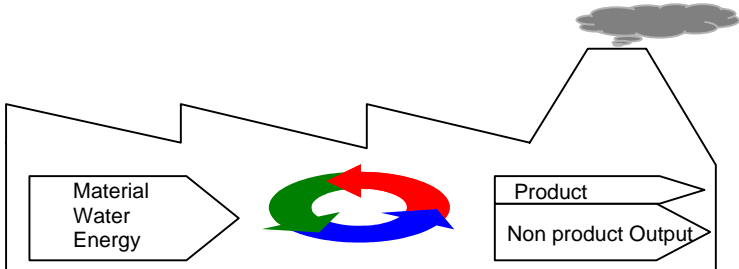

Figure 7: Material flows are money flows

The main problem associated with a systematic identification of the potential for material efficiency improvements lies in the traditional cost accounting systems which are not able to provide the relevant information on the company's physical structure, i.e. on the structure of its material flows. In particular the non-product output (waste, wastewater, etc.) is not being quantified and monetarised separately within accounting systems.

Recently, some methods have been developed to overcome these shortcomings.

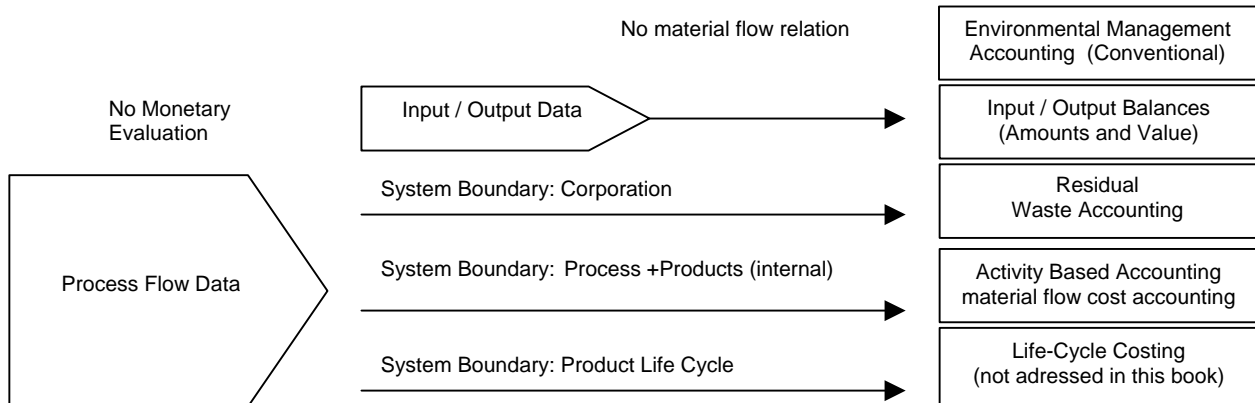

Figure 8: Categorization of environmental accounting by material flow orientation

(Source: adopted from IMU Augsburg)

Conventional environmental cost assessment did not consider material flows but mainly waste treatment and disposal costs as well as investments in end-of-pipe technologies. Later, corporate material flow balances were determined, but without systematically integrating the two information systems and without assessing the costs of material flows.

Residual waste accounting, in a subsequent phase, not only measures the costs of waste at their disposal costs, but also adds the material purchase values and pro-rata production costs. The system boundary is the corporation and identical to financial reporting. This approach is also at the core of the method described in the present paper which aims to provide a comprehensive statement of annual environmental costs.

Activity based costing improves company internal cost calculation by allocating costs typically found in overhead costs to the polluting activities and products. Significant material flows are traced throughout the company and their costs are allocated back to the polluting cost centers.

Flow cost accounting aims not merely to separate the costs of environmental protection, but to detect all material flows via the company's cost centers and to reassess production costs and percentage amounts added in the various phases of production, like estimated scrap percentages, waste rates, etc. Technical process flow charts support this approach. While the method in detail assesses the aggregated amounts and costs of material flows, which results in a better calculation of production costs, it avoids the need to separate the environment-related share and to obtain a complete list of other environmental costs. The system boundaries are the several production processes and cost centers in a company.

The **input/output-analysis of material flows** can be further subdivided from the company and process level to the product produced. The product assessment comprises two levels. Company internal is the subdivision of the process data to the produced products. The other level of product assessment leaves the company and follows the product throughout its life cycle by adding upstream and downstream life-cycle stages. This method, based on the material flow thinking, has been incorporated into ISO 14040 ff².

² International Standard Organisation (1998) ISO 14040, Life Cycle Assessment – Principles and Frameworks

A further step, a method called **life cycle costing**, tries to incorporate the related cost caused over the whole life cycle of a product. In life cycle costing the accounting boundaries of the company passed, as well as the normal time horizon of accounting which causes substantial methodological and practical problems. In theory, in competitive markets, the material purchase price is expected to reflect the costs that have been incurred up to selling point anyway. In addition, the estimation of external costs is cumbersome and doesn't provide much informative value, due to the low quality and inconsistency of the data. Thus, the methodology has not gained much attention. Life cycle costing is not adressed in this book.

Different companies might define "environmental costs" differently and use a variety of methods for cost assessment. Often, the distinction to health and safety and risk management is poses questions. For the purpose of internal management, focus should be not so much on the definition, as long as all significant and relevant costs are included in decision making.

Distribution to environmental media

Sometimes, national statistics laws or other assessment procedures require that environmental costs are categorized by environmental medium. Also for internal control purposes, the share of costs for waste disposal or water treatment can show interesting results and trends.

In the field of national integrated environmental and economic accounting, substantial methodological developments have taken place since the United Nations Statistics Division published Integrated Environmental and Economic Accounting: Handbook of National Accounting (SEEA) in 1993. In collaboration with the London Group on Environmental Accounting, the United Nations Statistics Division is currently revising the System of integrated Environmental and Economic Accounting (SEEA) to include new methodological developments, in particular in non-monetary (physical) accounting. The Nairobi Group consists of experts from international organizations (UNEP, Eurostat, World Conservation Union (IUCN), the World Bank, the United Nations Statistics Division), non- governmental organizations (World Wide Fund for Nature (WWF)) and national government offices. The United Nations Statistics Division worked closely with the Division for Sustainable Development of the Department of Economic and Social Affairs of the United Nations Secretariat in developing a framework and a set of indicators These indicators are currently being tested in several countries from all regions of the world ³.

The Environmental Protection and Ressource Management Accounts of SEEA 2000 provide for the assignment of transactions to the following classes:

- Protection of Ambient Air & Climate
- Waste Water Management
- Waste Management
- Protection of Soil & Ground Water
- Noise and Vibration Abatement
- Protection of Biodiversity and Landscape
- Protection against Radiation
- Research and Development
- Other Environmental Protection Activities

To provide for maximum consistency with existing international approaches, these classes have also been used for the EMA environmental cost roll over scheme, with the exemption of

³ for further information adress to: www.un.org/Depts/unsd/statcom and <http://ww2.statcan.ca/citygrp/london/publicrev/ch4intrev.pdf>

research and development activities, as they are covered under a separate line under the cost category "Prevention and Environmental Management" (see also figure 11).

Environmental cost/expenditure categories	Environmental Media								
	Air/Climate	Waste Water	Waste	Soil / Ground Water	Noise / Vibration	Biodiversity /Landscape	Radiation	Other	Total
1. Waste and Emission treatment									
2. Prevention and environmental management									
3. Material Purchase Value of non-product output									
4. Processing Costs of non-product output									
Σ Environmental Expenditure									
5. Environmental Revenues									

Figure 9: Overview on environmental cost roll over scheme

The environmental expenditures or costs should be assessed using two separate checklists: the controller identifies the environmental expenditure for each accounting/cost category, while the environmental manager calculates the costs for each environmental medium (waste, water, air, etc.). A cross-check of results for consistency is a central element of this approach and reveals full costs as well as opportunities for improvement.

In larger organizations, typically, two groups of experts in the company are involved:

- the "accounting" group, with the task of ascertaining purchase and production volumes (input/output), expenditure and revenues, cost center assessments, purchasing costs, internal prices, calculation and charge rates, and
- the "technology" group, with the task of material, water and energy balances, disposal and emission volumes and costs, process description and technical equipment for emission treatment and cleaner technologies, estimates of related work hours and operating materials as well as the distribution of total costs to the different environmental media.

In the methodology presented in this paper, the environmental cost roll over scheme is first used for the assessment of annual corporate environmental expenditure of the previous year. Subsequently, a break down to cost centers and processes can be performed, with guidance to be found in chapter 6. The focus of EMA is not on disclosure of annual environmental costs, but for further internal calculation, annual expenditure is the first step in a top down approach of environmental cost management. **Annual expenses** are the best available data source, a further distinction into cost centers, processes, products and material flow balances should be done in a **step by step** procedure, gradually improving the information system. Calculating savings, investment options or estimating future price changes requires consideration of future costs and is dealt with separately in chapter 8.

The environmental cost/expenditure categories follow the historic development of awareness for environmental cost categories.

The first block of environmental cost categories comprises conventional **waste disposal and emission treatment costs** including related labor and maintenance materials. Insurance and provisions for environmental liabilities also reflect the spirit of treatment instead of prevention. The first section corresponds to the conventional definition of environmental costs comprising all treatment, disposal and clean-up costs of existing waste and emissions (Cycle 1 in Fig. 10).

The second block is termed **prevention and environmental management** and adds the labor costs and external services for good housekeeping as well as the "environmental" share and extra costs of cleaner technologies and green purchase, if significant. Research and development for environmental projects is also part of pollution prevention. The main focus of the second block is on annual costs for prevention of waste and emissions, but without calculated cost savings. They include higher pro-rata costs for environment-friendly auxiliary and operating materials, low-emission process technologies and the development of environmentally benign products (Cycle 2 in Fig. 10).

Conventionally, three production factors are distinguished: materials, capital (investments, related annual depreciation and financing cost) and labor. The next two blocks consider the costs of wasted material, capital and labor due to inefficient production, generating waste and emissions.

In the third block, the **wasted material purchase value** is added. All non-product output is assessed by a material flow balance. Wasted materials are evaluated with their material purchase value or materials consumed value in case of stock management (Cycle 3 in Fig. 10).

Lastly, the **production costs of non-product output** are added with the respective production cost pro rata charges, which include labor hours, depreciation of machinery and operating materials and financing costs. In activity based costing and flow cost accounting the flows of residual materials are more precisely determined and allocated to cost centers and cost carriers (Cycle 3 in Fig. 10, but differently evaluated).

Environmental revenues derived from sales of waste or grants of subsidies are accounted for in a separate block.

Costs that are incurred outside the company and borne by the general public (external costs) or that are relevant to suppliers and consumers (life cycle costs) are not dealt with (Cycle 4 in Fig. 10).

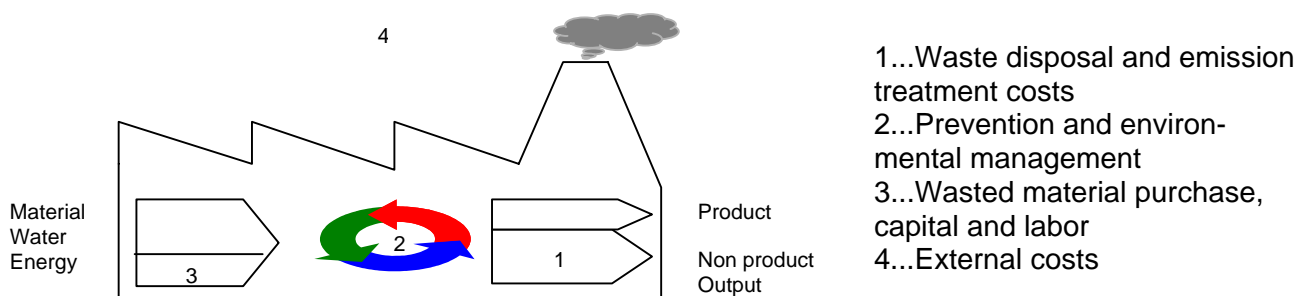

Figure 10: Different focus of environmental costs

(adopted from IMU-Augsburg)

4. ANNUAL CORPORATE ENVIRONMENTAL EXPENDITURE

Figure 10 shows the environmental cost roll over scheme developed for EMA. This chapter provides information on the different expenditure items or cost categories. The annex provides checklists for determination by environmental media.

Environmental media									
Environmental cost/expenditure categories	Air + Climate	Waste Water	Waste	Soil + Ground Water	Noise + Vibration	Biodiversity + Landscape	Radiation	Other	Total
1. Waste and Emission treatment									
1.1. Depreciation for related equipment									
1.2. Maintenance and operating materials and services									
1.3. Related Personnel									
1.4. Fees, Taxes, Charges									
1.5. Fines and penalties									
1.6. Insurance for environmental liabilities									
1.7. Provisions for clean up costs, remediation									
2. Prevention and environmental management									
2.1. External services for environmental management									
2.2. Personnel for general environmental management activities									
2.3. Research and Development									
2.4. Extra expenditure for cleaner technologies									
2.5. Other environmental management costs									
3. Material Purchase Value of non-product output									
3.1. Raw materials									
3.2. Packaging									
3.3. Auxiliary materials									
3.4. Operating materials									
3.5. Energy									
3.6. Water									
4. Processing Costs of non-product output									
Σ Environmental Expenditure									
5. Environmental Revenues									
5.1. Subsidies, Awards									
5.2. Other earnings									
Σ Environmental Revenues									

Figure 11: Environmental expenditure/costs and revenue/earnings

4.1. Waste and Emission treatment

Waste and emission treatment costs dealing with the non-product output of the company, should be attributed to the different environmental media. Waste collection, recycling and disposal costs are the most obvious to be monitored. This first section covers all kinds of treatment costs of non-product output while the following section addresses the prevention of waste and emissions.

4.1.1. Depreciation for related equipment

The most obvious assets in this section are refuse compactors, collection containers and vehicles, waste heat recovery systems, air pollution filters, noise abatement investments, sewage treatment plants, etc. But also watch out for more hidden equipment. Depending on the type of business and the state of environmental management, these plants may already be assigned to separate cost centers. The land/soil category may also include such areas as landscape protection, recultivation and repair of contaminated sites.

An asset (e.g. investment) is recognized in the balance sheet if future economic cost savings are likely and the value can be measured reliably. Investments are capitalized and accounted for by depreciation in the profit and loss account if they bear a future benefit, otherwise they are immediately expensed. As a rule, expenses which do not lead to future economic cost savings should be expensed in the year in which they occur. End-of-pipe technologies qualify as assets as they are required by regulatory authorities to continue with production. Their value can easily be measured as they are typically stand-alone treatment facilities.

The FEE, the European accountancy body, recommends that costs incurred to prevent future environmental impact should be capitalized whereas clean-up costs for past environmental damage should be expensed as they bear no future benefit. Likewise, the treatment costs of environmental contamination should generally be expensed. Capitalization of environmental costs is only allowed if future economic cost savings, increased efficiency or improved safety may be expected to result from present expenses.

In any type of activity and especially in investments which, in addition to their primary purpose (usually an economic one), also have an environmental aspect (and vice versa), there are substantial problems relating to the question of accrual and deferral, e.g. in connection with measures to improve workplace safety, security or infrastructure.

A clear allocation is only possible for investments in end-of-pipe technologies which, however, are unable to fully address an emission problem but usually only transpose it to another environmental medium (e.g. from air to soil). Rationalization investments which are implemented due to the advent of a new technology will, as a rule, lead to both a reduction of costs and emissions.

The problem in evaluating an end-of-pipe investment from an environmental point of view is due to the fact that there is no such thing as an environment protection investment proper as such a measure does not contribute to a sustainable solution of an ecological problem but merely helps to fight the symptoms. However, a separate assessment of an environment protection investment, e.g. a filter technology in the category of fixed assets, is usually only possible if it is an end-of-pipe investment.

Investments in environmental protection and pollution prevention measures are calculated in terms of annual depreciation, based on an assessment of the share of the investment

attributable to environmental protection. Investment is 100 % environmental in the case of end-of-pipe technologies. Investments which are incurred solely for the purpose of emission treatment are typically end-of-pipe technologies, i.e. devices which are installed for cleaning purposes after the production processes. Filters, waste collection equipment and waste water treatment plants are typical end-of-pipe-technologies which help to concentrate or hold back toxic substances. However, they usually do not solve the problem at source, but rather prevent uncontrolled release in exchange for controlled release.

The environmental manager will be the one to define the waste and emission treatment facilities of the company whereas the accountant may subsequently determine their purchase value and annual depreciation. When calculating costs instead of expenditure, the assessment of depreciation may be based on repurchasing values. If this is common practice in the company, financing costs may also be quoted.

4.1.2. Maintenance and operating material and services

Once the relevant environmental investments and equipment have been defined, the annual costs for related operating materials and equipment, maintenance, inspection etc. can be determined and attributed to this section.

4.1.3. Related Personnel

Time spent handling waste and emission related investments is calculated here. Time spent for inefficient production, generating waste, and time spent for general environmental management activities should be quoted elsewhere. This section mainly applies to the personnel of waste collection departments, and the people in charge of wastewater and air emission control, dealing directly with the identified waste and emissions streams and equipment.

4.1.4. Fees, Taxes, Charges

All disposal, sewer access and effluent fees, but also costs for specific licenses, or environmental taxes, if applicable, should be quoted here. In several countries, eco-taxes are levied on energy and water input, as well as packaging and sometimes specific hazardous chemicals. On the output side, taxes and charges can be levied on waste volumes, waste water and air emissions.

4.1.5. Fines and Penalties

In cases of severe non-compliance, fines and penalties may be charged. Several reporting guidelines request that these are disclosed separately, regardless of their amount in relation to other more significant expenditure. Still, they can not be found in many reports, probably because the companies at the forefront of voluntary environmental performance reporting are not the ones being charged fines and penalties.

4.1.6. Insurance for environmental liability

Firms can cover themselves against liability risks by way of insurance. The annual contributions to insurance against traditional damage to persons, goods and biodiversity caused by dangerous and potentially dangerous activities should be quoted here. Insurance

covering higher risks of fire or other damage to the production site or at transport due to dealing with hazardous substances and dangerous processes should also be quoted here.

Insurance for environmental liability are generally allocated to the other costs column rather than to specific environmental media.

Environmental liability aims at making the agent causing the environmental damage (the polluter) pay for repairing the damage that has been caused by him or her. Environmental regulations and accounting standards with regard to liability differ from nation to nation. Often, only dangerous and potentially dangerous activities which cause direct damage to persons (personal injury), goods (property damage) and sometimes biodiversity or contaminated sites are captured under the heading of strict liability. Strict liability means that there is no need to establish a fault on the part of the actor, but merely the fact that an action (or the omission thereof) has actually caused the damage. The EU Commission's white paper on environmental liability⁴ aims to also include damage to protected natural resources by non-dangerous fault based activities.

Availability of financial security, such as insurance, is important to ensure that liability is environmentally effective. The effectiveness of any legal liability regime further depends on the capacity of administrative and juridical authorities to treat cases expeditiously, as well as on the proper means of access to justice being available to the public.

The experience with US Superfund legislation (liability for cleaning up contaminated sites) shows the need to avoid loopholes enabling polluters to avoid liability by transferring hazardous activities to poorly capitalized firms which become insolvent in the event of significant damage. If firms can cover themselves against liability by way of insurance, they will not tend to resort to this perverse route.

Smaller firms, which often lack the resources needed to implement risk management systems that are as effective as those of their larger counterparts, often become responsible for a higher share of damage than their size would predict. When they cause damage, they are also less likely to have the financial resources to pay for redressing the damage. Insurance availability (or even requirement) reduces the risks companies are exposed to. They are thus also less inclined to try to circumvent liability.

The annual expenses for insurance are shown in the profit and loss account. But if insurance payments are required, companies must frequently foot part of the bill. Thus, even with risks covered by insurance, there remains damage to be covered by the firm. That is why less tangible liabilities must be quoted under the balance sheet.

4.1.7. Provisions for clean up costs, remediation, etc.

Provisions are a classic instrument of anchoring a company's risk protection scheme in the balance sheet and must be formed for contingent liabilities and potential losses from abeyant business transactions.

The function of provisions is to consider and anticipate future expenditure and obligations and to help the company protect itself against contingent risks. It should be noted that the provisions available under the commercial law and those recognized by the fiscal authorities may be quite different at times.

⁴ White paper on environmental liability, Commission of the European Communities, Brussels, February 2000

Provisions for expenditure which are admissible under domestic commercial law and provisions for deferred repairs and maintenance and for deferred removal of excavated material must generally not be carried as liabilities in accordance with International Accounting Standards (IAS) as the IASC stipulates in its definition of liabilities that these lead to current obligations which will in the future result in an outflow of resources. The above-mentioned provisions, however, constitute internal obligations which do not entail any direct liability vis-à-vis third persons. This means that there is no liability and, hence, no opportunity to plan ahead by forming provisions.

A liability is the present obligation of a company, arising from past events, the settlement of which is expected to result in future cash outflow or other use of resources, thus representing economic cost savings. The first uncertainty related to it is the occurrence of the liability as such (i.e., will the liability materialize or not?), whereas the second uncertainty concerns its amount (i.e., how much will it cost?).

"A contingency is a condition or situation, the ultimate outcome of which, gain or loss, will be confirmed only on the occurrence, or non-occurrence, of one or more future events ⁵".

Examples of (contingent) liabilities which may emerge from company's activities include

- Groundwater contamination (e.g. from working with solvent-containing substances)
- Surface water contamination (e.g. from spills and transport damage)
- Air emissions (e.g. sudden release due to a break-down of pollution treatment equipment)
- Energy emissions (e.g. radioactive emissions)
- Soil contamination (e.g. from contaminated surface water by missing protection troughs and collection tanks)

The liability vis-à-vis third persons underlying the formation of provisions may primarily be derived from the rules of public law and, to some extent, civil and criminal law. Environment protection tasks which companies must perform under public law include the duty to adapt equipment and procedures to the state of the art, to make provisions for waste removal and recycling at periodic intervals, to recultivate and dispose of substances at non-periodic intervals, and to clean up contaminated land.

Provisions for deferred removal of overburden (in mining) and clean-up of contaminated sites (where legally required) are also admissible under revenue tax law.

Duty to adapt equipment and procedures to the state of the art

As a result of advances in the state of the art, industrial plants commissioned in the past no longer meet the pertinent legal requirements. In order to comply with the new maximum values for critical emissions, the law usually grants transition periods for existing plants that are liable for approval. While, from a legal point of view, the duty to adapt arises as soon as the applicable law takes effect, the literature sometimes also stipulates an economic causal relationship in order for provisions to be formed.

Duty to remove and recycle wastes

If there is a back-log, at the balance-sheet cut-off date, in compliance with mandatory waste removal and recycling duties arising at periodic intervals, this must be accounted for by the formation of provisions.

Remediation and disposal duties

Especially in mining or in connection with the erection and disposal of power stations and lines, there are rules requiring comprehensive measures to restore the original landscape (e.g.

⁵ IASC (International Accounting Standards Committee) International Accounting Standards, p.181, London, 1995

run-of-the-river power stations) or controlled demolition of buildings (e.g. of nuclear power plants).

Clean-up of contaminated sites

Provisions for the clean-up of contaminated land must be formed when there is a likelihood of that duty arising, however, at the latest when the authority has knowledge of the contaminated site. In many countries, national tax laws require that a provision for future costs is calculated only once the legal obligation for this action has been established.

Provisions for the clean-up of contaminated land relate to soil and ground water. Remediation duties and aspects of landscape protection and biodiversity should be quoted in the respective column.

As regards the formation of provisions for specific environment protection measures, it may be summarized that in the event where a company is required to repair a damage to the environment which has already occurred, especially in the context of cleaning up contaminated land, a provision because of the economic causal relationship in the past is possible, whereas the duty to adapt to new technical standards usually precludes provisions in view of future revenue, unless the duty to adapt already existed at the cut-off date.

Therefore, risks and future requirements cannot be totally considered in the annual balance sheet. This creates the problem for cost accounting that the basis for total environmental costs is hard to estimate. In order to obtain a comprehensive list of environmental costs, it is advisable to assess all future obligations regardless of the requirements under commercial and fiscal law. This provides the necessary basis for internal calculations while, on the basis of the applicable national balance-sheet regulations, the possibility of an entry in the annual balance sheet may only be considered in a second phase.

4.2. Prevention and environmental management

In contrast to the first block dealing with emission treatment, this section deals with prevention costs and costs for general environmental management activities.

4.2.1. External services for environmental management

All external services for environment related consultants, training, inspections, audits and communication should be quoted here and, as far as possible, allocated to the relevant environmental media. In general, though, the amounts will be assigned to the column of "other expenses" as they basically cover the entire amount of company activities. It is imperative not to overestimate the environmental part of these services.

Also the costs for printing the environmental report and other communication-related activities like eco-sponsoring should be summarized under this heading. The related expenses will probably not have been systematically collected on one account or cost center but spread throughout the company and across accounts. A quick memory session on last year's projects and activities of the environmental team will make sure that all relevant expenditure can be traced back, and the allocation to expenditure items and cost centers can be improved.

4.2.2. Personnel for general environmental management activities

This section includes internal personnel for general environmental management activities, not directly related to emission treatment or the production of non-product output. Work hours for training programs including travel expenses, environmental management activities and

projects, audits, compliance and communication should be estimated and evaluated with the respective work hour costs.

4.2.3. Research and Development

External contracts and internal staff hours for environmental related research and development projects should be quoted separately from general environmental management activities, as their amount can sometimes be substantial, distorting comparison with previous years and other sites. Also some countries require disclosure of this figure.

Again, caution is required in order not to overestimate the environmental part. Nowadays in developed countries, considering environmental aspects in R+D projects is state of the art and should not be exaggerated. Cost savings for the natural environment are often a spin-off of measures to improve productivity and cost-effectiveness. Only if the main purpose of the project is to upgrade environmental performance, should the personal hours and related expenses be quoted under environment.

4.2.4. Extra expenditure for cleaner technologies

Most pollution prevention investments involve a share of environmental improvement and a share of improved production, with the respective shares to be estimated by an in-house review panel. Integrated or cleaner technologies allow for more efficient production processes, which reduce or prevent emission at source. Often, the new technology also uses less energy, is faster and has more production capacity. A new bottling plant, for instance, is less noisy, requires less water, and is equipped with an automatic supply of detergents. Environmental concerns were integrated when the device was designed. Because of the integration of environmental protection appliances and considerations, the question is often raised whether and to what degree cleaner technologies should be quoted as investments for environmental protection.

For imputation purposes, the cost difference of such an approach to an environmentally less favorable solution, with identical production values and state of the art, could be regarded. If there are significant differences and the investment was mainly done for environment protection purposes, the relevant share could be quoted as an environmental investment and the annual costs considered by depreciation. However, if the cleaner technology represents the current state of the art and was installed mainly as a regular replacement of an old device, it should not be regarded as environmental investment.

In contrast to end-of-pipe technologies, integrated anti-pollution technologies are part of the ordinary production assets. They are mainly bought for economic purposes. The environmentally induced part of cleaner technologies often cannot be determined. Sometimes, for the sake of enhancing their reputation, companies tend to overstate the environment-related part of their investments.

„Cleaner technologies should be treated as normal capital investment (assets) and not as environmental investment because

- The investment was made mainly for economic reasons.
- It is difficult to determine exactly the environmental element of the cleaner technology⁶ „.

Cleaner technologies are thereby automatically capitalized over their useful life and do not need to be expensed immediately. A further incentive may be that, as they do not appear

⁶ Schaltegger St. et.al., 1996, S. 85

under the heading of environmental management costs, the belief that environmental protection is invariably associated with costly investments, becomes more and more untenable. Still, investments in cleaner technologies should be mentioned in the notes to the financial and/or environmental report, as they are the core element of any solution consisting in prevention rather than treatment.

4.2.5. Other environmental management costs

Various costs related to environmental protection, e.g. extra costs for ecological procurement as compared to conventional materials, could be quoted here. Other environmental management activities like eco-sponsoring, are also to be found in this category. A major portion of costs in this category will most likely be related to external communication such as, e.g. the publication of the Environmental Report.

4.3. Material purchase value

Whatever has not left the company as a product is a sign of inefficient production and must by definition be waste and emissions. Determining the material flows for, at least, raw and auxiliary materials is therefore imperative for environmental cost assessment. The material purchase cost of wasted materials is the most important environmental cost factor, accounting for 40 to 90 % of total environmental costs, depending on the value of raw materials and the labor intensity of the sector. In companies with stock management, not the value for materials **purchased**, but **consumed for production** is used respectively.

	Costs of non product output in %
Material purchase value	60 %
Processing costs	20 %
Handling and Warehouse	10 %
Treatment and Disposal	10 %
Total costs of non-product output	100 %

Figure 12: Disposal Costs in Relation to Total Costs of Non-Product Output

Material purchase costs can make up to 70 % of total costs of a company. The greatest potential for cost savings are often in the materials cost block, but, material flows must be made visible before those savings can be identified. Reducing costs by cutting down on personnel may lead to loss of internal know-how, reduced work motivation and thus to economic losses.

Before waste and emissions occur, the materials concerned have been

- purchased (materials purchase value)
- transported, handled and stocked (costs for stock management, handling and transport)
- processed in various production steps (equipment depreciation, work time, auxiliary and operating materials, costs for finance etc.)
- collected as scrap, waste, etc., sorted, transported, treated, transported, stocked, again transported and finally
- disposed off (disposal fees).

Corporation thus pay three times for non- product output

1. at purchase
2. during production and
3. at disposal.

This section (4.3.) addresses the first and major part of these costs, wasted materials. The next section (4.4.) addresses handling and processing costs, and other wasted capital and labor costs. Disposal fees and related equipment have been addressed in section 4.1.4.

Material input in kilograms and monetary value can be assessed by analysing the relevant purchase, storage and production data. Further guidance on how to calculate a material flow balance will be provided in the next chapter. The input side of the material flow balance is then combined with the material purchase costs and the share of non-product output is attributed to the different environmental media. Fluctuations in raw material prices may be handled using average prices obtained by internal calculation, with data from cost accounting.

Raw materials

Non-product raw material output will mostly be disposed of as solid waste. Only in those rare cases where the company's product is gaseous (industrial gases, perfume), will it be found in the air. More common is a liquid product (beer, milk) that goes down with wastewater.

For a first estimate, company internal calculation percentages for scrap can be used to estimate the non-product output of raw materials. Eventually, with more detailed material flow balances, scrap percentages may need adjustment. The reasons, why raw materials do not become products are manifold and well worth study.

Product returns, obliteration, repackaging for other countries or specified customer requests, quality control, production losses, spoilage, wastage, decay in storage, shrinkage, etc. are some of the causes of waste generation that call for measures to increase production efficiency, which may be profitable both from an economic and ecological point of view.

Auxiliary materials

These materials become part of the product, but are not its main components. Often, they are not monitored separately. Again, their non-product output should be estimated in a first assessment and may then be monitored in more detailed cost accounting projects as described in Chapter 6.

Packaging

Purchased packaging for products will mostly leave the company with the product, but again a certain percentage for internal losses, e.g. due to repackaging for specific destinations, should be estimated. In some countries, taxes are levied on product packaging, which results in good monitoring for these items. The material purchase value of wasted product packaging should be estimated.

Packaging for purchased materials is included in the material price and can not be found in purchase records. If it can not be returned to the supplier, it ends up in waste and has to be disposed of at high costs. The material flow balance thus contains wasted product packaging and packaging for raw, auxiliary and operating materials.

Operating materials

Operating materials are by definition not contained in the product. Some materials are built into the office building, and stationery will have left the company via mail, but the major part of chemicals, solvents, detergents, paint, glue etc. goes to non-product output.

Operating materials for emission treatment, as defined in item 1.1, should be quoted separately in item 1.2. Only where this is not possible for lack of records and allocations, they may also be listed here. Operating materials are usually accounted for in the mark-up of production overhead costs on raw material costs and are quoted in item 4. Preferably, they should be deducted from overhead pro rata charges and be listed separately here.

It may be necessary to separate operating materials used in production from those used for administrative purposes. Generally, it may be assumed for assessment purposes that

operating materials for production by definition do not enter the product and, therefore, leave the firm as a non-product output. The case is different for operating materials used for administrative purposes as these are mostly printed matter and advertising materials which leave the company in the mail without causing any direct emissions at the system border of the company premises.

As a cross check for non-material product output, the material content of waste can be assessed and recalculated to the input materials. For solid waste, the material input is comparatively easy to assess. But some of the purchased materials do not end up in disposal, but are converted into air emissions or can be found in waste water. All volatile materials that have left the company via air emissions are summarized with their material purchase value under the column air. Thus, splitting up the material input to these 3 columns is necessary and can only be estimated between the production and environment manager, along with the information provided by the controller.

Energy

For energy input, the proportion of non-efficient energy conversion of production processes has to be estimated by the production manager. This part of the energy input value is attributed to the material purchase value of energy and attributed to the column air/climate and waste water, if it resulted in increased temperature. Losses of efficiency in energy production are assessed as part of the energy supply costs and also quoted here.

Water

All materials that can be found in waste water are summarized here. In addition, the purchase cost of water input is attributed to this column. For some sectors, especially in the food industry, some water goes to the product, in which case only a percentage of water input should be quoted under purchase value of non product output.

No material value should be found in the "other" column.

4.4. Processing costs

The above non-product output not only has material purchase value, but has also undergone processing in the company before leaving it again. Thus, wasted labor and capital costs should be added.

Work time lost due to inefficient production, and a share of depreciation for machinery as well as possible other costs should be accounted for under this item. For waste of raw materials and products in the various phases of production (usually solid or liquid) pro-rata production costs are calculated as a percentage based premium on the material purchase value. Wasted auxiliary and operating materials as well as packaging should either be quoted under non-product material output and not be listed again, or if they have not been included there, they should be added via the production costs. For energy and water, no estimated have to be made, as they have been included into material purchase.

In the energy column, processing costs only apply if the company produces its own energy. In analogy to the estimate for losses of efficiency in supplied energy costs, the appropriate proportion should also be listed here.

4.5. Environmental Revenues

These include only actual earnings from recycled materials or subsidies and can occur in all columns. Savings are treated separately under environmental cost savings addressed in chapter 8.

4.5.1. Subsidies, Awards

In many countries, capital investments for environmental protection and projects for environmental management enjoy subsidies, tax exemptions or other advantages. Subsidies should be quoted here, as they mean actual income. Tax exemptions and non fiscal advantages should be calculated when determining the cost savings arising from investments and projects (see Chapter 8), and not be quoted here.

Companies and their environmental managers sometimes receive external awards for their activities. When the prize is real money and not a symbol, the revenue should also be quoted here.

4.5.2. Other earnings

This section should include earnings from selling recyclable waste. Other possible earnings could derive from sharing the capacity of a waste water treatment plant or delivering energy produced on-site to the external grid.

5. SYSTEM BOUNDARY – COMPANY FENCE

5.1. Environmental aspects in the balance sheet

The function of financial accounting is to provide a corporate data base and to prepare the financial statement. The annual financial statements consist of balance sheet, profit and loss accounts, annex and management report.

Financial statements are submitted at annual intervals and must comply with regulatory assessment rules, with a distinction as regards their function being made between commercial and tax balance sheets. While the provisions of commercial law relating to assessment, as a basis for the commercial balance sheet, are based on creditor protection interests, the pertinent provisions of the tax law are designed to detect tax offences by prescribing as identical a procedure as possible for all taxpayers.

In the commercial balance, therefore, entrepreneurs pretend, if need arises, to be poorer than they actually are, and poorer than the tax balance sheet would suggest, which as a basis for tax assessment is intended to ensure as much as possible an equitable national tax revenue based on economic performance.

The balance sheet is a comparison of company assets on the one side, and of debt and equity on the other, as based on value, comprised in categories and arranged in the form of accounts or in sequence at a given cut-off date (balance sheet day).

It is supplemented with the profit and loss accounts, which contain all expenses and earnings incurred in one year. The annex and the management report give an explanation of figures, a description of the assessment methods used, and an outlook on the economic situation of the company.

Every accounting transaction is entered into two accounts. The systematic structure of accounts depends on the so-called chart of accounts, which functions as a requisite classification and organization system for consistency of bookkeeping. The chart of accounts is structured in the logic of the balance sheet and the profit and loss accounts. The structure of the chart of accounts is as follows:

Class of accounts	Content	Allocated to
0	Fixed Assets	Balance sheet
1	Stocks	
2	Other current assets and deferrals	
3	Provisions, accounts payable and deferrals	Profit and loss accounts
4	Operating earnings	
5	Material expenditure and services received	
6	Labor costs	
7	Depreciation and other operating expenses	
8	Financial earnings and expenses, taxes	Balance sheet
9	Equity capital, reserves, closing accounts	

Figure 13: Structure of the chart of accounts

Due to the uniform chart of accounts, expenditure for energy, waste disposal or detergents is posted by most bookkeepers into accounts with similar numbers. The standard chart of accounts thus has some resemblance with the periodic table of elements.

Every business transaction is posted into two accounts, e.g. rental expenses paid via the company's bank or as a receivable from customer y against the revenue account. The account thus shows all entries posted in the course of a year. The list of balances shows the sum total of all accounts and gives the best overview, due to the fact that it is not yet an aggregated representation like the one in the financial statements. The environmental cost roll over scheme in Chapter 4 is based on the determination of annual environmental expenditure and thus relies mainly on data derived from the profit and loss accounts.

Below is a short representation of the structure of a financial statement from which a combination with the environmentally relevant data may subsequently be derived. The balance sheet is a cut-off date comparison of assets and liabilities as at 31st from which the annual profit is derived. The debit side of the balance sheet shows the purposes for which the funds were used in the company (investments) while the credit side shows the origin of these funds (financing).

Equity capital (funds provided by the owner) is the balance between assets (investments, receivables, etc.) and borrowed capital. The balance sheet equation thus reads as follows:

Assets – borrowed capital = equity, or

Assets = borrowed capital + equity

This balance sheet equation is the basis from which the entire system of double-entry bookkeeping is derived.

Balance sheet on 31 December

Class of ac-accounts	Asset accounts (credit)	Class of ac-accounts	Liability accounts (debit)
0	<u>Fixed assets</u>	9	<u>Equity capital</u> Reserves Profits
1 2 2	<u>Current assets</u> Stocks Receivables Cash and bank balances	3	<u>Borrowed capital</u> Provisions Accounts payable Deferred items

Figure 14: Structure of the balance sheet

The credit side of the balance sheet shows the assets valued in monetary terms on the cut-off date. The debit side shows the funds used by the company, the financial resources, which are divided into equity or borrowed capital (debt).

The values for the balance sheet are obtained from the stocktaking process which takes place on the cut-off date and which comprises all assets and debts of a company based on quantity and stated in monetary terms. The further away a item is from its direct realization in cash, the more room for maneuver there is for valuation (fixed assets as compared to cash balance).

Fixed Assets

Accountants identify three categories of assets:

1. fixed (or long term) assets
2. current assets and
3. good will.

Fixed assets are intended to serve the company for longer than the accounting year. Data on them is piled together in the register of plant and equipment. Fixed assets are stated in the balance sheet with their historic purchase costs, reduced by annual depreciation over their expected life time. Cost accounting in contrast values fixed assets and the resulting depreciation by their estimated replacement costs.

Included under fixed assets are all those assets whose purpose on the cut-off date is to permanently support the company operations and whose useful life extends over several years. The purchase costs are distributed over the useful life via an annual depreciation. The so-called fixed-asset movement schedule shows all fixed assets complete with inventory number, purchase price and date, annual depreciation and value on cut-off date. Fixed assets comprise, inter alia,

- Non-built-up and built-up property
- Machines and installations
- Tools, industrial and business equipment
- Intangible assets such as patents, licenses and other rights
- Financial assets such as investments, securities

To determine the environmentally relevant fixed assets, it is imperative that all assets are assessed separately through cooperation between the environmental manager and other members of the environment protection team because bookkeeping does not distinguish between fixed assets used for emission treatment, cleaner technologies or other business property.

After the relevant processes, machinery and equipment and their original purchase costs have been determined, the annual depreciation for rollover to the environmental cost assessment according to the actual purchase values of the profit and loss accounts, or according to the cost accounting approach at replacement costs, possibly supplemented with a financing cost surplus, may be carried out.

The problem of separating the environmentally relevant portion of the company's property was already discussed in Chapter 4 in connection with items 1.1. and 2.3. of the environmental cost roll over scheme. To determine the existence of environmentally relevant fixed assets, the checklists included in the annex may also be useful.

Good will as a particular type of long term asset is recognized and included in the balance sheet only when money has been given to acquire it, which means the difference between the values in the accounts and the purchase price of a company. Only then has good will materialized and can be monetarized, whereas otherwise it is considered too vague for accounting standards. For capital budgeting, effects of environmental (mis)management on corporate image will be considered.

Current assets

The main current assets are cash balances, debtors (accounts receivable), stocks and work in progress.

1. Stocks

All purchased materials (raw, auxiliary and operating materials), which have not yet been processed in production, and all work in process and finished goods which have not yet been sold, are registered annually or regularly in the inventory in a stocktaking procedure. The latter thus provides a good overview (usually as of 31 December) of stocks purchased and consumed in a given year. The consumption of raw, auxiliary and operating materials is posted into the cost of sales account in the profit and loss accounts every year.

Depending on the bookkeeping, inventory management and production planning systems employed, different records concerning the values and quantities of raw, auxiliary and operating materials used by a company are available. Further information on the organization of inventory management and production planning and on the inference of the material flow balance are provided in chapters 5.3. and 5.4..

2. Receivables

These include

- Receivables from supplies and services rendered to customers
- Receivables from advance payments, loans, bills of exchange, etc.

There are no environmentally relevant items in this category.

3. Cash and bank balances

This item is self-explanatory and not environmentally relevant.

Equity capital

Equity capital comprises those assets which the partners have put at the firm's disposal (share or nominal capital), reserves (profit not paid out but retained by the company for specific purposes) and the profit or loss.

Borrowed capital

Borrowed capital shows the obligation of the firm to render services in cash or in kind (i.e. services or products).

1. Provisions

Provisions must be made by law for uncertain accounts payable (e.g. pensions, taxes) and potential losses from pending business transactions when a company prepares its financial statements. Provisions are also made for accounts payable the exact amount of which has not yet been determined (e.g. tax consultancy fees for preparation of financial statements). Other accepted provisions include provisions for poor maintenance (waste disposal), clean-up of contaminated sites, and reforestation (recultivation) which are also admissible under the tax law.

Provisions may always be made if a damage to the environment has already occurred, e.g. in the case of a clean-up of a contaminated site. Provisions for damage which is imminent but has not yet occurred are usually difficult to assess in compliance with the tax law and must therefore be considered as an imputed risk in cost accounting.

The financial statements list the estimated amounts of all accounts payable while the profit and loss accounts shows the annual allocation or liquidation of provisions which has altered the earnings of the business year. More explanations on environmentally relevant provisions are provided in Chapter 4 under item 1.7. of the environmental cost roll over scheme.

2. Accounts payable

Accounts payable for supplies and services are incurred by every company from the receipt of a supplier's invoice until the day of payment. Sometimes, each supplier has his separate account and the annual sales and invoices are stated there collectively, if they are not easily be found in the profit and loss accounts. For instance, the total quantity of a given chemical substance which has been purchased from a supplier, may be extracted from that supplier's collected invoices registered on his account. The invoices of the disposal firm may be dispersed across various accounts, but posted collectively into the supplier's account.

3. Deferred items

This item ensures compliance of the financial statement with the matching principle on the cut-off date 31 December and is not environmentally relevant.

5.2. Deriving expenditure from the profit and loss statement

The profit and loss statement may be arranged according to the expenditure or cost-categories-oriented format or to the operational (cost-of-sales) format. In the cost-categories-oriented format, all earnings and expenses of a period are listed. Operational expenditure is broken down into material and personnel expenditure, depreciation and other expenses. The accumulation and clearance of work in process and finished goods is determined by a stock-taking at year-end, assessed at production cost, and posted as correction of sales revenue.

In the cost-of-sales format, the actual sales of a period are compared only to those expenses which have been incurred for the manufacture of the products sold. The cost-of-sales format, therefore, requires a constant collection and assessment of inventory increases of finished products and work in process. The monthly earnings statement thus leads to a more explicit operating result than the cost-categories-oriented format in which the changes in inventory are not recorded during the year although it is more sophisticated and time-consuming in terms of the cost accounting system used. The cost-of-sales format is structured differently and distinguishes between production costs of sales, and chronologically separates distribution costs, administrative costs and other operating expenses. The profit for the year is identical in both formats.

In the following, we examined which items of the profit-and-loss account must be analyzed for the roll-over of environmental costs and under which items of the environmental cost scheme they are allocated. The cost-categories-oriented format is better suited for this purpose as the list of balances of the book-keeping department contains all the necessary information. In the cost-of-sales format, an analysis of both the accounts of the book-keeping department and of detailed cost evaluations must be performed in order to determine the environmental costs.

Cost-categories-oriented format	To do	Shown under item
Turnover/net sales	Determine actual quantities produced, sales figures, loss in storage, spoilage, returns etc. Establish actual product output and loss of products between production and sales.	3., 4., 1.4.
- Change in inventory	The quantities of non-product output between finished goods storage and sales department are posted at their material values (3.), pro-rata production costs (4.) and disposal costs (1.4.).	
- Work performed and capitalized	May be relevant for production costs of in-house facilities for the removal, treatment and prevention of wastes and emissions	1.1., seldom 2.3.
Other operating income	Revenue from subsidies, grants and sales of non-product output	5
- Materials	Determine share of non-product output of raw, auxiliary and operating materials and assess at material purchase costs. Energy and water supply costs should also be shown in this category, but are often posted under "other operating expenditure".	3

- Services (other external costs)	External services for maintenance of treatment facilities and cleaner technologies, general environment research and consultancy services, auditors, seminars, external information and communication etc. are scattered across a variety of accounts.	1.3., 2.1
- Personnel expenses	Determine work hours of staff in emission treatment facilities, cleaner technologies, general environmental management activities and labor pro rata cost for non-product output in the various phases of processing. Assessment is not derived from expense accounts of book-keeping unit, but according to work hour rates as established by the internal calculation procedures.	1.3., 2.2., 4.
- Depreciation	Define waste and emission treatment equipment. Search cleaner technologies and determine if they have been significantly more expensive in relation to state of the art. Determine related pro rata production costs and pro rata administrative costs for non-product output.	1.1., 2.3., 4
- Other operating expenses	Transport expenditure for wastes, disposal and collection fees, licenses, printing costs for environmental reporting, registration fees, eco-sponsoring, penalties, insurance premiums, provisions etc. are scattered across a variety of accounts. The checklists included in the annex are designed to assist the user in tracing and assessing costs. Also purchases of power, fuel and water can sometimes be found in this category, even though they belong under 'materials'.	1.4., 1.5., 1.6., 1.7., 2.3., 2.4.
- Other taxes	Environmental taxes, disposal and connection fees should be posted under this item.	1.4
= Operating profit, EBIT earnings before interest and tax		
+/- Financing	Not relevant; if environmental costs are assessed instead of expenditure, pro rata financing cost for depreciation of fixed assets may be calculated.	
= Profit (loss) on ordinary activities (after financial items and before tax)		
+/- extraordinary results	Not relevant, except in the case of break-downs and accidents and sudden discoveries of contaminated sites	1.4., 1.5.
- Taxes on income and earnings	Not relevant	
= Net earnings /Profit after tax		

Figure 15: Cost-categories-oriented format

The cost-of-sales format permits a certain leeway in the calculation of production costs as regards the inclusion of overhead costs of production. Material and production-related direct costs and special direct costs of production are always shown under 'production costs'. Material-related direct costs include raw and auxiliary materials as well as packaging materials allocated directly to a product, depending on the cost accounting system used. Production-related direct costs comprise wages in production, allocated according to work hour records

and cost centers. Material- and production-related overhead costs (other labor costs, operating materials, depreciation's for production plants) may be posted under production costs or under the item "other operating expenditure". To be able to determine the appropriate share of non-product output, a rather detailed break-down together with the cost accounting system used by the company must be provided.

Cost-of-sales format	To do	Shown under item
Sales revenue	Not relevant	
- Production costs of services supplied to achieve sales revenue	Determination of non-product output and production costs. Break-down according to accounts and items of environmental cost assessment scheme on the basis of cost accounting documents.	3., 4.
= Gross earnings from sales		
- Distribution costs	May also include costs of the environment report and other communication media.	2.4.
- Administrative costs	Analysis of accounts according to expenses for items 1 and 2.	1., 2.
Other operating revenue	Check subsidies for environmental measures and revenue for residual materials sold.	5
- Other operating expenditure	Analysis of accounts according to expenses for items 1 and 2.	1., 2.
- Other taxes	Environmental taxes, disposal and sewage fees should be posted under this item.	1.4.
= Operating result		

Figure 16: Cost-of-sales format

5.3. Material flow balance on corporate level

The basis of environmental performance improvements is the recording of material flows in kilograms by an Input-Output analysis. The system boundaries can be on the corporate level, or further split up to sites, cost centers, processes and product levels.

With rising costs for environmental compliance, disposal and the need to improve material efficiency in strongly competitive markets, tracking and tracing material flows throughout the company has been the major tool for detecting potential improvements in waste prevention and cleaner production. Likewise, calculating the related environmental costs and distributing them back to the polluting cost center, process or product (polluter pays principle, also in cost accounting) has gained importance for the correct calculation of the profitability of products, processes and production sites.

The material flow balance is an equation based on "what comes in must go out - or be stored". In a material flow balance information on both the materials used and the resulting amounts of product, waste and emissions are stated. All items are measured in physical units in terms of mass (kg, t) or energy (MJ, kWh). The purchased input is cross-checked with the amounts produced and sold as well as the resulting waste and emissions. The goal is to improve efficiency of material management both economically and environmentally.

A material flow balance can be made for a few selected materials or processes, or for all materials and wastes of an organization. The aim of process balances is to track materials on their way through the company. The starting point often is the corporate level, as much information is available on this system boundary. Also, this level is used for disclosure in environmental reports.

Ideally, the material flow balance can be summed up to show how much of the purchased material actually is processed into the sold product and how much is discharged as waste, waste water or emissions. It actually consists of a material flow balance in kilogram in combination with an energy balance in kWh and water balance in cubic meters.

Figure 17 is taken from a PREPARE Pollution Prevention project and shows that only 39% by material value of the raw materials and auxiliary materials purchased actually left the company as products. The rest ended up in the environment. As far as the materials input-output statement is concerned, the ratio was even less favourable: only 12 % by weight went into the product, the rest had to be disposed of at high costs or had to be treated with cleaning technologies. And the disposal costs accounted for only the lowest share in the environmental costs. It is obvious that this type of production is less than optimal both from an economic and from an ecological point of view.

In order to be able to aggregate and evaluate the data for such an analysis, the underlying information system has to provide records on the quantities purchased, produced and disposed of.

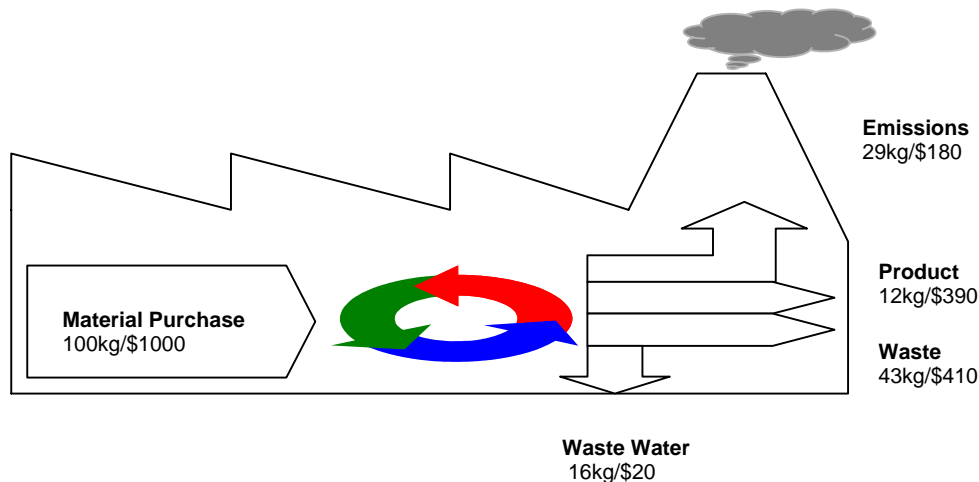

Figure 17: Material and Money Flows in a Paintshop

(Source: Dimitroff/Jasch/Schnitzer, 1997)

During their first environmental review, companies mostly draw up a screening material flow balance and do not go into much detail. On this basis, knowledge is gained on where to focus to achieve improvements in performance and information gathering. By improving the quality of the information available and the consistency of information systems, a regular monitoring system can be established. This monitoring system shows resource input and production and waste output on a monthly basis. As a next step, the material flows can be subdivided further according to processes and cost centres, and they can then also be subjected to monetary evaluation.

Figure 18 shows the generally applicable structure of the input-output balance at corporate level, which should also be used for environmental reporting. Specific subcategories will be needed for different sectors, but, it should always be possible to aggregate in a standardized manner, in order to be able to compare them.

Reclassifying accounting data after initial entry is often impossible and always time consuming and costly. Hence, the secret of success in all areas of accounting, including EMA, is to capture any information necessary for later analysis at the time when the data is entered. Modifying existing systems can also be costly, but, environmental considerations can often be built in when the system is adjusted for other reasons.

INPUT in kg/kWh	OUTPUT in kg
Raw materials	Product
Auxiliary materials	Main Product
Packaging	By Products
Operating materials	Waste
Merchandise	Municipal waste
Energy	Recycled waste
Gas	Hazardous waste
Coal	Waste Water
Fuel Oil	Amount
Other Fuels	Heavy metals
District heat	COD
Renewables (Biomass, Wood)	BOD
Solar, Wind, Water	Air-Emissions
Externally produced electricity	CO ₂
Internally produced electricity	CO
Water	NO _x
Municipal Water	SO ₂
Ground water	Dust
Spring water	FCKWs, NH ₄ , VOCs
Rain/ Surface Water	Ozone depleting substances

Figure 18: General Input/Output chart of accounts

The input-output balance at corporate level is drawn up on an annual or a monthly basis and is linked to the bookkeeping, cost accounting, storage and purchase systems. All material flows should be listed with their values and amounts per year. The roll-over scheme for the material flow balance should therefore record the amounts in kilograms, the values and the corresponding accounts. In addition, it should indicate whether materials are registered by material stock number and whether there is inventory management. It should also indicate whether there is consumption based stock withdrawal according to cost centres. As the first step in setting up the materials input-output statement at corporate level, quantitative data are collected from the accounting and stock-keeping systems. The accounting system offers annual data on input into the company as a whole, as well as some of the output (if it is paid for). All materials purchased during a year must either leave the company as a product, as waste or emission, or are stored on site.

Figure 19 shows the environmental roll-over scheme for the materials input-output statement. √ indicates the likely source of the data or which records are likely to be available. The objective should be to gradually improve the recording of material flows on a step by step procedure. There is not point in being complete in the first year, the goal is to gradually trace materials as completely and consistently as possible, in storage administration, cost centers and in production planning.

Roll over scheme for material flow balances	Amount in kg. KWh, l	Purchase value	Account number	Material stock number	Stock keeping	Production Planning Syst.	Direct costs	Overhead	Assigned to cost center	Oth. records/measurements	Calculation/estimates
Raw materials	√	√	√	√	√	√	√		√	√	
Auxiliary materials	√	√	√	√	√	√	√		√	√	
Packaging	√	√	√	√	√	√	√		√	√	
Operating materials	√	√	√	√				√	√	√	
Energy	√	√	√					√	√	√	
Water	√	√	√					√		√	
Product	√	√	√							√	
Waste	√		√					√	√	√	
Waste Water	√		√					√		√	√
Air-Emissions	√							√		√	√

Figure 19: Roll Over Scheme for Material flow balances

In order to compile an I/O (Input-Output Analysis) of material flows, it is best to start with the accounts in the list of balances of conventional bookkeeping. Only this list provides a complete overview (in monetary terms) of purchased raw materials, auxiliary and operating materials in a given month or year and what was paid for disposal, repairs, insurance, transportation etc. Each account of the profit and loss statement should be examined to determine whether any environmentally relevant movements or material flows may be recorded there. Personnel costs are not considered in a material flow balance.

The focus is on account class 5, which records the quantities of materials used. A second significant factor is costs and earnings in relation to the use and disposal of waste and emissions. The data determination will suggest ways for how to better structure the accounts in the list of balances.

Based on the I/O scheme in figure 18 and the accounts of the list of balances, a first breakdown for the I/O should be done and other company information sources identified. After the first breakdown of material flows in monetary terms the respective kilogram values need to be identified. For this purpose, the rollover scheme for material balances shown in figure 19, is helpful.

The vertical axis shows a breakdown of the I/O balance sheet for the entire company, which should already have been expanded using the company list of balances. The horizontal axis serves to examine data consistency and the relationship between the material flow balance and existing information systems and documentation. The first round of mass balancing will discover inconsistencies and information gaps, which will enable improvements in the organization of internal data.

It should be determined:

- Which of the substances and materials used in the production process are currently recorded in which accounts;

- Which accounts cost accounting treats as direct or overhead costs;
- Which quantities are used per year;
- To what extent material stock numbers exist,
- Whether warehousing is inventory-managed
- which materials are already contained in the production lists or formulae and
- in which way cost centers and cost carriers are being broken down.

With regard to waste and emissions, additional records (e.g. waste prevention plan) will be necessary to assess material input and output.

This roll-over scheme should also enable improvement of existing information systems and closing of information gaps. At the same time, it also serves to correlate data (through data processing).

It is important to define quantity units as uniformly as possible and to give preference to kilograms. It doesn't make sense to determine the units of materials used without an IT-supported production planning program and formula data base because they cannot be correlated with the output side.

For optimal data it is preferable to record from original invoices, and to enter not only the value but also the quantities received or used immediately when booking the invoice. Computerized record-keeping should enable tracking of quantities not only of material number assignments and warehouse accounting, but also in the recording of the original invoice in financial accounting. In this way, subsequent needs for information about quantities don't have to go back to the original invoices. With regard to a later evaluation, the ability to enter comments in the text column of the account form is also very important.

Such an evaluation may suggest:

- the creation of additional accounts, expansion or generation of additional material stock numbers;
- assignment of certain material groups (e.g. operating materials) to warehousing or production planning systems (e.g. packaging material);
- reorganization of cost accounting; and
- creation of additional records, especially with regard to emissions.

Clear definitions as to which elements of the Input/Output analysis are recorded in which accounts, which material numbers are assigned to which accounts and which materials are also recorded in stock management are essential. The objective is to obtain as complete as possible a listing of those substances that may be environmentally harmful and list them in separate accounts. This will help avoid having to break down accounts at a later date to show quantities used. Another area with optimization potential is the distribution of individual elements in cost accounting categories (direct costs, overhead costs, distribution to cost centers and cost carriers).

5.3.1. Raw Materials

Raw materials constitute the major part of a product. In many companies, warehouse management and production planning systems monitor their purchase and input into production.

In most companies, raw materials are already being recorded in a very detailed manner via accounts as well as material stock numbers, warehousing, production planning systems and cost accounting. Thus, material purchasing prices and quantity data are available in most cases. If need be, average prices can be used to calculate the weight values. The

assignment of accounts to material stock numbers sometimes raises questions. Raw materials and auxiliary materials are often assigned to own accounts, since they usually contain rather homogenous substances and significant purchase values.

5.3.2. Auxiliary Materials

Auxiliary materials are a part of the product, but are not obvious to the consumer (i.e. glue in a table or shoe).

The use of auxiliary materials is recorded less frequently in production planning systems. For this reason, quantities, flows and causes of non-efficient material use are often unknown. If, on the other hand, their purchase is inventory-managed through warehousing, annual use can be calculated.

5.3.3. Packaging

Packaging materials are purchased for use with the company's products. In countries with licensed packaging systems, such purchases are recorded in detail. Product packaging is usually integrated into production planning systems and in warehouse inventory management.

In most companies, material used for product packaging is usually considered as a separate cost category. It is partly integrated into the production planning systems and to that extent also recorded through material stock numbers. In some companies, packaging material is recorded through material numbers, but is not recorded in the warehouse inventory. Frequently, the some packaging material purchased is not assigned to the corresponding account and material stock numbers, but is subsumed under other operating costs or under overhead.

In many cases, account assignment does not correspond with cost category or material number assignment and should be re-examined. Records can be divided into single or multiple systems; multiple systems (such as pallets) can also be recorded through fixed assets. In the input/output analysis, average quantities received and sold should be recorded.

Packaging material delivered by suppliers is included in the purchase price and while often generating costs a second time via disposal costs, is only rarely recorded separately, despite the fact that it constitutes a large share of waste incurred. While product packaging leaves the company together with the product and must still be disposed of by either the retailer or the consumer, the company must dispose of supplied packaging material unless it is shipped back to the supplier.

5.3.4. Operating Materials

Operating materials are not part of the product, but are necessary for the production and administrative processes (i.e. solvents, small tools, office materials, etc.). They may contain harmful and toxic substances, e.g. for use in laboratory or workshop, which often have to be disposed of separately as hazardous waste. In many companies they are not traced by the storage administration system but are recorded as expenditures during purchasing. Very rarely is their consumption assigned to a cost center, which makes subsequent tracing difficult. While their consumption is recorded in the production overhead cost surcharges, a comparison with actual consumption is rarely done. If these materials are not included in the material stock management system, during the first year of environmental management accounting, it is best not to include them, but to focus on raw materials and auxiliary materials.

When recording operating materials, it should be ensured that no services and labor costs are entered into the accounts. These should be recorded separately.

A detailed breakdown of operating costs must reflect the special characteristics of a sector or company. In principle, all accounts of the profit and loss calculation should be examined for material flows in order to compile a complete material flow balance sheet. In practice, for the first balance sheet, available data from material accounting and the major elements on the list of balances will determine the scope.

Some accounts would require a disproportionate amount of time to determine quantities, so at least an estimate of the purchasing price in order to create a comparison base for subsequent years should be recorded.

The greatest potential for improvement is generally in the area of operating materials. Only very few companies record oils, lubricants, chemicals, paints, varnishes, diluting agents, glues, cleaning agents and other operating materials via material numbers and warehouse inventories. In most cases, there are no separate accounts for operating materials and they are not accounted for in production lists or production planning systems.

Cost centers assignment can also be improved in many ways. Frequently, operating materials disappear into overhead and cannot be traced in detail. It is therefore advisable to record and classify, to the extent possible, through material numbers or separate accounts, at least those operating materials related to hazardous waste disposal or other waste flows. Large quantities of many of these substances „disappear“ into accounts like „other operating materials“. It is very difficult to trace them by quantity later.

Repair materials and spare parts, as well as maintenance, are often recorded under entirely different categories. Since the repair and maintenance shop as well as the laboratory are particularly critical parts of the company with regards to environmentally relevant substances and the production of hazardous waste, it would be desirable to ensure that the materials used are disposed of in an appropriate manner and that, without exception, they are recorded in the inventory. This materials use can be kept on file through the special cost centers for shop and lab.

A similar approach applies to cleaning agents, which not all firms record in separate accounts. Ecological relevance and quantities will determine the degree of detail of those records.

With regard to administrative materials and food services, purchasing values should be used for monitoring, since the composition and amounts of waste are determined by factors independent of production. Detailed quantity determination is not a priority. However, as a result of these factors, types of emission independent of production (such as organic waste, toner cartridges) add to waste production.

5.3.5. Merchandise

Many companies buy products for trade without further processing, called merchandise. Often, product parts produced externally are just added to the final product without processing. The distinction to raw and auxiliary materials is whether incorporation into the product without significant process engineering and changes affecting emissions is possible. For a consistent analysis of material flows by weight, information on weight is needed, unless merchandise can be separated as well from product output, so that the material flow balance can be limited to the company's own production.

5.3.6. Energy

Energy purchases can easily be traced through the respective invoices. For company energy production input values are usually available. Energy consumption is relevant to all businesses and is important for the calculation of various air emissions. Energy input should be quoted in kWh. Conversion factors can be found in the appendix. The energy purchased should be adjusted by adding internal production and subtracting energy sold to others (e.g. electricity, steam).

5.3.7. Water

Water consumption comprises the sum of all fresh water purchased or obtained from surface and groundwater sources. Water used for cooling purposes should be recorded separately. Water input can be obtained from water supply invoices and must be estimated for supplies from own wells and surface water.

5.3.8. Product

The quantity of produced products can usually be determined from productions statistics and final stock records; however, sometimes it has to be calculated from turnover. Be aware that turnover is only a part of total production. Once a product is manufactured, there will be losses during warehousing and the company will consume a certain amount itself. All these losses occurring between production and turnover must be assigned to non-product output.

In some sectors, kilogram values are not easily available. In such cases, assessment of production, scrap and rejects cannot be done through production planning programs. At least for pilot project time frames, a complete listing and recording of the important quantity flows is essential.

By-products are all those products produced due to process engineering requirements during the manufacture of the primary product. All products whose sale results in earnings are already entered into the earnings accounts. However, a large portion of waste and emissions are not regarded as separate items in company accounting. The borderline between products, by-products and waste is not well defined and depends partially on how well the company separates by-products and waste, which in turn effects reuse and recycling options.

For the roll-over between inputs and outputs it is assumed that all inputs that do not leave the company as product will have to be disposed of as waste or emissions. Output of product packaging is also part of the product subgroup and should be examined for its correlation with the packaging material input.

5.3.9. Waste

Waste comprises all substances and objects to be disposed of. However, since different industries and sectors define the term waste differently, applicable national requirements must be taken into account. In the material flow balance, all waste streams should be quoted under the respective headings for hazardous, municipal and recycling, depending on national definitions and actual practices.

At the first year of material flow balancing a complete listing of waste and emissions is unlikely, because past records will not be available. However, a two-week, detailed waste recording should enable an estimate of the annual quantities.

Once the types of waste generated and their origins have been determined, ways can be examined to prevent or recycle waste. In this way, waste separation in the company can be designed for recycling. Data recording can be initiated. In next year's balancing of accounts, information gaps on the output side will have been significantly reduced, as well as the total amount of waste and emissions. It will also be able to thereby save money.

With regard to recording waste, a clear subdivision of present expenditure and revenue accounts is desirable, in order to have ready access to quantities actually disposed of. Often, some waste is given free of charge to employees and area residents. It should be made certain that quantity records exist for these cases as well, so that disposal can be documented.

The following accounts can be created in book keeping:

- Expenditures for disposal of non-hazardous wastes (municipal and recycling);
- Expenditures for disposal of hazardous wastes;
- Earnings from by-products and recyclable wastes.

Accounts for cleaning, transportation and third-party services should be examined as to whether they contain elements that should be assigned to disposal costs. In addition, the conventional system of rejects control can be expanded to include waste and emissions.

The purchasing department plays a key role in waste disposal. This department can provide information regarding the origin of waste and list product contents. In addition, Purchasing should record the origin and quantities of substances to be disposed of as hazardous or other waste. Combining procurement and disposal responsibilities changes awareness of the purchase department.

A measuring or weighing system should be installed in Purchasing and in Shipping Preparation, in order to obtain information about the quantity of waste.

If waste is potentially recyclable, but is collected and disposed of as municipal waste, that is where it belongs. Only when materials destined for recycling are collected and forwarded to recycling plants, they are recorded under that category. Given that there are different national laws regarding incineration and disposal, after delivering waste to authorized waste collectors the company may have little knowledge as to whether the waste is incinerated or dumped. Therefore, the appropriate category is "municipal". When companies have their own dumps, the material should also be recorded under "municipal".

For companies that maintain their own incineration plants, the material to be disposed of is no longer considered waste, as it does not leave the company but is transformed into energy. In the section "electricity produced on site" the respective kWh should be recorded.

Most countries have regulations requiring detailed record keeping of hazardous waste disposal. Additionally, some countries require companies to monitor other waste streams (municipal and recycling). Company disposal invoices can sometimes be used to assess the amounts of municipal waste. In all cases, monitoring waste streams by cost centers or for the whole site over several weeks can provide useful insights into non-material product output and improvement options. All waste should be calculated or converted into metric tons.

5.3.10. Waste Water

The amount and content of wastewater is often not monitored on a regular basis, as such monitoring is only required for some sectors. Many countries require spot checks for companies that pass waste water directly into the environment, from which annual quantity

estimates can be made. Companies that pass the waste water indirectly via municipal sewer systems must use calculations from which annual quantities can be derived. If the wastewater burden derived from organic materials, heavy metals etc. does not have to be measured, an estimate should be made by Process Engineering.

5.3.11. Air emissions

Waste heat and substances in air emissions have to be estimated by the type of energy and materials and processes used (e.g. solvents, cleaning agents). For commonly used conversion factors for fuels please see the appendix.

The fossil fuel energy (primary energy) used to generate the electricity purchased by an organization depends heavily on the local or national energy mix and technology used to generate electricity. Several countries publish national conversion factors for the corresponding primary energy input. Country specific data for fossil, nuclear- and hydropower electricity generation can be used to calculate the specific primary energy input and related CO₂ and other emissions. As energy markets are being liberalized, the situation will become even more complex.

The Kyoto Protocol⁷ covers industrial and energy linked global warming gas emissions. The main substances are Carbon Dioxide, Methane, Nitrous Oxides, Sulfur Hexafluoride, Perfluorocarbons and Hydrofluorocarbons, resulting from fuel combustion, process reactions and treatment processes. All greenhouse gas emissions should be calculated in metric tons of CO₂ equivalent. Conversion factors for the global warming potential based on CO₂ can be found in the appendix.

CFC emissions contribute to the depletion of the ozone layer. The Montreal Protocol covers ozone-depleting substances and standardizes their ozone depletion potential (ODP) in relation to the reference substance CFC-11. Once the volumes purchased have been assessed, these conversion factors (see appendix) should be applied to calculate ozone-depleting emissions in metric tons of CFC11 equivalents.

Even if a certain substance is not emitted, it should be recorded in the input/output balance as n.r. (Not relevant). This will indicate to the internal or external reader that certain substances were not omitted from consideration, but were not used.

5.4. Organization of stock management and production planning

Input/Output items are partly derived from the profit and loss accounts. Only this list is a complete record of all materials purchased (in value terms). To the extent that a company works with material classification numbers, the amounts purchased can be derived relatively easily from the storage system.

Checking stock accounts and flow accounts for consistency is crucial for the material balance. It should be possible at least with regard to raw and auxiliary materials and product packaging, that in any given year the balance sheet can be derived in value and volume from the balance sheet of the previous year plus the flow of accounts of that year.

⁷ The text of the Protocol to the UNFCCC was adopted at the United Nations Framework Convention on Climate Change (UNFCCC) in Kyoto, Japan in December 1997.

Systems of increasing complexity can be used for storage administration, depending on the size of the company and the value of the product warehouse: Examples ranked by complexity of the information system are:

1. Material purchase value is recorded as expenditure directly during procurement; a further tracking of quantities used is not possible. This system is common in small and medium-sized enterprises and with operating materials.
2. Material stock numbers are used to record material quantities as well, but this system does not record materials on stock. The system enables determination of annual quantities purchased, but not the place and time of consumption in the company.
3. Material is taken from the warehouse by means of a stock issuing form. Here product use can be determined exactly by value and quantity.
4. The company uses internal order forms connected to the production planning system. Thereby, stock issuing can be tracked by order.
5. Stock issuing is also assigned by cost centers.
6. Waste and disposal costs and quantities are also recorded through storage administration by way of internal records.
7. Waste and disposal costs are additionally assigned to the relevant costs centers.

The following output systems can be differentiated:

1. Only turnover is known, not actual production volume;
2. Production statistics exist, maintained by means of the outgoing stock;
3. There is a production planning program that calculates estimated input and output based on the production planning system; it is checked against actual input and output by way of order forms;
4. Product and non-product output (scrap, losses, waste and emissions) can be tracked by cost centers.

Discrepancies between material purchase and material consumption (in the company) are important because, apart from the time lag, losses in interim storage can cause considerable waste and costs that can be traced to a variety of causes. Losses are frequently caused by employees' private use of materials, in addition to material aging in the warehouse, becoming obsolete or unusable, or contaminated through careless treatment or otherwise destroyed.

In part, discrepancies between production output and sales have similar causes. In addition, there are discrepancies due to usage within the company, returns, quality control, repackaging for different destinations or customer requirements, etc.

The discrepancy between materials consumed and production output reflect actual process-based waste and scrap. This review is distorted if material purchase must be compared against sales because of inadequate internal data systems. Inventory losses should be addressed separately as each type of loss requires different actions for improvement. The amount of sales (Turnover) needs be considered only for the calculation of its difference to production volume and for an assessment of the underlying causes.

Ideally, an Input/Output comparison should compare materials consumed in production against the actual production volume. Stock losses should be quoted separately. However, this is only possible if a sophisticated production planning system is in place, in which auxiliary and operating materials and waste as well as raw materials and packaging are considered.

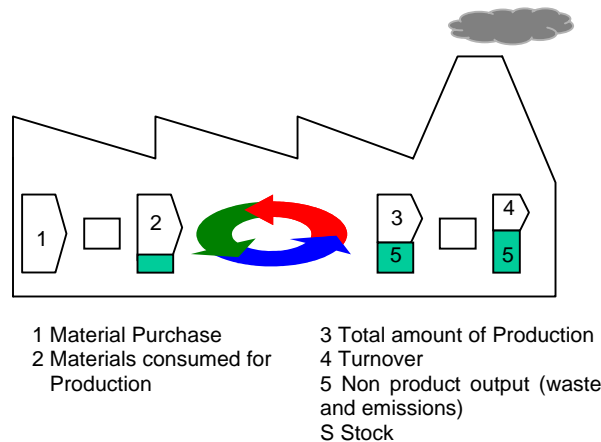

Figure 20: Differences between Material Purchase and Use for Production

It is essential that quantity units are defined or recalculated into the mass unit (kg) in the material flow balance. Recording units of materials used (such as five boxes of paint) only makes sense if production planning has a computer program in place that correlates processed units to the resulting products. Actual monitoring and recalculation of estimated consumption ratios provides helpful saving potentials. A weight balance in kilogram of materials consumed and processed and the resulting products and waste is desired. It has proved helpful to determine the relevant kilogram data at the same time when a material stock number is assigned to a specific material within the storage system. In this manner, all relevant data such as price, quantity, conversion factors and material numbers are recorded when the supplier invoice is recorded.

The material flow balance can be checked for consistency by comparing it, to the extent possible, to material supply from stock keeping, sales information and production lists. For auxiliary and raw materials, packaging materials and final products, this can be done by adjusting the existent computer software; once this is accomplished, relatively little work is involved.

The procedure becomes more complicated, however, when the majority of operational materials affecting the environment, like chemicals, paints and lacquers, cleaning materials, workshop needs, etc. that affect emissions and proper disposal, cannot be extracted through material numbers. In this case, the amounts used cannot be traced back. In many enterprises there are a large number of such materials without material numbers that vanish on stock and in overhead and whose values and volumes cannot be traced.

Distributing direct costs and general overhead: Many companies include only raw materials and some packaging materials in direct costs, but not auxiliary and operational materials, other packaging materials and the cost of disposal. Therefore, checking for consistency provides significant potential for account arrangement and classification criteria optimization between material numbers and the classification of accounts and costs.

In the interest of efficient use of information (and to eliminate the need to go back to original invoices for information, as some companies have to do) the departments involved should agree on a record organization system. Purchasing and Material Management will thus

become more important in developing an inventory system for materials that potentially affect the environment and corresponding record-keeping obligations.

Existing production planning systems can deal with thousands of materials. Amounts are recorded as soon as materials are ordered or stored, and again when they are taken out of storage and moved into the production process. By directly linking conversion factors to material numbers the computer can automatically calculate amounts in kilograms.

The company's production planning system should be checked on a regular basis for consistency between actual data on materials purchased and production output. This procedure is shown in Figure 21. It is often the case that scrap percentages, which have been rough estimates, need to be adjusted. Automated cutting and dosage plants frequently have much better amortization times than expected since losses were often higher than estimated.

In the first year of material flow analysis, it is sufficient to trace and account for about 70% of all materials (mainly raw materials and packaging, and if possible auxiliary materials also) in the material flow balance. Likely immediate results are:

- Adjustment of the percentages used to calculate scrap resulting from raw materials and products,
- Improved monitoring of materials and products in stock,
- Installation of computer-aided design and cutting machinery,
- Automated dosage equipment for operating materials, and
- A marked improvement and consistency in information systems and records based on them.

All this should significantly increase profit. In the following years, consistency can be improved to include all material input as well as office material monitoring within the material storage system and internal ordering instructions. Be aware that such changes interfere with individuals' spheres of influence. This may provoke resistance to a system that prohibits departments from placing external orders but directs all orders to the central corporate warehouse.

The production planning system is sometimes used for standard production units only, not for custom-designed products. Eventually, these should also be integrated into the material monitoring system.

Sometimes waste is not monitored on a regular basis. Once companies realize the monetary value of waste and the resulting savings potential, they will install waste monitoring systems not only for the whole company, but at cost centers, so that amounts and costs of waste can be attributed to the polluting production lines.

There can be significant time lags between material purchasing, material use in production, the finished product being put in stock and final delivery to and invoicing of the customer. As production patterns change, emissions may occur much later than material inputs or product output. These time distortions can be limited once the material flow balance relates material input to production (consumption and not purchase) to relating product output of production (and not product turnover).

Changes in stock as well as in material input and product output can be significant. There are major losses of materials and products in stock, which should be accounted for by separately adding them to the material flow balance.

Companies wield a very powerful controlling tool by constantly refining the material flow balance at the corporate level, which should be done on a monthly basis together with the financial accounting data.

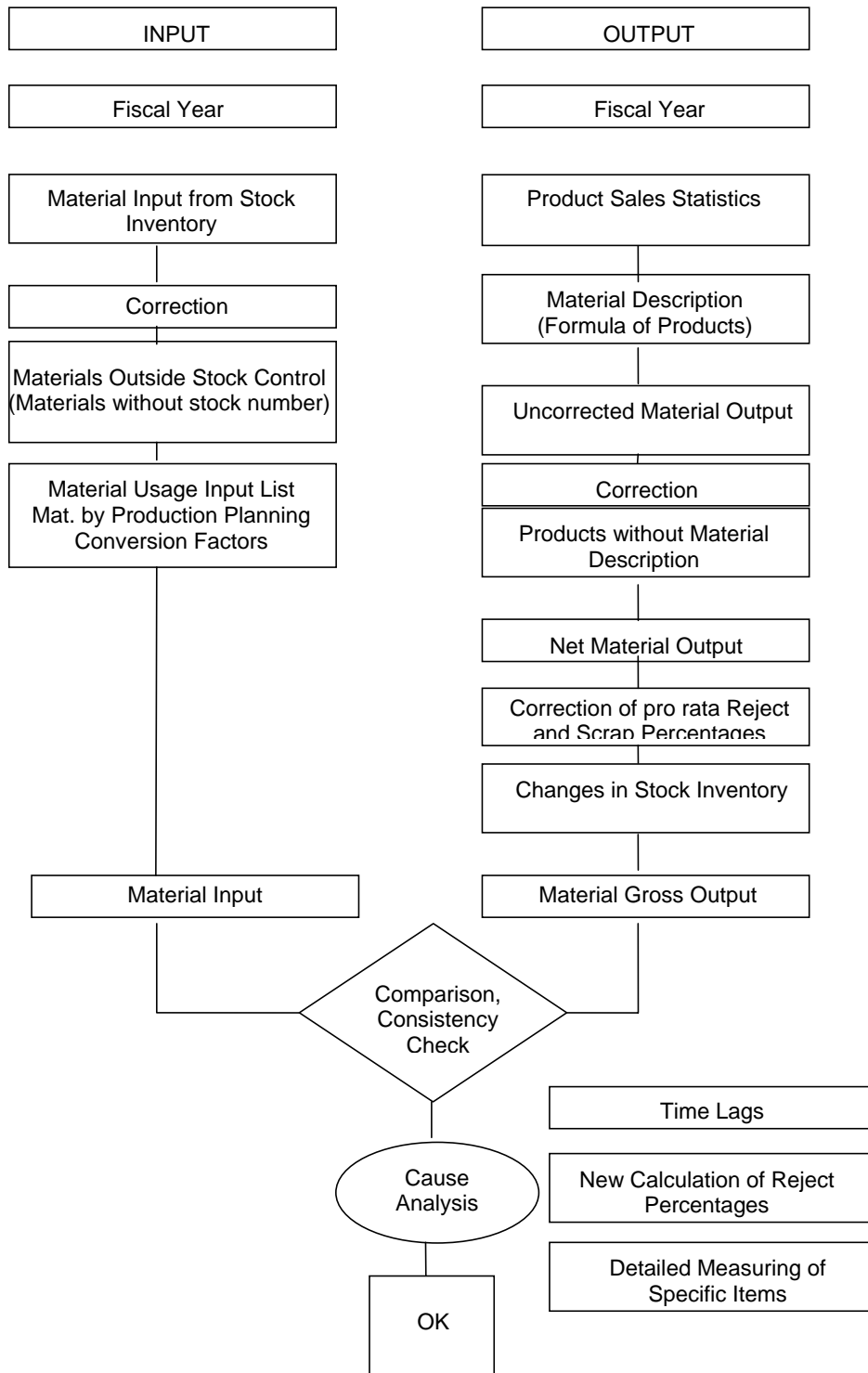

Figure 21: Consistency Check with the Production Planning System

5.5. Consistency and Consolidation

The information gathered from environmental management accounting on the corporate level can and should be divided into accounting by divisions, sites, cost centers and products. As product managers, cost centers, sites, divisions and top managers will probably collect and be interested in information with different system boundaries, aggregation issues have to be dealt with.

EMA covers the preparation and provision of environmental cost and performance information for the use of multiple internal and external stakeholder groups. This information can be aggregated for different decision levels in the company and is often presented in a separate environmental report for external stakeholders. A well structured and consistent underlying information system is crucial for the quality and credibility of the data presented.

Over the last decade, significant progress has been made in identifying the core environmental issues to be reported on and the appropriate performance indicators through which performance can be both computed and communicated. At the same time, however, little progress has been made in establishing the conceptual foundations necessary to provide the secure foundation that any form of internal or public reporting requires and that is a prerequisite for comparison and benchmarking.

5.5.1. Consistency

Internal and external users of environmental information need to monitor and compare the results of environmental performance and cost assessment over time in order to identify significant trends. Some also wish to make comparisons with other sites or competitors. Consistency in the recognition, measurement and presentation of environmental information is therefore essential.

Consistency should initially be established internally, determined by the information needs of the corporation's user groups. A data determination and internal assessment guide with clear definitions of what to include and where to take it from, as well as conversion factors proves helpful. Caution is needed when seeking to benchmark between companies in the same sector, as even minor differences in processes, products or vertical integration through the product life cycle can significantly distort results. As with financial reporting, it is important that corresponding information for different periods be reported on comparable and consistent basis. Some more guidance on this aspect is also contained in chapter 7 on environmental performance evaluation.

An important task for data determination is defining guidelines for the registration and separation of the environmental expenditures dealt within the environmental information system. It must be ensured that the data in future periods will be calculated with the same basis in mind. Only when the calculation method is defined and consistent over years, can comparison of absolute values in tons or money and the resulting indicators over time or between different divisions bring meaningful results. Thus it is suggested, that the data registration criteria for each expenditure item in the roll over scheme should be documented as such:

- Description of expenditure item or environmental indicator (absolute or relative)
- Definition of the base data and related denominators
- Data sources
- Conversion factors and definitions
- Frequency of data collection and indicator calculation
- Responsibility for data registration

Figure 22 shows the most likely data sources for the roll over of environmental expenditures and costs. The first round of determination of total environmental expenditure will probably also result in improvements of the consistency of the data sources.

Data sources for environmental Expenditure/cost roll over	Balance sheet	Profit and loss accounts	Material flow balance	Material stock numbers	Stockkeeping	Product. Planning System	Direct costs	Overhead	Assigned to cost center	Oth. records/measurements	Calculation/estimates
1. Waste and Emission treatment											
1.1. Depreciation for related equipment	√	√						√	√	√	
1.2. Maintenance and operating materials and services		√	√					√	√		
1.3. Related Personnel								√	√	√	√
1.4. Fees, Taxes, Charges		√						√			
1.5. Fines and penalties		√						√			
1.6. Insurance for environmental liabilities		√						√			
1.7. Provisions for clean-up costs, remediation	√	√						√			√
2. Prevention and environmental management											
2.1. External services for environmental management		√						√	√		√
2.2. Personnel for general environmental management activities								√		√	√
2.3. Research and Development		√						√	√		
2.4. Extra expenditure for cleaner technologies		√						√			
2.5. Other environmental management costs		√						√			
3. Material Purchase Value of non-product output											
3.1. Raw materials		√	√	√	√	√	√				
3.2. Packaging		√	√	√	√	√	√				
3.3. Auxiliary materials		√	√	√	√			√	√		
3.4. Operating materials		√	√	√	√			√	√		
3.5. Energy		√	√					√	√	√	
3.6. Water		√	√					√	√	√	√
4. Processing Costs of non-product output							√				
Σ Environmental Expenditure											
5. Environmental Revenues											
5.1. Subsidies, Awards		√						√			
5.2. Other earnings		√						√			
Σ Environmental Revenues											

Figure 22: Data Sources for Environmental Expenditure/Cost Roll Over

For the material flow balance, it is recommended to enlarge on a sector specific basis enlarge the standardized input output framework. Figure 23 shows an example for breweries.

5.5.2. System boundaries

The essential system boundary for corporations is the company fence and the balance sheet. In-depth data are not often available, i.e. balance sheet data for sites within the corporation. In addition, data from suppliers and consumers are not available, which is why life cycle costing as well as life-cycle analysis continually fails due to problems of data availability. For comparison and benchmarking projects, it is important that the participating sites have a rough process flow chart scheme. Only when the range of products, including the packaging are homogeneous, will it be possible to have valid data. Outsourcing of critical processes, like transport and delivery, cleaning and sanitation, etc. significantly influences material input and emissions data.

Breweries provide a good example of these effects. For data comparison between production sites there is a significant difference whether, for example, a malting house is a component of the brewery, or whether the brewery acquires its malt from external sources. Similarly, it is of importance for comparison of water and energy data whether bottling occurs on all or only on certain sites and whether all sites bottle in glass and aluminium cans and kegs. In Austria, most breweries also have a non-alcoholic production line for lemonade, which can also distort comparison. Figure 24 shows the production flow scheme of a brewery.

Still, most corporations and products are more complex than breweries, so the definition of system boundaries has to focus on specific process steps for specified products and defined product life-cycle stages. When comparing companies and products with regard to environmental performance, it is essential that the system boundaries upstream and downstream are identical. But big organizations tend to include most of a product life-cycle stages within their own production plants, while small companies are focussed on specific production steps and outsource other production steps.

Outsourcing of critical processes with effects on technology and emissions, has also become popular recently. This is often the case for electro-plating processes, which, because of tightened legal compliance requirements is not continued in outdated on-site equipment, but provided by specialized firms. If the new supplier is equipped with modern technologies better than the old devices, outsourcing can actually be environmental beneficial. But, the effect can be opposite too.

For performance evaluation and product life cycle assessment (LCA), the production steps and processes covered by the companies or product systems analyzed, must be carefully defined, so that the production steps covered by an input output analysis are identical. Figure 25 shows the product life-cycle scheme. Data comparison within sites, processes and products requires that the system boundaries of the participant are comparable, otherwise the results will be meaningless.

5.5.3. Consolidation

Some corporations with many sites and companies have started internal environmental information systems that collect data from all sites and affiliates and produce corporate environmental reports in addition to site-specific emission monitoring and reporting. Often, international corporations comprise numerous sites and public entities, which deliver to subsidiaries and affiliates of the same corporation world-wide.

Adjustment of internal deliveries within related plants of a corporation is often only performed for financial data, but not for material flow and other environmental data. Thus, caution has to be paid when relating these figures to each other.

Companies with one or more subsidiaries and affiliates produce consolidated financial statements, as user groups, especially investors, are interested in the earning power and risk structure of the whole group. Consolidation of environmental data is of equal relevance, as users are interested to see how transnational organizations with subsidiaries and associated companies operate in different countries worldwide, and if they apply the same standards for pollution, safety and environmental policy and management throughout the group.

It is essential that the boundaries of the reporting entity are clearly defined and explicitly reported. Financial accounting and reporting standards which deal with different legal constructs through which corporate control is exercised (e.g. joint ventures, associates or subsidiary operations) have hardly ever been used for environmental reporting yet.

For the aggregation of environmental data, the following issues may impact on interpretation:

- Establishment or closing of production lines or treatment facilities of the operation
- Acquisition or sale of sites and subsidiaries (and the need to adjust prior year data accordingly)
- Outsourcing and its impact on historic trend data
- Non-adjustment for internal deliveries within consolidated sites.

An important adjustment is for internal deliveries of materials and products. If only the inputs and outputs of each site are aggregated without adjustment of supply from within the corporation, there will be numerous double countings. On the other hand, data for turnover and profit will have been adjusted not net values because of financial reporting standards requirements. Thus, the two figures can no longer be related to each other.

Reporting can be product-, site- or corporation- oriented. Some companies publish for all three levels. Corporate reports are mainly published by multinational companies and contain data, which has to be aggregated from different sites and companies. Often, corporations own shares but not total ownership, of their reporting entities. Thus, questions of consolidation as in financial reporting arise.

Financial accounting standards have defined three methods of consolidation, depending on the share with which a company participates in another company.

1. **Full consolidation:** is used by the parent company which controls the majority of the voting rights of a subsidiary (50 to 100 %). The parent overtakes the complete profit and loss account by adding together assets, liabilities, equity, earnings and expenses and deletes all internal deliveries within the group.
2. The **equity method** is used for associates, which are neither a subsidiary nor a joint venture to the parent, but in which he has a significant influence (between 20 to 49 %). The equity method considers the actual change in value of the share of the equity, but does not integrate sales, assets or liabilities. All internal deliveries are eliminated.
3. The **proportionate method** is applied for investments between 1 to 19 % of the share capital as well as for joint ventures. Typically, the value of the shares in the books remains unadjusted till significant changes occur.

In environmental reports the degree of ownership of sites is hardly ever mentioned. Also the method of consolidation is hardly ever disclosed or even discussed. In practice, many companies fully consolidate subsidiaries of more than 50 %, but without adjustment for internal deliveries, and neglecting minority investments. Thus, the consolidating practices and system boundaries for financial and environmental reporting can differ significantly. Comparison and

relating financial data like turnover and EBIT to environmental data like energy use or total CO2 emissions, is often significantly hampered.

Resulting recommendations are:

1. All sites and subsidiaries should apply the same definitions for data collection.
2. All sites and subsidiaries should apply the same input/output chart of accounts for the material flow balance.
3. Before benchmarking sites, process flow charts must be compared and harmonized.
4. All sites and subsidiaries should apply the same consolidation methods.
5. The consolidation principles should be disclosed.
6. Internal deliveries should be adjusted.
7. When calculating key figures, the same consolidating principles should be used as in financial and environmental accounting.
8. In environmental reports, total sales, EBIT and share of each company should be disclosed.

INPUT	OUTPUT
Raw materials	Product
Barley	Bottled beer
Wheat	Beer in kegs
Malt	Canned beer
Hops	Alcohol-free drinks
Brewing water	By- products
Auxiliary Materials	Malt
Additives (beer)	Malt dust
Additives (lemonade)	Hops
Laboratory materials	Barley waste
Packaging	Spent grains
Crates (new)	Silicic acid
Bottles	Waste
Cans	<i>Total waste for recycling</i>
Kegs	Glass
Palettes	Metal
Labels	Etiquettes
Foil	Plastics
Corks	Paper, cardboard
Caps	<i>Total Municipal Waste</i>
Operational Materials	<i>Total Hazardous Waste</i>
Cleaning materials	Fluorescent tubes
Desinfecting materials	Refrigerators
Neutralisers	Oils
Filters	Oil contaminated materials
Oils/grease	Used inks
Salts	Chemical remnants
Cooling materials	Electrical scrap
Repair and maintenance materials	Waste Water
Canteen	Amount in m ³
Office	COD
Other	BOD
Energy	Phosphates
Gas	Nitrogen
Coal	Ammonium
Fuel oil	Biogas
Fuels	Air-Emissions
District heat	CO
Renewables (Biomass, Wood)	CO ₂
Solar, Wind, Water	SO ₂
Externally produced electricity	NO _x
Internally produced electricity	Dust (not relevant)
Water	FCICHS, Nh ₄ , VOC (not relevant)
Municipal Water	Ozon-depleting substances (not relevant)
Ground water	Noise
Spring water	Maximum Noise at night
Rain/ Surface Water	Maximum Noise on site

Figure 23: Input Output framework for breweries

INPUT	PROCESS	SIDE PROCESS	OUTPUT
Malt Energy	Grinding		Dust
Brewing water Detergent Energy	Mashing		Heat
Water Energy	Purification		Spent grains Heat Waste water
Hops Energy	Preparation of wort		Heat
Water Energy	Removal of hops waste		Hops waste
Water Energy Detergent Refrigerant	Cooling of wort		Warm water
Yeast Sterile Air Water Energy Refrigerant	Fermentation		Yeast Wasted beer Carbonic acid Waste water
Water Energy Refrigerant Disinfectant	Storage		Storage dust Waste water Wasted beer CO2
Water Energy Carbonic Acid Detergent Disinfectant Auxiliary Materials	Filtration		Waste water Filtrate Auxiliary materials
Water Energy Refrigerant Detergent Disinfectant Carbonic Acid	Pressurization		Waste water CO2
Water Energy Detergent Disinfectant Bottling		Bottle and Cask cleaning	Waste water Waste paper Waste glass Sludge Heat
Lemonade Raw Materials Sugar		Lemonade production	
Water Energy Carbonic Acid Packaging	Bottling, Casking		Bottled wasted beer Casks, boxes Packaging waste Waste glass Rinsing water Residue Waste water
Department specific Inputs		Workshop, Canteen, Administration	Department specific Outputs
Fuel oil Water		Steam/Heat production	Air Emissions
Petrol	Transport and Delivery		Air Emissions

Figure 24: Process flow chart of breweries

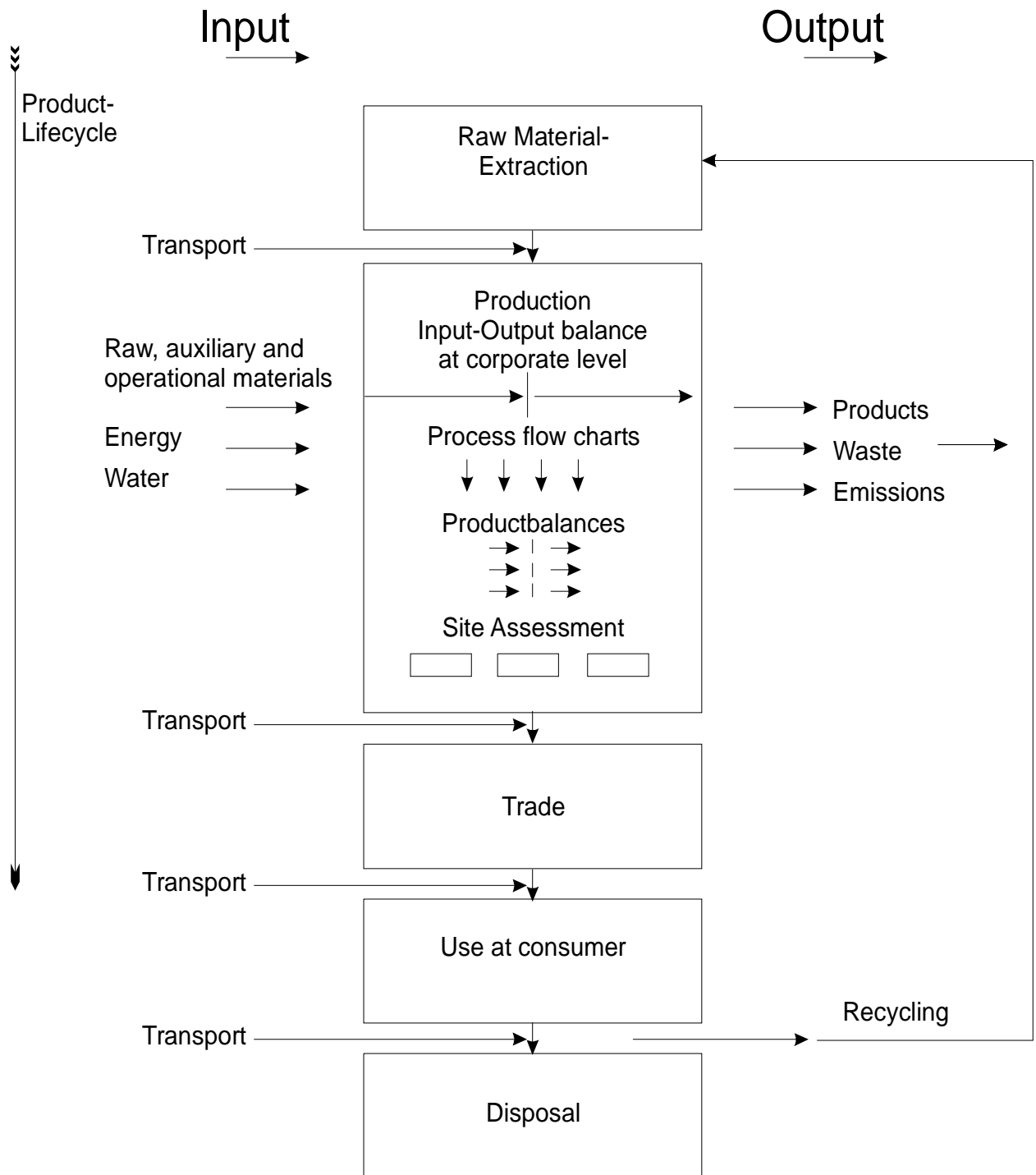

Figure 25: Product life cycle assesement

6. ONE STEP FURTHER DOWN – PROCESS FLOW CHARTS AND COST ACCOUNTING

6.1. Cost Accounting Basics

There is a continuous exchange of data and information evaluation between financial accounting, cost accounting, budgeting and statistics. Aside from this information and data exchange, cost accounting has the following main objectives:

- Identification of price floors and ceilings;
- Calculation of planned and past production costs;
- Evaluation of internal services, finished and unfinished products for sales or tax purposes;
- Improving economic efficiency;
- Providing basic data for company policy and decision-making;
- Short-term performance evaluation;
- Operating comparisons.

Cost accounting is clearly distinguished from financial accounting by its calculating procedures. Its primary objectives are realistic cost assessment, cost projections and planning, and controlling and monitoring of company processes.

When trying to assess environmental costs, one will find that not every company does cost accounting. More often, especially small and medium sized companies (SMEs), work with data from the profit and loss account. It is up to management to decide whether the company should use cost accounting, and if so, which system it should use and how it should be designed. In contrast to financial accounting, this decision is not influenced by tax and commercial law.

Important Terms:

- **Fixed Costs** are costs independent of employment and production volume, such as rent, interest on bank loans etc.
- **Variable Costs** are directly related to production volume, e.g. raw materials and production labor hours;
- **Individual Costs** are directly attributed to the corresponding cost centers (process steps) and cost carriers (products). They include at a minimum raw materials and production wages;
- **Overhead Costs** are costs that cannot be directly attributed (true overhead) or costs that are not directly attributed for reasons of economic efficiency (untrue overhead), e.g. administrative costs, insurance, advertising costs. There are a number of methods to attribute overhead to cost centers and cost carriers.
- **Calculated Costs** are used in cost accounting because they are not – or in a different form - considered in bookkeeping, but influence operating results. If these costs are not matched by expenditure in financial accounting, they are called extraordinary rates, e.g. calculated equity capital interest, calculated rent/lease, calculated management wages. If these costs are matched by an expenditure in bookkeeping, they are also called Other Costs such as calculated borrowed capital interest, calculated write-offs on the basis of replacement prices, calculated risks;
- **Costs Centers** are those parts of the company that are organized as independent clearinghouses; they should be connected to production processes. Maximum consistency between cost centers and process-oriented material flow analyses is the

prerequisite for good data. Cost centers generate costs, are responsible for costs or are attributed costs, e.g. for production and administration.

- **Cost Carriers or Objects** are products and services produced either for the market or for internal needs. By attributing types of costs to cost centers and cost carriers, production costs and sales price floors are calculated.

Since financial accounting operates on strict rules for the assessment of expenditures and revenues and calculatory assessments are not permitted. Costs and earnings are thus determined by the so-called roll-over. For this roll-over, financial accounting expenditures are excluded that, from a cost accounting standpoint, are not considered costs because they are

- ⇒ Non-operational (e.g. are not connected to the operating objective);
- ⇒ Extraordinary (e.g. are exceptionally high or rare);
- ⇒ Unrelated to the accounting period;
- ⇒ Assessed differently (e.g. they do not correspond to indicated values of the cost accounting calculation objective)

These expenditures are called neutral expenditures. Expenditures that are operational, ordinary, related to the accounting period and assessed correctly are at the same time considered costs and are called cost-identical expenditures, functional or basic costs. From this standpoint, expenditures and costs overlap. In a next step, cost-identical expenditures are complemented by calculated costs.

Cost-Category Accounting is the first phase of cost accounting and answers the questions:

- Which costs have been incurred in which amounts during the accounting period?

In cost-category accounting, costs are recorded in accordance with a cost category plan and divided into direct costs and overhead. Before this is done, a separation is made from expenditure accounting of financial accounting and / or the roll-over of costs from financial accounting. In the past, an overhead roll-over sheet was used for that purpose; today, computer programs are used.

Cost Center Accounting follows cost-category accounting and answers the question:

- Where and in which amounts have which costs been incurred during the accounting period?

For this accounting procedure, the overhead allocation sheet is used. Cost center accounting is also responsible for internal cost assignments. Finally, it determines cost estimate rates or billing rates (or surcharge rates) should they be required for cost carrier accounting based on the company operational situation.

Cost Carrier Accounting is the final phase of cost accounting and determines the production costs for each product (or service). It provides the basis for price calculation. It answers the question:

- Which types of costs have been incurred in which amounts for a certain product or service?

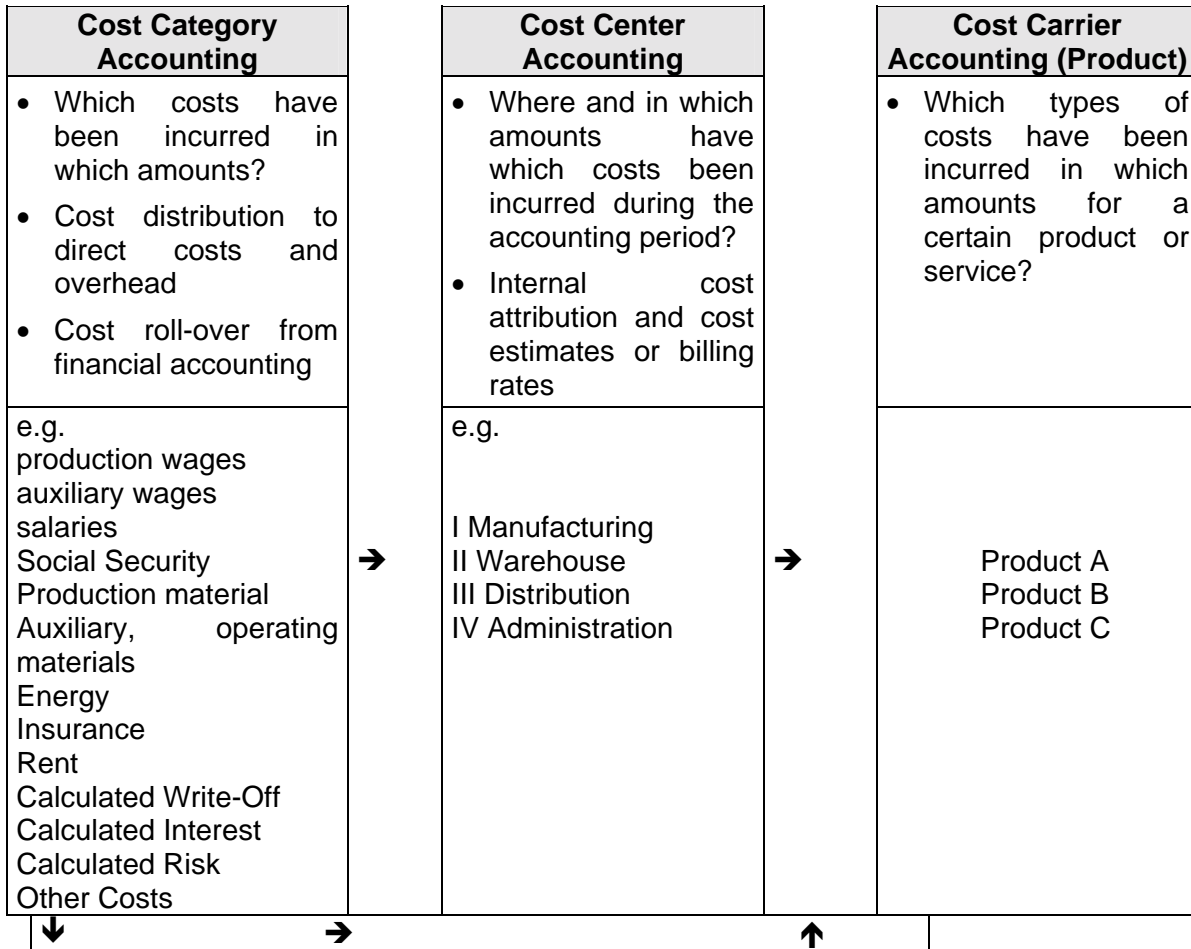

Figure 26: Relationship between Cost Category, Cost Center and Cost Carrier Accounting

(Source: Dimitroff/Jasch/Schnitzer, 1997)

Cost attribution is done in 2 steps, first from joint (environmental) cost centers like waste management and emission treatment, to the responsible cost centers in the production process and secondly from the production cost centers to the respective cost carriers/objects (Product A and B).

A simple example in figure 27 + 28 shows how overhead cost-roll over can significantly change the production costs of products.

Awareness should be paid to the fact, that changed allocation rules may lead to a redistribution of power in a company. Production lines and products which used to be profitable may suddenly have a bad performance, so the responsible line managers will tend to refuse the change, especially if they don't have the means to improve their situation.

Whenever possible, costs should be allocated to the respective cost centers and cost carriers/objects (products). Many terms are used to describe the methodologies for that purpose, such as "activity based costing", "full cost accounting", "process costing", "material flow costing".

	Product A	Product B	Example		
			Overhead	Product A	Product B
Materials by recipe/formula and stock issuing	Direct costs	Direct costs		70	70
Working hours by time records	Direct costs	Direct costs		30	30
Overhead	distribution by % product turnover				
Depreciation			50		
Rent			10		
Energy			5		
Communication			10		
Administration			25		
Top management's salary			10		
Waste & Emission Treatment			10		
Total Overhead			120	60	60
Total product costs				160	160

Figure 27: Environmental Costs hidden in Overhead Accounts

	Product A	Product B	Example		
			Overhead	Product A	Product B
Materials by recipe/formula and stock issuing	Direct costs	Direct costs		70	70
Working hours by time records	Direct costs	Direct costs		30	30
Energy	Attribution to cost centers and products by actual process flows		1	1	3
Waste and Emission treatment			1	3	6
Depreciation			7	13	30
Overhead	distribution by % product turnover				
Rent			10		
Communication			10		
Administration			25		
Top management's salary			10		
Total Overhead			64	32	32
Total product costs				149	171

Figure 28: Environmental Costs attributed to Cost Centers and Products

6.2. Process Flow Charts

The next step after environmental cost assessment and material flow balances on a corporate level is to allocate the data from the system boundary of the company fence to internal processes.

Process flow charts, which trace the inputs and outputs of material flows on a technical process level, give insights into company-specific processes and allow the determination of losses, leakages and waste streams at the originating source. This requires a detailed examination of individual steps in production - again in the form of an input-output analysis, but sometimes linked to technical Sankey diagrams. The process flow charts combine technical information with cost accounting data. They are not done on a yearly basis but for a specified production unit, machinery or cost center. In total, they should aggregate to the yearly amount.

This level of material flow analysis will be in the responsibility of technicians, but the data gathered should be cross-checked to ensure consistency with the cost accounting system. Usually a harmonization of technical data with data from financial bookkeeping is not undertaken due to lack of inter-departmental communication. Experience has shown that such a consistency check provides great optimization potentials, and has thus become a major tool in environmental accounting. Therefore it is desirable for the technical and financial bookkeeping to be conducted in a compatible way.

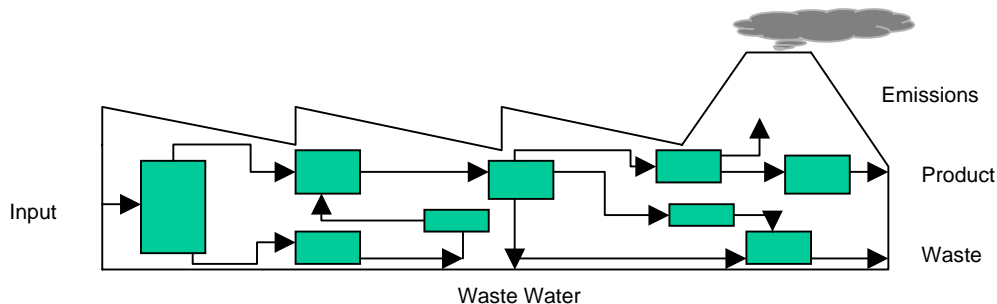

Figure 29: Process flow charts: Opening of the Black Box

Splitting up the corporate flows into cost centers, or even down to specific production equipment allows for more detailed investigation of technical improvement options, but also for tracing the sources of costs. Special attention should be drawn to the quantitative recording of materials on a consistent kilogram basis. The key questions are:

- What cost center have processed how much of the materials?
- Can material input be further divided into production lines or specific equipment?
- How large were the resulting emissions, scrap and waste, preferably recorded separately for each cost center, production line and machinery?

The process level is the main focus for pollution prevention projects. Data on the process level is also necessary for further analysis by products. It is crucial that the system boundaries for financial calculation by cost centers and for technical monitoring can be related to each other. To ensure consistency between data from cost centers and process flow charts, the methods of activity based costing and of flow cost accounting have been developed.

6.3. Activity based costing

This section discusses activity-based costing of pollution prevention. The focus of this approach deals with correct allocation of costs to products, by reducing the amount of costs hidden in overhead cost categories. Applying this approach can improve economic performance as a consequence of improved environmental protection⁸. Moreover, ignoring this approach could distort product pricing and investment decisions.

The example in Figure 30 shows that costs of “joint” environmental cost centers, such as incinerators, waste water treatment plants, etc., should be differentiated from other overhead costs. The manufacturer has three production steps that all produce waste. The entire waste is treated in a shared incinerator on the production site. The costs of incinerating the waste from current production are \$800; the remaining overhead costs for general administration, salaries of top management, etc. are \$9,000.

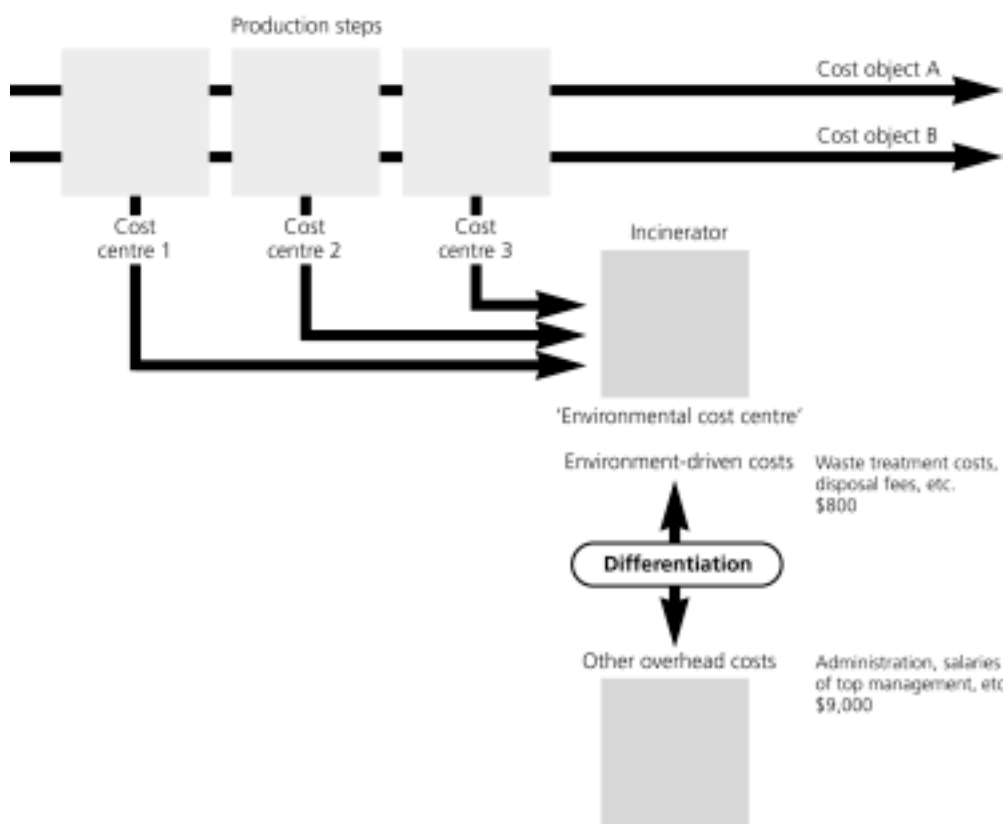

Figure 30: Tracking and tracing of environmental related costs

(Source: Schaltegger, Müller, 1997)

Internal environmental costs are often treated as overhead costs and divided equally between all cost drivers. A common example is that the costs of treating toxic waste of a product are included in the general overhead costs, and the overhead is allocated in equal parts to all products.

However, ‘dirty’ products cause more emissions and require more clean-up facilities than ‘clean’ products. Equal allocation of those costs therefore subsidizes environmentally more

⁸ see Schaltegger et al., the description of ABC in the following is taken from Schaltegger S., Müller K., 1997

harmful products. The clean products, on the other hand, are 'penalized' by this allocation rule as they bear costs that they did not cause.

Many companies simply include all environmental protection costs in their general overhead costs, together with the top management salaries, advertising costs and all other costs that were not traced back to individual production processes. At a time, when environmental compliance costs were marginal and profits high, this might have been reasonable. But, with increased environmental awareness, strong competition and the need to improve production efficiency, especially with regard to material efficiency, the cost of tracking and tracing material flows throughout the company are by far outweighed by the improvement potentials identified and realized.

A simple example in Figure 31 illustrates how equal allocation can lead to suboptimal management decisions. Two processes are compared: process A is 'clean' and does not cause any environment-driven costs for the company, while process B causes \$50 of extra costs because it is environmentally harmful. If these costs are assigned to general overheads and allocated equally, both processes appear to create a profit of \$75. (If \$50 is allocated to overhead, \$25 will implicitly be allocated to each process. This leads to a profit of \$75 [\$200-\$100-\$25]). In reality, however, process A has created a profit of \$100, while process B only has only contributed \$50 to the company's profit.

	'Clean' process A	'Dirty' process B
Revenues	\$200	\$200
Production costs	\$100	\$100
Environmental costs	\$0	\$50
True profit	\$100	\$50
If environmental costs are overhead	\$25	\$25
Then the book profit is	\$75	\$75
Which is incorrect by	-25%	+33%

Figure 31: Example of correct and incorrect cost allocation

(Source: Schaltegger, Müller, 1997)

Suboptimal management decisions materially influence the pricing of products. The cross-subsidized dirty products are sold too cheaply whereas the environmentally less harmful products are sold too expensively. In consequence, market share is lost in more sustainable fields of activity and at the same time the company's item is enhanced in fields with higher risk and poor business future.

Whenever possible, environment-driven costs should be allocated directly to the activity that causes the costs and to the respective cost centers and cost drivers. Consequently, the costs of treating, for example, the toxic waste arising from a product should directly and exclusively be allocated to that product.

Many terms are used to describe this correct allocation procedure, such as 'environmentally-enlightened cost accounting', 'full-cost accounting' or 'activity-based costing' (ABC). ABC, activity based costing, "is a product costing system, ..that allocates (costs typically allocated to overhead in proportion to the activities associated with a product or product family"⁹.

⁹ Spitzer, Calculating the benefits of Pollution Prevention, p.6)

ABC represents a method of managerial cost accounting that allocates all internal costs to the cost centers and cost drivers on the basis of the activities that caused the costs. The activity-based costs of each product are calculated by adding the appropriate share of joint fixed and the joint variable costs to the direct costs of production. The strength of ABC is that it enhances the understanding of the business processes associated with each product. It reveals where value is added and where value is destroyed.

The example in Figure 32 illustrates the method of ABC. It shows two steps of allocation: first, from joint environmental cost centers to the 'responsible' cost centers (i.e. production processes); and, second, from the production cost centers to the respective cost drivers (i.e. products A and B).

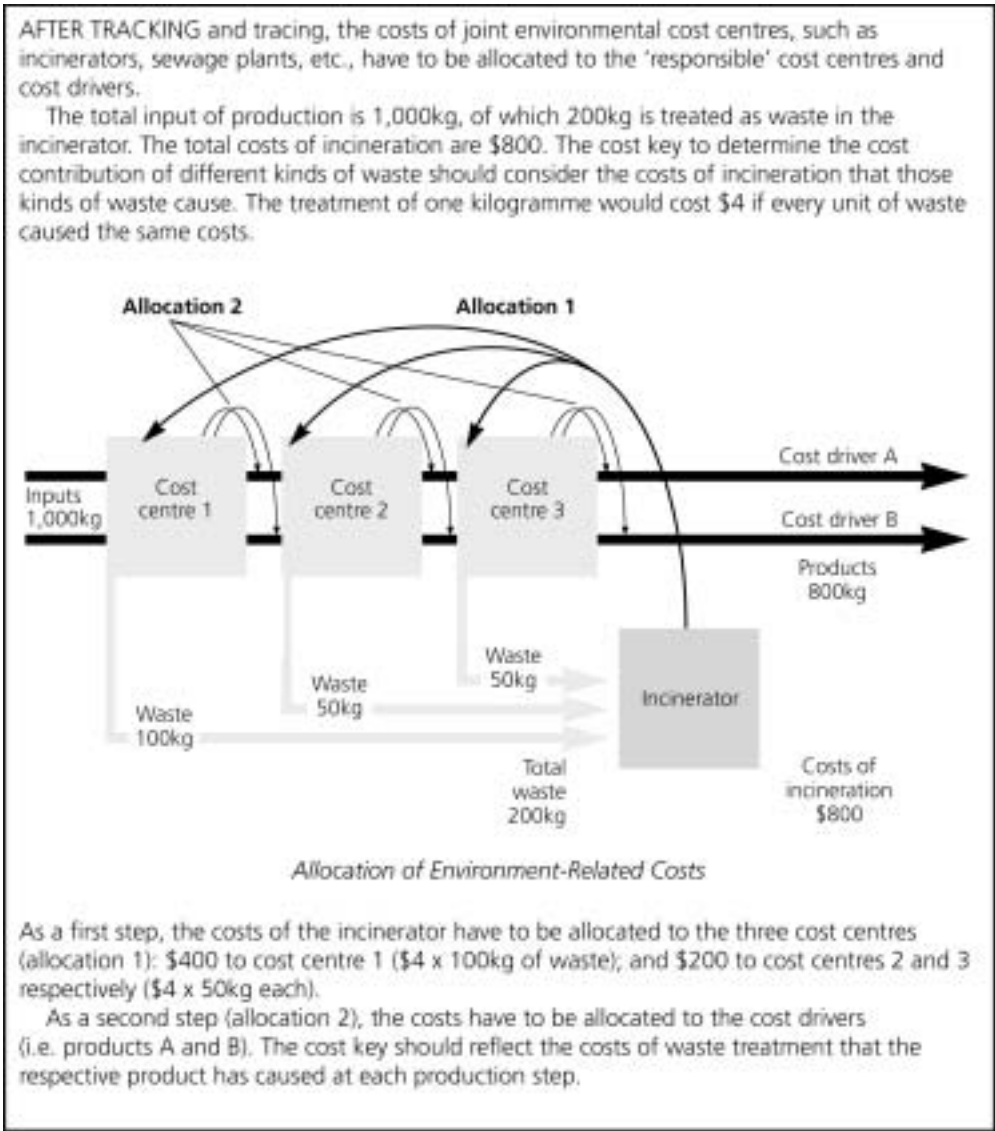

Figure 32: Twofold allocation of environment related costs

(Source: Schaltegger, Müller, 1997)

Today, it is substantially misleading to include all environment-related costs in general overhead costs; nevertheless, some remain as overheads, such as those costs clearly related to general overhead activities (e.g. new insulation of the head-office building). Also, costs of past production that are clearly related to strategic management decisions for the whole

company might qualify as general overhead costs (e.g. liability costs for products that have been phased out).

At present, even in some advanced management accounting systems, only the visible (direct) costs of environmental cost centers are directly allocated to production cost centers and cost drivers. However, additional costs can be environment-driven even though they do not directly relate to a joint environmental cost center (e.g. an incinerator). Yet some indirect costs could be saved if less waste was created. Waste occupies manufacturing capacities, requires labor, increases administration, and so on. If no waste was produced, the equipment would not depreciate as quickly, and less salaries would have to be paid.

For instance, in the example in Figure 32, 200kg of the 1,000kg of inputs were purchased only to be emitted without creating any value. Thus, the related waste has caused a 20% higher purchasing cost, higher costs of depreciation and administration, etc. Therefore, a third allocation step is necessary. As shown in Figure 33, this third allocation step can motivate management to realize huge efficiency gains by improving the environmental record at the same time!

The choice of an accurate allocation key is crucial for obtaining correct information for cost accounting. It is important that the chosen allocation key is closely linked with actual, environment-related costs. In practice, the following four allocation keys are considered for environmental issues:

- Volume of emissions or waste treated
- Toxicity of emissions or waste treated
- Environmental impact added (volume is different to impact per unit of volume) of the emissions
- Relative costs of treating different kinds of waste or emissions

One possibility is to allocate the environment-driven costs based on the volume of waste caused by each cost driver (e.g. volume treated by hour, waste/kg of output, and emissions/working hour of equipment). This is a rather arbitrary key in cases where the capital costs (interest and depreciation of construction costs (capital assets)) as well as the variable costs are not related to the total volume treated. Due to higher safety and technological requirements, the construction costs and the variable costs often increase substantially with a higher degree of toxicity of the waste treated. In many cases, these additional costs are due only to a small percentage of the waste. Thus, the costs of a treatment or prevention facility are often not clearly related to the overall volume treated, but rather to the relative cleaning performance required.

Another possibility is to allocate costs according to the potential environmental impact added of the treated emissions. The environmental impact is calculated by multiplying the volume of waste by the toxicity of the emissions. However, this allocation key too is often inappropriate, as the costs of treatment do not always relate to the environmental impact added.

Thus the choice of allocation key must be adapted to the specific situation, and the costs caused by the different kinds of waste and emissions treated should be assessed directly. Sometimes a volume-related allocation key best reflects the costs caused, while in other cases a key based on environmental impact is appropriate. The appropriate allocation key depends on the variety and the kind of waste treated or emissions prevented. Also the time of occurrence may be relevant (past, current or future costs).

THIS EXAMPLE illustrates the third step of allocation on the basis of the example used in Figure 4. 1,000kg of inputs has been purchased to create 800kg of products. Of the 200kg of waste, 100kg are created in step 1, and 50kg each in steps 2 and 3.

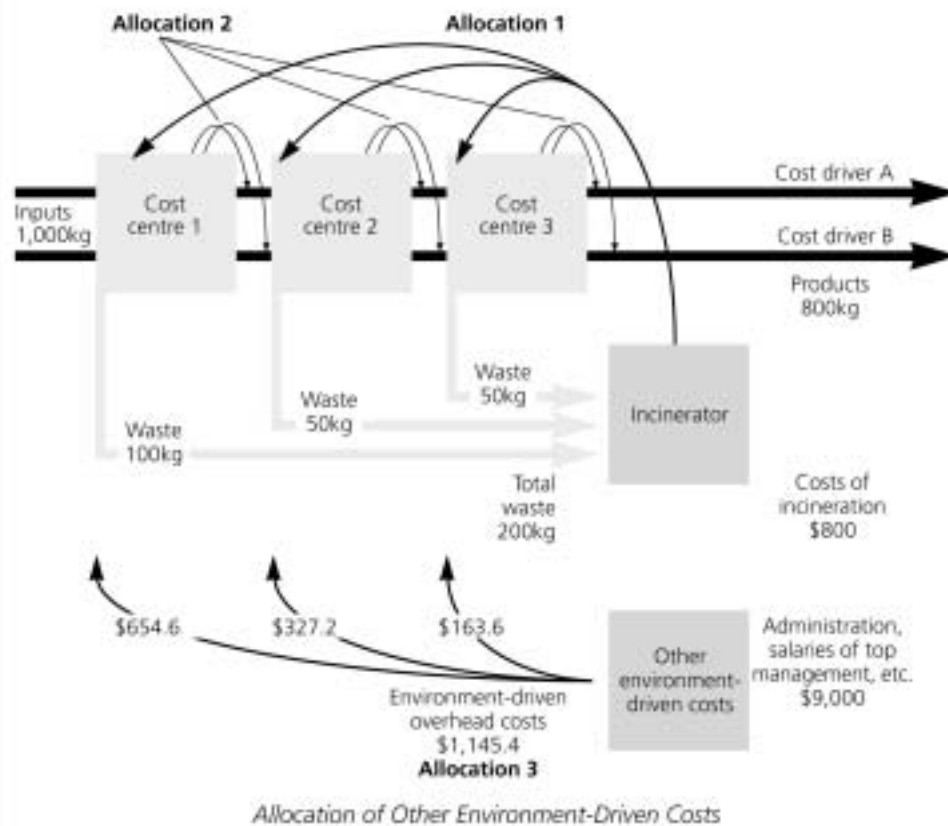

With the first and second allocation steps, the costs of the environmental cost centre (\$800 for incineration) have been traced, tracked and allocated to the cost centres and drivers. However, environment-driven costs are actually much higher. Some inputs were purchased 'just to be thrown away', without having created any value. Therefore, the management should also account for other environment-driven costs, such as increased depreciation, higher costs for staff, etc. which are not directly related to joint environmental cost centres but which nevertheless vary with the amount of throughput. To take these environment-driven costs into consideration, a third allocation step is necessary.

In the case presented, it is assumed that the overhead costs of \$9,000 are variable, the mass of the waste is an adequate allocation key and that the overhead costs per kilogramme are the same in all three cost centres.

The processed kilogrammes of material are 1,000kg in cost centre 1, and 900kg and 850kg in cost centres 2 and 3 respectively (see table below). Possible allocation keys for the total overhead costs are 36.36% (cost centre 1), 32.73% (cost centre 2) and 30.91% (cost centre 3) if the total amount of processed material (e.g. 1,000kg of 2,750kg for cost centre 1) is taken as the allocation key. Thus, the total overhead costs per cost centre are \$3,273 (cost centre 1), \$2,945 (cost centre 2) and \$2,782 (cost centre 3).

Figure 33: Third allocation step
(Source: Schaltegger, Müller, 1997)

6.4. Flow Cost Accounting

6.4.1. What is the Purpose of Flow Cost Accounting?

Flow cost accounting is an essential instrument in a new management approach known as **flow management**¹⁰ and goes beyond assessment of environmental costs. The aim of flow management is to organize production end-to-end in terms of flows of materials and information – all structured in an efficient, objective-oriented manner. Energy flows can be thought of in the same way as material flows, especially since it is often in material form (in the full sense of the word, e.g. coal, oil, gas) that energy first enters a company. Therefore the word “material“ is used as generic for materials and energy.

End-to-end analysis with the principle of flow management involves not only the company's flows of materials but also its organizational makeup (i.e. structural organization, procedural organization) and the configuration of its various integrated information systems (i.e. materials management, production planning and control, financial accounting, cost accounting, and controlling).

Flow management focuses on **the flow of materials is center-stage among the company's various organizational functions** - and the company can be defined as a material flow system; (see figure 34). This includes, on the one hand, the classical material flows along the value-added chain, from incoming goods, by way of various processing stages, through to product distribution to the customer. It also includes, on the other hand, all the material losses incurred at various stages along the logistics chain (e.g. rejects, scraps, chippings, destruction of expired items or damaged goods), which then leave the company as environmentally and economically undesirable residue (solid waste, effluent, emissions). The corporate material flow balance is divided into various production steps and cost centers. For a more detailed material flow model that has been designed for a project in the pharmaceutical industry please refer to the appendix.

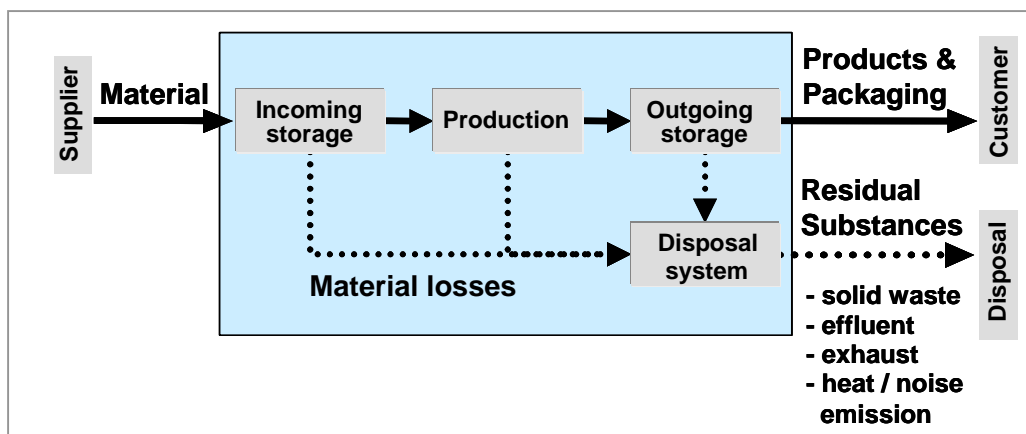

Figure 34: The company - seen as a material flow system

(Source: IMU Augsburg)

¹⁰ The description of flow cost accounting has been provided by IMU Augsburg. See also Strobel M., 2000, LfU 2000

Flow cost accounting performs an important function within flow management, namely that of quantifying the elements in the material flow system and improving in-house information flows, as well as revealing **points of departure for economically and ecologically oriented modifications to the flows of materials**. In quantifying the material flow system, the company creates a database containing quantities, values, and costs, consistent throughout. The database shows those quantities (in physical units like numbers, kg, m³, KWh etc.), values (= physical quantity x input price) and costs that refer to the material flows (e.g. material costs, inventory values, and waste volumes) and to all the other costs incurred by the company in maintaining the material flow system (e.g. personnel costs, depreciation).

The focus of flow cost accounting is not to determine the share of total environmental costs, but to focus on material flows for assessment of total costs of production. Flow cost accounting is thus an improvement on existing accounting approaches - in two respects : economic and ecological.

1. Seen from the **economic perspective**, flow cost accounting is based on actual material costs. These, in manufacturing companies, often constitute by far the largest costs. By comparison, the system costs, i.e. those costs incurred in maintaining the system, comprising mainly personnel costs and depreciation, are much lower. And waste disposal costs are in general relatively insignificant. Usually the costs concerned purely with disposal (e.g. waste disposal fees, external waste transport) account for between 1% - 2% of the total costs for a manufacturing company.

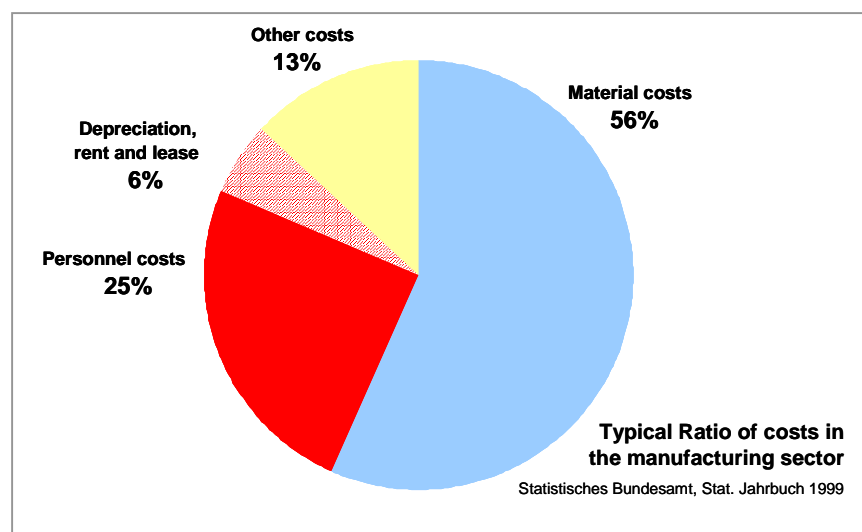

Figure 35: Typical proportion of costs in the manufacturing industry

(Source: IMU Augsburg)

This average cost structure in German manufacturing companies corresponds largely with the results of an American study conducted by „Business Week“ magazine (22th march 1993), which puts the share of material costs in US companies at 50 to 80 %.

Conventional accounting approaches are not able to provide sufficiently precise data regarding the costs of materials. With such inconsistent and incomplete data and the myriad of data islands, a company will hardly be able to track the point of internal material consumption and pinpoint exact flows and whereabouts of every single material through the material flow system.

Flow cost accounting eliminates this information gap by linking quantitative physical and monetary data to the material flows. The course taken by materials entering a company becomes transparent - and informed decisions can be taken regarding which material with which values go into the product as added value and which materials with which values leave the company unproductively as waste. In companies participating in pilot projects, this flow-oriented transparency often led to new ways of designing products that reduced materials intake and to new measures for increasing overall efficiency (by reduction of rejects, scrap, damaged products etc.).

2. Seen from the **ecological perspective**, flow cost accounting systematically focuses cost cutting on attempts to reduce the quantities of materials and energy used, thus leading to positive ecological effects (avoidance of waste, effluent, and emissions) and to environmental benefits. Flow cost accounting is thus an important instrument in implementing an integrated environmental management system and in raising ecological efficiency. Indeed, the environment will benefit from the ecological effects of flow cost accounting - even in cases where this may not be the company's conscious intention.

Production-integrated measures to relieve stress on the environment and to cut costs can only be systematically implemented if the material and energy flows – in terms of quantities and the associated values and costs - are transparent end-to-end.

6.4.2. The basic idea of flow cost accounting

The instrument of flow cost accounting ¹¹ shifts a company's in-house material flows into the center of cost analysis and attempts to make these flows transparent end-to-end in terms of their effects on costs. This transparency can contribute to clarifying the complex relationships of effects operating within the material flow system and thus create a comprehensive database for evaluating measures for improvement and realizing saving potentials.

Flow cost accounting may reveal that a measure designed to raise efficiency in a production system leads not only to lower costs in material consumption but also to lower costs in materials handling and waste disposal. Changing to a new colorant for example may lead not only to different absorption levels but also to reduced costs for water treatment.

In order to comprehensively assess the cost effects of planned measures and reveal potential savings, the effect of each measure on the whole material flow system must be calculated and evaluated. Previously the evaluation of measures has often been inadequate. This leads, firstly, to environmentally damaging and uneconomical measures being implemented and, secondly, to numerous environmentally positive and cost-cutting measures being dismissed or overlooked because, with previous conventional assessments, the benefits are underestimated.

In flow cost accounting, in order to attain this transparency, the **values and costs of the material flows** are divided up into the following categories :

1. Material,
2. System, and
3. delivery and disposal.

¹¹ See also Wagner, B. / Strobel (1999), Hessisches Ministerium für Wirtschaft (1999), Strobel (2000)

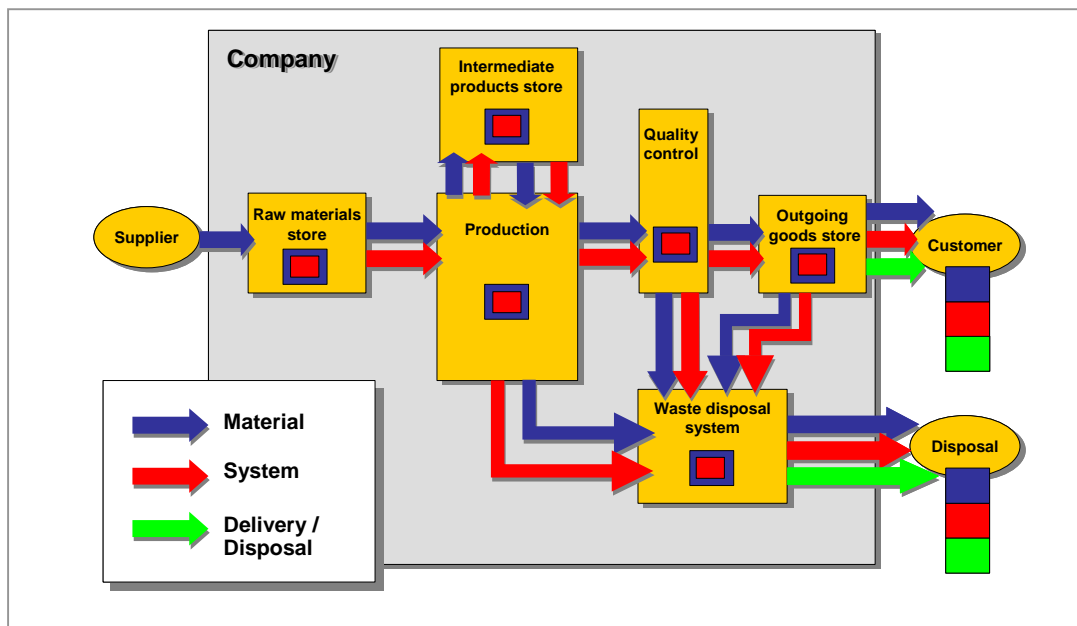

Figure 36: The Basic Idea of Flow Cost Accounting

(Source: IMU Augsburg)

Material values and costs

For the purposes of calculating the **material values and costs**, one needs detailed knowledge of the physical quantities of materials involved in the various flows and inventories. Usually, the existing materials management systems and production planning systems provide (at least for the product materials) a comprehensive database which has merely to be adapted and expanded.

Based on these flow quantities and inventories, one can proceed to make valuations in terms of prices and thus obtain the material values of these flows and inventories. Material costs can then be determined by defining which material flows are cost-relevant.

The possibility of reporting material purchase values and costs at later stages for material flows and material inventories separately throughout the company is also known as “material value orientation”¹². Material value orientation is the core of flow cost accounting. The transparency of knowing values and costs for materials already creates, at acceptable expense and effort, new access to the largest costs share.

System values and costs

For the purposes of assigning the **system values and costs**, material movements have to be treated as cost drivers. „System“ costs by definition are those costs that are incurred in the course of in-house handling of the material flows (e.g. personnel costs, depreciation). System costs are incurred by the company in efforts to ensure that material movements can be made in the desired form. System costs allocated to material flows are defined as „system values“. Whether these flows are raw materials, intermediate or semi-finished goods, or material

¹² In the US such approaches are termed „Material only Costing“ (MOC), see e.g. Coopers & Lybrand (1997), Lucnet Technologies (1998).

losses, each in-house material flow can be seen as a cost carrier for allocating system costs systematically according to cause. Under this heading come all costs which are incurred inside the company for the purposes of maintaining and supporting material throughput, e.g. personnel costs or depreciation.

System costs are allocated to the outgoing product flows (e.g. from the “production” cost center) and then passed on as system values to the subsequent flows and inventories.

Delivery or disposal costs

For those flows leaving the company specific **delivery or disposal costs** must also be allocated. Such outgoing delivery and final disposal costs include payments to external third parties; thus these are by definition not part of system costs. Delivery and disposal costs include all costs incurred in ensuring that material leaves the company, i.e. not only transport costs for products but in particular, the external costs for disposing of waste and the fees for waste water and effluent control.

The **result of flow cost accounting** is end-to-end transparency showing quantities, values, and costs of material flows, separated into the three categories “material”, “system”, and “delivery and disposal”. One decisive point in flow cost accounting is that the above-mentioned three categories of values and costs are separately recorded and managed end-to-end both for the material flows and for the material inventories. Practical experience shows that this can bring about fundamental changes in a company’s way of seeing things, of making decisions, and of acting, whereas in traditional cost accounting, after the first processing stage when the intermediate product is calculated, material costs and system costs are already mixed together. It thus very soon becomes impossible to list costs and values separately according to the three categories either for material movements or for inventories.

6.4.3. The Method – an overview

Flow cost accounting is a far-reaching computerized accounting approach which is made up of numerous individual steps and which has to deal with massive amounts of data. Flow cost accounting can therefore only be performed with the appropriate computer support.¹³ Experience shows that a company’s existing database, material management system and production planning and control system, will usually contain the majority of the data needed. The extra effort and expense involved in implementing flow cost accounting is thus not so much the continuing acquisition of additional data but rather the system’s one-time installation.

The data flow and the sequence of flow cost accounting run from the stipulation of the necessary database by way of the accounting elements, through to the various results and report form. In the opposite direction, in response to specific demands concerning the results and report forms, adaptations regarding the accounting elements or even the database may be required.

¹³ See also Krcmar et al (2000), Dold / Enzler (1999)

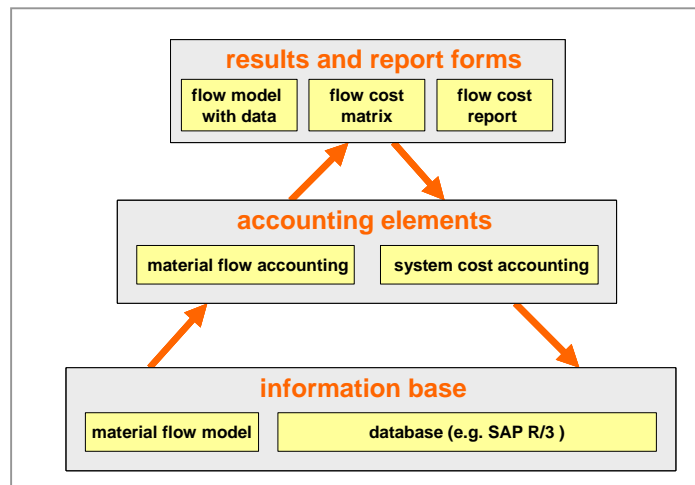

Figure 37: The components of flow cost accounting

(Source: IMU Augsburg)

The **information base** needed for flow cost accounting comprises the material flow model and the defined database.

The *material flow model* maps the structure of the material flow system.

The *database* contains the data needed to quantify the material flow model. The database refers both to material flows and inventories and also includes other relevant system data. It is used as basis for calculating the quantities, values, and costs allocated to the material flow model.

The **accounting elements** can initially be divided into material flow accounting and system cost accounting.

*Material flow accounting*¹⁴ is used to check the database with respect to its consistency and, on the basis of various calculations, to assign data to the flow model. Material flow accounting comprises the following individual elements:

- material flow quantity accounting,
- material flow value accounting, and
- material flow cost accounting.

System cost accounting is based on material flow accounting and used in a multi-stage procedure to assign system costs to the material flow model. System cost accounting comprises the following individual elements :

- system cost delimitation,
- system cost allocation, and
- system cost apportionment.¹⁵

The **results and report forms** define the way in which the data in flow cost accounting is edited and made available to staff.

The “*material flow model with data*” is the most important result form. Compared with previous accounting approaches, this shows much more information. For an exemplary material flow model with material flow values and delivery and disposal costs please refer to the Annex.

14 cf. also Strobel / Wagner, F. (1999)

15 cf. esp. Hessisches Ministerium für Wirtschaft (1999)

The “*flow cost matrix*” shows the outgoing material flows, e.g. products and packaging, and allocates material losses to the following categories: material costs, system costs, and delivery and disposal costs. The flow cost matrix represents in table form *flow cost accounting data in simplified and standardized form at a defined cross-section in the flow model*.

Typical structure of Flow costs (e.g. Pharmaceutical Industries)

Production costs (in US \$ m.)	Material costs	System costs	Delivery / Disposal costs	Total
Product	120	25	0.2	145.2
Packaging	40	25	2.5	67.5
Material loss	21.5	6.4	1.5	29.4
Total	181.5	56.9	3.9	242.3

Eminent share of Material costs !
(here: 75 % of production costs)

Considerable share of costs incurred by Material losses !
(here: > 10 % of production costs)

Figure 38: Flow cost matrix (simplified)

(Source: IMU Augsburg)

The structure of the matrix remains constant even if the material flow structure is modified. This makes it a particularly useful and meaningful form for presentation of results and reporting. The flow cost matrix can be used to show the development of a particular company site over several years or to benchmark different sites within the company. It can also be used to compare different companies in the same industry in terms of their respective flow cost structures.

The “*flow cost report*” allows, in addition, compilation of tables as an evaluation tool for particular areas of responsibility.

6.4.4. Experience and the benefits of flow cost accounting

The flow cost accounting approach has already been tried in a number of manufacturing companies in Germany of varying size and in different sectors. These trials have been a success. Benefits gained from flow cost accounting in their companies, project participants mentioned the following points¹⁶:

- Cost-reduction and environmental benefits as a result of improved material efficiency (i.e. reduced residual waste and reduced use of materials per product),
- Incentives to develop new products, technologies, and procedures based on the improved database for investment accounting,
- Enhanced quality of the information system thanks to consistency testing and the flow-oriented data system,

¹⁶ cf. Fichter / Loew / Antes (1999)

- Improvement of organizational structures and procedures
As a result of company-wide uniform reference to the material flow system,
- Inter-departmental, material-flow-related communication and coordination instead of insular fixation inside company divisions (departments, cost centers, etc.),
- Increased motivation in staff and management regarding the comprehensive structuring of material flows, and
- Focus on raising material productivity instead of reducing the workforce.

The cost cutting potentials revealed by flow cost accounting in the companies in these pilot projects, for material losses alone, represented between 1 and 5 percent of total costs. Usually, in the first year after flow cost accounting is introduced, cost cutting potentials of an average 1 to 2 percent of total costs can be identified and realized. This represents profit increases of over 20 percent.

Flow cost accounting aims to identify and analyze the entire system of material flows as cost driver. Not only the material costs, but also the system costs are allocated to material flows. Flow cost accounting can thus be seen as an approach to total cost accounting. It shows the extent to which costs can be cut by a reduced or more efficient use of materials and energy.

The increased transparency in terms of quantities, values, and costs achieved with flow cost accounting has the effect of encouraging the following :

- Development of products that require less materials,
- Development of product packaging that requires less materials, and
- Reduction of material losses (e.g. rejects, scrap, damaged products) and the resulting waste (i.e. solid waste, effluent, emissions)

7. APPLICATION EXAMPLE - ENVIRONMENTAL PERFORMANCE INDICATORS

Environmental performance indicators condense extensive environmental data into critical information that allows monitoring, target setting, tracing performance improvements, benchmarking and reporting. Several publications and pilot projects highlight their relevance for supporting environmental management systems.

Environmental performance indicators supply the environmental manager as well as top management with the required information from a great variety of environmental data. They enable decision makers to get a quick overall view of progress and of environmental protection problems still to be solved. On this basis, well-grounded targets for environmental performance improvement can be identified and quantified, which is necessary for controlling actual achievement. This link with traditional controlling systems allows monitoring of environmental risks and performance and detection of profitable improvement opportunities.

The strength of environmental performance indicators (EPIs) is, that they quantify developments in environmental protection and allow for benchmarking over time. With regular establishment and adjustment of objectives, environmental performance indicators assist in detecting in advance and in time negative trends in environmental controlling – serving as an early warning system. The comparison of environmental performance indicators within one company or externally with other companies or competitors, so-called benchmarking, offers the chance to detect weak points and identify potentials of improvement.

7.1. Definitions of ISO 14031 – Standard on Environmental Performance Evaluation

Environmental performance indicators may be divided into three categories. Depending on whether they aim at assessing environmental aspects of company activities by input/output material flow balances, activities of environmental management or the condition of the environment outside the company, operational performance indicators, management performance indicators and environmental condition indicators are distinguished. This system is based on ISO TC 207 SC4 „Environmental Performance Evaluation“ and the standard ISO 14031, which provides a helpful tool for setting up an indicator system.

Environmental performance indicators, **EPIs** are defined as follows in ISO 14031:

*„**OPI**, Operational performance indicator, that provides information about the environmental performance of an organization's operations.“*

Operational performance indicators are recommended for every company and form the basis of evaluation of environmental aspects. Examples are material, energy and water consumption, waste and emissions in total amounts and in relation to production volumes. OPIs are an important basis for internal and external communication of environmental data, e.g. in environmental statements in accordance with the EU EMAS-Regulation or in publications to inform employees.

*„**MPI**, Management performance indicator, that provides information about the management's efforts to influence an organization's environmental performance.“*

Management performance indicators indirectly measure the environmental protection efforts taken by a company and the results achieved with regard to influencing its environmental aspects. The number of environmental audits, staff training, supplier audits, cases of non-

compliance, certified sites etc. serve as examples. They provide useful information, however, not on the actual external environmental impact or internal environmental aspects. They supply internal quantifiable data on environmental management activities to Controlling but no information on environmental performance or impacts. An exclusive use of MPIs for evaluating environmental performance is therefore not recommended in ISO 14031, as they do not reveal the material environmental impacts and may even camouflage them.

„ECI, Environmental condition indicator, specific expression that provides information about the local, regional, national or global condition of the environment.“

Environmental condition indicators directly measure the quality of the environment. They are used to assess the impact of air emissions on air quality or the water quality. The environmental conditions around a company, such as water and air quality, are typically monitored by government authorities. Only if one particular company is the sole or main polluter in a region, monitoring by individual companies may be requested by law or may make sense also voluntarily, e.g. noise for airports, air quality for power stations, water quality for pulp and paper industries. Since the quality of environmental media such as air, water, soil and the impacts of human activities (e.g. overfertilization of water, reduction of biodiversity, greenhouse effect) depend on many factors (emissions of other companies, of power plants, households and traffic), the measurement and recording of ECIs are primarily performed by official institutions.

These external environmental indicators, in connection with objectives of environmental policies, assist the company's determination of priorities and objectives. Global and national indicators for the evaluation of environmental quality are mostly termed „environmental indicators“ or “environmental condition indicators” and are not referred to as “performance indicators”.

For the assessment of corporate environmental performance and impact the operational indicators, based on the material flow balance, are relevant. The other indicators, for the condition of environment and the management system, are secondary.

ISO 14031 also indicates how information conveyed through indicators can be presented. EPIs may be aggregated or weighted as appropriate to the nature of the information and its intended use. Aggregation and weighting should be done with caution to ensure verifiability, consistency, comparability and understandability.

Indicators can be presented in the following ways:

- Absolute figures, like tons of waste per year
- Relative figures, compared to another parameter. The most common denominators are production volumes, production hours, sales (turnover) and number of employees.
- Percentages or indexed, in relation to a baseline, like hazardous waste as % of total waste, or hazardous waste as % of the previous year.
- Aggregated data; of the same type, but from different sources, expressed as a combined value, such as total tons of SO₂ emissions from 5 production sites, aggregated to the corporate level.
- Weighted, data multiplied by a factor related to its significance, prior to aggregating or averaging.

7.2. General requirements for indicator systems

Environmental performance indicators (EPIs) monitor a company's effectiveness and efficiency of resource management. This applies mainly to physical resources like materials,

but can also be linked to other resources like personnel and money. Indicators are most useful and meaningful if they are

- Monitored over time,
- Comprised of 2 variables, an absolute measure and a reference measure,
- Comparable across sites and companies.

The following principles should be applied when installing an indicator system:

- **Relevance**

The indicators should adequately reflect the main environmental aspects and impacts of the organization and be selected by the people in charge of controlling, monitoring and target setting. Data should be collected only, if it is to be used.

- **Understandability**

Indicators must be clear and correspond to the user's information needs. If indicators become too complex, for example aggregating several items by complex mathematical calculations, people lose understanding of their meaning and how the indicator may be influenced. People in charge of activities with environmental impact must understand how an indicator can be influenced.

- **Target orientation**

The indicators should correspond to environmental improvement targets.

- **Consistency**

Comparable and reliable EPIs throughout a company can only be achieved by standardization of relevant environmental and financial variables. The same method must be used to calculate EPIs across a company, defining in detail the database and calculation procedure for each variable. In addition, the method for calculating EPIs should be consistent with the financial information system and indicators.

- **Comparability**

Indicators must allow comparison over time and with other units. Thus, the calculation principles, data sources and definitions for each nominator and denominator must be defined to make sure that the data-base is consistent across reporting units and time series. For comparison, establishing the same data collection principles in every period, referring to comparable intervals and measuring comparable units, is essential.

- **Balanced view**

An indicator system should measure changes in environmental impact and cover all important aspects of environmental impact. For all major categories of the material flow balance indicators should be defined. A common trap is to use only data available and base the indicator system on for example 20 indicators for waste, as this is monitored, but neglecting air and water emissions and material input, because data is not available.

- **Continuity**

Indicators become more meaningful if they are monitored by the same method over long periods. The time intervals for assessment (daily, weekly, monthly, yearly) should allow timely intervention in case of undesired developments (like break down of automatic sensors for water and material supply) and prevent outdated information. If indicators are calculated too infrequently or at too long intervals, there is little relation to current performance.

7.3. Generic indicator system

As a general outline for generic indicators that can be applied throughout all sectors, the following items should be monitored. Sector specific, more detailed indicators may be valuable, but aggregation to general categories should be possible. The indicator system should covers all major input and output categories.

	Absolute quantity	Relative quantity Eco-intensity
Production output (PO)	Kg, Liter,	
Raw material input	Kg	kg/PO
Auxiliary material	Kg	Kg/PO
Packaging	Kg	Kg/PO
Operating material	Kg	Kg/PO
Energy	KWh	kWh/PO
Water	M3/liter	m3/PO
Waste	Kg	kg/PO
Waste water	M3/liter	M3/PO
Specific pollution loads	Kg	Kg/PO
Air emissions	M3	M3/PO
Air emissions load	Kg	Kg/PO
Other denominators		
Number of employees	Number	
Turnover	Money value	
EBIT	Money value	
Production hours	Time	
Workdays	Days	
Building area	M2	
Management performance indicators		
Number of achieved objectives and targets		
Number of non compliances or degree of compliance with regulation		
Number of sites with certified environmental management systems (EMS)		
Number of sites with environmental reports		
% turnover from EMS certified sites		
% turnover of green products (e.g. organically grown versus conventional crops)		

Figure 39: Environmental Performance Indicator System

Absolute versus relative

From an ecological point of view, the absolute indicators are the most important ones because they measure the total consumption of resources and emissions of pollutants (e.g. the consumption of auxiliary material in kg or the quantity of waste water in m³). For comparison with previous years, a relation to previous production volumes or other significant reference figures is necessary. While absolute indicators describe the total environmental burden, relative indicators allow monitoring of efficiency improvements. Absolute and relative indicators are the two sides of a coin and are both useful. The implications of relative indicators cannot be judged without the absolute data base and vice versa.

In order to compare company units or companies, it is important, to look at absolute indicators in relation to relevant reference units (e.g. annual production quantity, number of employees or machine operation times).

Here are some examples:

Efficiency of auxiliary material = $\frac{\text{Input of auxiliary material in kg}}{\text{Produced quantity in kg}}$

Water consumption per staff member per day = $\frac{\text{Water consumption in liters}}{\text{Number of employees x work days}}$

Relative indicators represent the environmental performance of a company in relation to its size, to the production output or to the number of employees. From an ecological point of view the absolute figures of the material flow balance are more important. From the point of view of monitoring and benchmarking the relative figures have priority. Absolute indicators show the extent of environmental impact, relative indicators depict whether or not environmental measures were successful.

System boundaries

Indicators may be derived from data for the company, specific sites, departments and further down to cost centers and production processes. Each decision maker requires information for the system boundaries of his or her scope of responsibility. Thus, caution must be given to aggregation without double counting. Data on different system boundaries serves different purposes. Daily, weekly or monthly monitoring of process emissions works as an early warning system against spills and leakages and as an information source for improvement potentials, while data on the company and corporate level are more important for target setting and environmental reporting.

Environmental performance indicators may thus refer to different system boundaries, from data for the entire corporation, on different plants or sites, to individual processes or departments. The most common are:

- **Corporate indicators**
- **Site indicators**
- **Process indicators**

Indicators derived from the lower organizational level (**departments, processes, cost centers**) may be suitable primarily as a monitoring instrument for the respective departments. Assessments should be at shorter time intervals, e.g. quarterly, monthly or weekly, in order to determine weak points and to take corrective measures in time. The main inputs of raw and auxiliary materials, and energy as well as the major sources of emissions should be monitored on a process level.

Site and corporate indicators serve as general performance information for management over a longer period of time and for annual reporting for the management review. Site indicators may also be used for assessing environmental impacts in environmental statements in accordance with the EU EMAS regulations. Corporate environmental reports include aggregated indicators on a corporate level.

7.4. The problem of finding a meaningful denominator

Where production output (PO) from the material flow balance doesn't provide a meaningful indicator or is not available, or in addition to this denominator, other variables can be used. Number of employees is a reference often used especially in the service sector.

The following **environmental performance indicator matrix** shows in what way absolute indicators in combination with meaningful reference units may be used to obtain useful relative

indicators. The longitudinal axis provides examples of absolute indicators (basic data from the material flow balance), which may be related to the relevant reference units of the horizontal axis. A check mark „✓“ indicates useful combinations, the choice among which will depend on the business sector. In addition to the main categories of the input-output analysis, the matrix also includes environmental management performance indicators. Depending on the production range of a company, other variables may also be useful.

	Production volume per site or line	Cost Centre	Machine time	Material Use	Energy Use	Employees	Working days	Shifts/ Working hours	Site area	Revenue	Production costs
Material Input	✓	✓	✓					✓		✓	✓
Packaging	✓	✓	✓	✓							✓
Energy Input	✓	✓	✓				✓				
Water Input	✓		✓			✓	✓				
Detergents	✓	✓	✓			✓			✓		
Waste	✓	✓		✓		✓		✓			
Waste water		✓			✓	✓					
Emissions	✓	✓	✓			✓					
Transport						✓	✓				
Accidents						✓		✓			
Complaints							✓	✓			
Environm. Training							✓				
Environm. Costs										✓	✓

Figure 40: Environmental performance indicator matrix

(Source: Jasch, Rauberger, Hrsg.: BMUJF, 1998)

The essential task in deriving relative indicators is the selection of reference units. They must be precisely defined and logically related to the basic indicator. In practice, this question often arises in case of production-related indicators for efficiency evaluations, which show the relation between resource input and production output.

Whenever possible, the production output derived from the input-output balance should be expressed in kilograms and tons. Only in case of similar products does it make sense to use the number of products as the unit. In case of a great variety of products, however, it may become difficult to relate them to a common production basis in kg or units. An alternative would be to relate resource input or emissions to other reference units such as cost of production or turnover. In practice, however, shifts in turnover between production units with different environmental impacts may have a distorting effect on the results.

Since the translation of environmental protection into cost-related figures is becoming increasingly important, EPIs may also be expressed in cost-related values (environmental cost indicators). In practice, this is important in two ways:

- It often happens that in the initial phase of determination of environmental performance, data related to volume and weight are not readily available; the accounting department, however, may have data on related expenditures. If e.g. in energy management there are no data available on the total input in kWh, total energy expenditure could be used instead of energy input for establishing energy indicators. Instead of the indicator „energy input in kWh per production output in tons“ the indicator „energy expenditure in \$ per cost of production in \$“ may be used.
- A further advantage of cost-related environmental performance indicators is that environmental issues are thereby „translated“ into costs and savings - i.e. management's language. An executive may hardly be able to imagine which effect 450 cubic meters of hazardous waste have on profit and whether it is worthwhile to conduct a waste prevention study. If the same amount is expressed in waste disposal costs of \$ 200.000.- the issue may be clearer. The data on waste disposal expenditures available at accounting departments mostly derive from the waste disposal fees. By adding indirect waste disposal costs (storage, transportation, personnel and purchasing expenditures for the materials to be disposed) to the waste disposal fees, opportunities for cost-effective environmental protection measures may be identified.

For data collection it is important to make a clear distinction between basic data and possible reference units. Often the product quantity sold within one year differs from the quantity produced in that period (e.g. due to sales from stock) or components are purchased from an outside manufacturer, which do not cause environmental impact at the company assembling the final product. In a multi-stage production process restocking or destocking of inventory may result in changes of the production output. As a consequence, relative environmental performance indicators may lose their significance if input of resources or emissions in one year are related to the production of other periods of time. In case of changes in stock, the input and emissions take place in another period. For this reason, it may be useful to relate the production to the quantity produced in the most important stages of production instead of basic output and sales figures.

For the environmental performance indicators such as

- Energy input in kWh/kg of production
- Water input in l/kg of production
- Waste categories produced in kg/kg of production

the resource input and emissions of one period should relate to the goods produced in that period. In practice, neither the quantity of products sold nor the addition of finished goods to stock are suitable as reference units, as they include internal changes of stock of previous periods and purchased semi-finished and finished products.

For this reason, it is better to use the total output of manufacturing stages as a reference unit. If it proves to be impossible to allocate the input and emissions to a specific main source or cause, the reference variable should be calculated as a (weighted) average of the required production stages.

For personnel-related inputs (e.g. copying paper) or emissions, it is usually appropriate to use the number of employees as a reference unit, particularly in service and administrative businesses (banks, government agencies, insurance companies). Again, care needs to be taken to use uniform definitions as to how the reference units are determined (part-time staff, apprentices, holidays, shift work, etc.). This is important for internal comparisons over time and for comparison of indicators between sites.

7.4.1. Specific consumption/ Eco-intensity

Eco-intensity is defined as material input in kg (absolute indicator) in relation to output in product and/or service units in kg (hectoliter, respectively), eg. water input per hectoliter of beer production. Often the total output in kilograms is not a meaningful reference unit due to a wide range of different products; in this case indicators for certain products and/or product groups may be calculated.

$$\text{Spec. energy input} = \frac{\text{Energy input in kWh}}{\text{Production output in kg}} = \frac{1,423,271 \text{ kWh}}{371,988 \text{ kg}} = 3.83 \text{ kWh/kg}$$

Generic eco-intensity indicators for most sectors are:

- Raw material input in tons/product quantity in tons
- Energy input in kWh/product quantity in tons
- Water input in m³/product quantity in tons
- Waste production in tons/product quantity in tons
- CO₂ emissions in tons/product quantity in tons
- SO₂ emissions in tons/product quantity in tons
- NO_x emissions in tons/product quantity in tons
- VOC emissions in tons/ product quantity in tons
- Waste water quantity in m³/ product quantity in tons

Other specific consumption indicators could be input of copying paper per staff member, use of cleaning agents per square meter, or reject rate of a machine per hour of operation.

7.4.2. Share percentage

Share percentages are the ratio of a sub-group to the total. A common way of presenting indicators is in relation to a baseline such as share of hazardous, municipal, and recycling waste as % of total waste volume.

$$\text{Recycling rate} = \frac{\text{Quantity of recycled waste in t}}{\text{Quantity of total waste in t}} = \frac{3,461 \text{ t}}{4,709 \text{ t}} = 73.5\%$$

Another example would be the share of different energy carriers in the total energy input in %, or the share of packing material weight to the total shipped product weight in %.

Generic indicators for shares are:

- Share of different materials in a product in %
- Share of materials for product and packing in %
- Share of products complying with defined environmental criteria (e.g. ecolabelled, organic) in % of total products
- Share of renewable energy sources in % of total energy input
- Share of ton kilometers on railway/ship/truck in %
- Share of passenger kilometers of business trips by on means of transport in %
- Share of hazardous waste in relation to total waste production in %)
- Recycling rate (share of recycled waste in relation to total waste production in %)

Share percentage of environmental costs

From the total environmental cost roll over scheme, the shares of costs by media and by cost item can be calculated. In the pulp and paper industry in Austria, for example, water management accounts for up to 50 % of all environmental cost, with waste and air/climate accounting for about 30 and 20 %. But wasted material input is by far the dominant cost factor,

accounting for about 80 % when calculated by cost items (material purchase and processing costs). For other sectors and regions, these shares will vary. Figure 41 shows an example from the pulp and paper industry.

Environmental media										
Environmental categories	cost/expenditure	Air + Climate	Waste Water	Waste	Soil + Ground	Noise and Vibration	Biodiversity + Landscape	Radiation	Other	Total
1. Waste and Emission treatment		1	11	5	0	0	0	0	0	17
2. Prevention and environmental management		1	1	1	0	0	0	0	2	5
3. Material Purchase Value of non-product output		14	34	20	0	0	0	0	0	68
4. Processing Costs of non-product output		2	6	10	0	0	0	0	0	12
Σ Net Environmental Expenditure		18	52	36	0	0	0	0		
5. Environmental Revenues			- 2	- 6	0	0	0	0		- 8
Σ Total Environmental Expenditure		18	50	30	0	0	0	0	2	100

Figure 41: Share of environmental costs

Total annual investments

Total environmental annual investments, separated into end-of-pipe treatment, integrated pollution prevention technologies (environmental share) and other investments, should also be recorded and disclosed in environmental accounts. Sometimes, also the statistical agencies and environmental protection agencies ask for this information.

7.4.3. Eco-efficiency Ratios

OPIs are sometimes linked not only to physical units such as kilograms, kWh or hectoliters, but also to monetary variables like turnover and profit. Financial indicators are measured in terms of monetary units.

The World Business Council for Sustainable Development, WBCSD, defines eco-efficiency as an indicator that relates “product or service value” in terms of turnover or profit to “environmental influence” in terms of energy, material and water consumption as well as waste and emission in terms of volumes. These indicators become useful only, when the time series for both the nominator and the denominator are published together with the indicator. The eco-efficiency indicator can then show possible relative reduction of material input in relation to increased turnover or profit. However, as profit is influenced by other factors, like world market prices and exchange rates, the interpretation of these indicators is often difficult. Relating material input to turnover makes more sense, as this gives a direct relation to production. Examples are profit before taxes as opposed to turnover per unit water input for a brewery. Turnover would be more meaningful than profit, as is closer related to production input.

Turnover

Turnover is a very good indicator as it directly relates to production volume, which is used as the preferred reference for the material flow balance. As a physical measure from the material flow balance, the quantity of products produced and sold is the most useful denominator,

preferably measured in kg, but sometimes in volume or number. If physical data are not available, turnover in monetary terms is the second best choice.

Net sales

Net sales adjusts turnover by sales discounts, sales returns and allowances. Caution must be paid as production volumes are not directly linked to monetary sales figures, which are influenced by sales from stock, commodity prices, currency exchange rates and customer demand.

Value added

Value added is calculated as net sales minus costs of goods and services purchased. In theory, this indicator well reflects the contribution of a company to its "products value". It is calculated by reviewing the profit and loss accounts and deducting all items comprising "purchased goods and services" from revenues. However, as the term is not mandatory for disclosure in many countries, and its calculation requires a lot of accounting discipline, it may not be generally applied.

Gross margin

Is calculated as net sales minus costs of goods and services sold. Again, the term is not mandatory for disclosure, so its availability depends on company internal policies.

EBIT

Earnings before interest and tax (EBIT) is a well know financial indicator, used as a benchmark worldwide. It is also mandatory for disclosure by joint-stock companies. EBIT is calculated as net sales minus all expenses, except interest and income tax. The main difference to value added is that personnel and depreciation have also been deducted from turnover.

Net Profit after tax

This is not a good indicator, as the influence of financing factors significantly distorts comparison. Also differing tax laws and tax reduction provisions make interpretation difficult.

8. APPLICATION EXAMPLE - CALCULATING COST SAVINGS OF ENVIRONMENTAL PROJECTS AND INVESTMENTS

Industry managers face a growing dilemma when it comes to environmental investment decisions. On the one hand, regulatory requirements, voluntary standards, and market pressures impose continually higher, and more costly, demands for environmental performance. On the other hand, the information needed to fashion a cost-effective response to such demands is typically unavailable in a timely, rigorous, and consistent way. The result is that decisions on investment and management projects, materials choices, product pricing, and product mix often serve neither the best interests of the firm nor the environment.

Most companies have problems quantifying the cost savings of environmental management systems and other environmental activities. Companies generally calculate the cost savings of environmental management by comparing waste streams before investments and good housekeeping measures with later disposal and other costs, or by comparing old and new performance indicators and calculating the difference in monetary value. Most of these calculations are based on the question: What would I have to pay today if I hadn't invested or acted a couple of years ago? Future oriented calculations additionally face information gaps and uncertainty to answer the question: What will I have to pay in the future if I don't invest or act now?

Most of these calculations cover only a tiny part of corporate benefits of environmental management or investments. This is, because the calculations are typically done not by the accountant, but by the environmental manager, who is aware neither of the total corporate costs of emission treatment, pollution prevention and material efficiency, nor of the methods and principles behind capital budgeting. The environmental manager is struggling to speak "a foreign language", monetary instead of physical terms but without a complete assessment of annual corporate environmental costs as proposed in chapters 4 and 5, only a fraction of total costs will be visible.

Conclusions from several case studies emphasize the need for

- Improved consistency between physical and monetary data and related departments
- Material flow accounting as a basis for good cost accounting, and
- Adequate treatment of contingent costs for the assessment of investment decisions.

8.1. Capital Budgeting Basics

The basic idea of capital budgeting is to compare different investment alternatives.

Investment appraisal is used to determine the cost savings of an investment with regard to its goals. The economical variables for assessment in static financial analysis include :

- Initial investment costs
- Operating costs and earnings,
- Profit,
- Return on Investment, and
- Pay-back period.

All methods of investment appraisal assume that all inputs and outputs of an investment decision are quantifiable and can be monetarized.

In dynamic financial analysis, the expected future monetary inflows and outflows are discounted to the time of the investment and calculated into internal discount rate or annuity.

The opportunity costs of capital (the lower value of cash flows which don't occur today, but only in the future) are considered by discounting them with the interest rate of financial markets. The sum of all discounted future cash flows determines the net present value of a project or investment, which is compared to the value of the old equipment and to the interest rate of financial markets. A planned investment has to be more profitable than gaining interest on a bank deposit.

Payback methods for capital budgeting do not consider cash flows beyond the payback period. Many companies adopt internal rules, that only projects with a payback period of 2 or 3 years or less will be accepted, regardless of possible longer term benefits. Discounted cash flow methods in principle consider all relevant future cash flows until the project ends, but as many companies apply excessively high interest rates, which result in a negligible present value for medium and long term costs and savings, only the first 3 years or so count significantly for the investment decision.

The approach and shortcomings of methods such as the payback period, internal rate of return, or internal interest rate (IRR) are discussed in any textbook on corporate finance.

The methods for determining the value of a company for mergers and acquisition are also based on capitalized future earnings. Low environmental risks and the capacity to respond to future trends and stakeholder demands can increase the value of the company.

The high risks, difficult monetization and high uncertainty of many environment related future costs, as well as the potential cost savings of cleaner technologies arising from the reduced use of hazardous auxiliary and operating materials and related environmental protection measures have made estimation of the future even more difficult. Still, the methods are widely used. The task is not so much to change the basic concept of discounting future monetary flows, but to ensure the inclusion of all relevant earnings and expenses.

8.2. Budgeting for environmental protection

From the point of view of environmental protection investments, conventional investment appraisal methods can often not be used without adoption. Quantifying future earnings and output flows resulting from measures for environmental protection is a difficult venture. Particularly in the area of environmental management, one must often work with "soft" or less tangible data. In addition to pure investment and operation costs, factors such as image, contacts with environmental and other agencies, legal compliance, employee motivation etc. need consideration. As discussed in chapter 3, the determination of the "environmental" part of investments and operational expenditure is difficult.

In a compliance context, a factory's choice between an end-of-pipe or a prevention strategy will depend heavily on the comparative economics of these options. This is so even in instances where profitability is negative, that is, when the firm expects a net loss on its investment. Unlike most end-of-pipe technologies, pollution prevention projects tend to reduce operating costs by reducing waste generation, regulatory activities, and pollution related liabilities. In addition, investments in pollution prevention may increase revenue by improving product or corporate image. Including these indirect or less tangible benefits in the financial analysis of projects may enhance the estimated profitability of the prevention strategy, and may be decisive in selecting a pollution prevention versus an end-of-pipe option. It is at this decision point that the concepts and methods of **Total Cost Assessment (TCA)** -- the comprehensive, long-term financial analysis of pollution prevention projects -- can play a role in improving the financial picture of a pollution prevention investment, and enhance its competitiveness vis-a-vis end-of-pipe projects. TCA

techniques can also improve the projected financial performance of discretionary pollution prevention projects, thereby increasing their ability to compete for limited capital resources ¹⁷.

In addition to initial investment and annual operating expenditure,

- Future liability costs and
- Saving potentials

need consideration for investment appraisal.

Initial investment costs can comprise several items in addition to the purchased equipment. Depending on whether the equipment is classified as waste treatment or integrated technology, it's initial costs or annual depreciation, depending on the method used for investment appraisal will show up under section 1.1. or 2.3. of figure 42.

Annual operating costs can relate to all the other cost categories of the roll over scheme. Therefor, annual assessment of total expenditure is vital as a starting point in environmental management accounting. It assures the once complete picture, which later allows to consider only parts, related to specific cost centers or equipment.

Measures for pollution prevention help to reduce disposal and emission treatment costs and to increase the efficient use of purchased materials. Often, when calculating investments, the reduced costs for materials and emission treatment are not completely calculated, which results in distorted investment decisions.

Additionally, future liability costs and less tangible benefits should be estimated.

Future Liability Costs: Two general forms of future liability costs can be distinguished: liability for personal injury or property damage (e.g. liability stemming from a leaking landfill), and penalties and fines for violation of environmental regulations. To the degree that a clean up obligation is legally required, a provision has to be made in the balance sheet. But, as discussed, there are severe limits in tax and accounting standards for setting provisions. Therefor, when calculating future risks and liabilities, an estimate of avoided future liability is also required.

The less tangible factors considered by the Tellus institute are show in figure 42.

<p>Productivity</p> <ul style="list-style-type: none"> ◆ Product quality ◆ Production throughput ◆ Production flexibility ◆ Production reliability ◆ Worker absenteeism ◆ Worker morale 	<p>Potential Liability</p> <ul style="list-style-type: none"> ◆ business shutdown costs ◆ noncompliance fines ◆ site clean-up costs ◆ legal costs ◆ personal injury claims ◆ property damage claims ◆ natural resource damage claims 	<p>Insurance</p> <ul style="list-style-type: none"> ◆ worker's health insurance ◆ workers' compensation ◆ general property cor fire insurance ◆ general liability/hazard ◆ environmental liability ◆ unemployment
<p>Future Regulation</p> <ul style="list-style-type: none"> ◆ Stricter enforcement of current regulations ◆ Modification of current regulations ◆ New regulations 		<p>Company Image</p> <ul style="list-style-type: none"> ◆ access to customers and markets ◆ access to financing ◆ public relations

Figure 42: Less tangible factors

(Source: Tellus Institute, Bostsn, MA, 2000)

¹⁷ see White A., 1993 and Savage D.E. and White A.L., 1995,

¹⁸ see White A., 1993 and Savage D.E. and White A.L., 1995,

Saving potentials: Less tangible benefits from pollution prevention investments, such as increased revenue from enhanced product quality, company or product image, and reduced worker health maintenance costs or productivity are certainly the most difficult to predict and quantify.

The following saving potentials should be considered:

- Cost reduction for waste and emission treatment and disposal costs. This includes internal and external treatment, related equipment and operating materials, personnel handling waste, storage and landfill costs, fees for disposal, transport, insurance and liability, site and production permits, reports to authorities, etc..
- Savings of insurance, liability and remediation costs. Reduced waste and emissions and new processes requiring less harmful operating materials are often also a good argument for reduced risks of damage, spills, land contamination, cleanup-obligations or other possible remediation costs.
- Maintenance: Labor and material for maintenance can also be effected by product design and cleaner technologies.
- Savings in energy and water input: Generally, cleaner technologies not only require less material input but are also more energy and water efficient.
- Savings in raw and auxiliary materials and packaging. Alternatives which reduce the amount of waste, in general also need less material input.
- Savings because of better product quality. Alternative product design can improve the product quality and thereby reduce the costs of quality control, redoing work and production of scrap.
- Earnings from new by-products. If waste is replaced by new, marketable by-products, the cost of new product design can be offset by those earnings.
- Reduced risk of accidents and worker absenteeism by avoiding dangerous materials and processes which also results in increased employee motivation.
- Improved relations with local authorities speed up the time required for production permits and other official procedures.
- Future investment savings through anticipation of planned policy changes (i.e. stricter emission allowances, prohibited use of hazardous materials), thus preventing the requirement for short term or end-of-pipe solutions.

Additionally to saving, other positive effects can arise from environmental management. These so-called soft factors, structured by stakeholder relations, can be:

- Increased turnover, customer satisfaction, new markets, differentiation from competitors
- Image enhancement
- Better relations with authorities , reduced regulatory compliance costs,
- Better creditworthiness with banks, reduced insurance rates, good ratings by investment brokers and agencies
- Better public stockholder and community relations
- Increased job motivation and satisfaction, less absenteeism and worker illness

8.3. Calculation sheet for environmental investments and projects

The calculation sheet for investments and projects can be used to calculate 2 alternatives and comparing them, or to directly estimate resulting cost savings. An annual assessment of total environmental expenditures should have been performed beforehand, in order to provide a comparison basis. Depending on the project or investment, only some columns and rows may be filled, but the likelihood of forgetting significant cost factors is decreased. Allocation to the different environmental media will probably not be necessary, so the columns have been modified to time series.

Once the total environmental costs of 2 alternatives have been assessed for one year, they can be extended into time series for capital budgeting. Estimates of monetary inputs and outputs for the first 3 years should be more detailed. For years 4 to 10 rough annual estimates would be sufficient.

The determination of total annual environmental expenditure for the last business year is a prerequisite for calculating options. If the total annual environmental costs have not been assessed, the savings potential can't be calculated. After the determination of the total annual environmental costs, the calculation can be done for specific cost centers or production processes. Calculating different options is then relatively straightforward.

When comparing investment options, it is advisable to first assess the cost of the old equipment with the proposed scheme and then calculate the costs of the new equipment.

The so-called soft factors or less tangibles, which are rough estimates, can be added, if necessary.

Calculation sheet	Initial invest	Year 1	Year 2	Year 3	Year 4 ff.	Future liability	Soft factors
Environmental cost/expenditure categories							
1. Waste and Emission treatment							
1.1. Depreciation for related equipment							
1.2. Maintenance, operating materials, services							
1.3. Personnel							
1.4. Fees, Taxes, Charges							
1.5. Fines and Penalties							
1.6. Insurance for environmental liabilities							
1.7. Provisions for clean up costs, remediation							
2. Prevention and environm. Management							
2.1. External services for environm. Management							
2.2. Personnel for general environmental management activities							
2.3. Research and development							
2.4. Extra expenditure for integrated technologies							
2.5. Other environmental management costs							
3. Material Purchase Value of non-product output							
3.1. Raw materials							
3.2. Packaging							
3.3. Auxiliary materials							
3.4. Operating materials							
3.5. Energy							
3.6. Water							
4. Processing Costs of non-product output							
Σ Environmental Expenditure							
5. Environmental Revenues							
5.1. Subsidies, Awards							
5.2. Other earnings							
Σ Environmental Revenues							
6. Soft factors							
Increased turn over, customer satisfaction, new markets, differentiation from competitors, Improved customer relationships							
Improved corporate image							
Improved contacts with authorities and agencies, reduced legal compliance costs							
Reduced risks for accidents, liabilities and contaminated land							
Increased credit worthiness, better ratings by investment companies							
Better community relations							
Increased employee motivation and morale, less worker illness and absenteeism							
Σ Total Benefit							

Figure 42: Calculation sheet for environmental investments and projects

Several case studies, especially by the Tellus institute ¹⁹, confirm the following results:

1. Effective cost accounting requires effective material flow accounting. This point cannot be overstated. Environmental costs arise when materials are used, processed and released as non-product outputs. Understanding material flows as they move through a production system is a prerequisite to identifying and tracking environmental costs. Material flow balances are the most rigorous basis for developing such information, but short of this, improved materials accounting and screening process flow diagrams may well suffice in the first round. A single omission or error in defining relevant materials or energy flows can create major cost consequences that may lead to misguided management decision-making. Moreover, sound material flow accounting also serves as a useful screening device to avoid unnecessary expenditures of staff resources on estimating environmental costs that are relatively insignificant compared to other project costs.

2. Key environmental costs are contingent in nature; environmental accounting systems must be designed to handle such contingencies. Many "environmental costs" are contingent, or probabilistic, in nature. They are driven by future conditions or events with uncertain, but estimable, probabilities and cost outcomes. Future regulatory compliance costs and liability, personal or property damage are examples. Conventional financial accounting practices are not designed to handle contingent costs; in fact, contingencies are generally avoided in financial reporting and where they do appear, are subject to strict standards for estimation and disclosure. But such standards have little to do with environmental costs for purposes of internal decision-making. Effective environmental accounting requires an awareness of this critical difference and a willingness to experiment with different methods for dealing with contingent costs. Scenario analysis and actuarial-based cost estimation point to two approaches to handling the inevitable uncertainties associated with future environmental costs. Tools such as these are an integral part of any environmentally-conscious cost budgeting system.

3. Improvements can't be achieved by simply installing new software. There is no separate software for environmental accounting that solves all problems. Those seeking such a definitive, all-encompassing stand-alone solution are likely to be disappointed. Because environmental cost information serves so many different functions in the organization, the "system" is better thought of as a set of adjustments to current cost accounting systems, all with the purpose of identifying, tracking, and reporting environmental information to sharpen management decisions. More rigorous process flow information, linked with allocation of overhead costs to the respective cost centers and objects is vital. This amounts to nothing more than sound management and engineering practices being applied also to environmental projects.

4. Improved environmental management accounting still is not full accounting of all environmental cost. Internal costs are, by definition, limited to those with measurable financial consequences to the firm. They do not include environmental costs that accrue to identifiable third parties or to society as a whole, such as the cost of biodiversity loss owing to unsustainable forest practices or wetlands loss, global warming owing to carbon emissions, or forest, crop or building damages linked to acid rain deposition. Full cost accounting in its broadest sense would encompass such costs. It is the task of governments to ensure that these costs are internalized by applying appropriate fiscal instruments. While the direction of environmental regulations and international accords and standards is to extend the corporate cost net outward to internalize such external costs, few firms today are anticipating them in their calculations.

¹⁹ White A., Savage D., Becker M., 1993

9. OUTLOOK

Since the mid 1980s, several forces have encouraged the shift to prevention-oriented strategies, including liability under the federal Superfund Act in the US, public concerns with environmental degradation worldwide, increasingly stringent pollution control requirements in Europe, and widely publicized industrial accidents. As a result, firms have faced a rising tide of public demands for shifts to clean technologies and environmentally friendly products.

However, companies have been slow to move away from traditional end-of-pipe strategies toward more prevention-oriented practices. If, as many argue, pollution prevention pays, what accounts for this slow pace of change? If prevention investments are, in fact, in the interest of the firm, what accounts for the continuing reluctance to move aggressively toward a more preventative pollution management mode? And why, in light of the publicized benefits of pollution prevention, do firms, even large sophisticated ones, continue to be surprised when prevention-oriented projects produce advantages to the firm far beyond those expected of many conventional "must-do," compliance-driven capital investments?

The explanation for this apparent contradiction seems to be many-fold:

- (1) The organizational structure and behavior of companies inhibits pollution prevention projects from entering the decision-making process from the outside, thereby precluding these alternatives from consideration by the companies.;
- (2) Economic/financial barriers linked to methods of cost accounting and capital budgeting. Even if a pollution prevention project successfully entered the capital budgeting process, competition with other projects for limited capital resources is hampered by the poor knowledge of the true costs of non-product output.
- (3) Psychological and social effects. Often, increased responsibility for material flows and altered purchasing and stock management rules are not in the interest of department managers.

The barriers of traditional accounting have been the focus of this workbook. The basics of the different accounting procedures and opportunities for their improvement through determination of annual environmental expenditure, cost of non-product output, cost accounting for material flows and decreased allocation to overhead cost categories have been highlighted. Application focused on indicator development and investment appraisal.

Financial statement audits are increasingly considering general risks. Financial statement auditors seek to understand all significant aspects of business risk facing an organization and how those risks are managed, so as to develop the most effective approach to gain assurance about the reliability of management information and hence of reported information.

Business risk can be defined as any probability that the organization will not achieve its business objectives. Accordingly, as sustainability becomes more important to the objectives of a business and hence to its risk management and control processes, top management and financial statement auditors are increasingly interested as well.

For the purpose of verifying sustainability, the principles of financial statement audits provide the underlying methodology. There also is a trend from separate financial and environmental reporting towards combined sustainability reports. There is little merit in the long term in the development of environmental verification principles and financial statement audit principles on separate tracks, as "in principle" they should be the same. Likewise, there is little merit in two separate information systems in an organization, one for financial and cost accounting, the other for process technicians, if "in principle" they should be the same, following the material flows through the company.

Environmental and other sustainability issues have also become important topics for rating agencies. Investment companies are interested in how firms address future stakeholder

demands and how they manage future risks and anticipated legal obligations. A recent UK law, from July 2000, is explicitly requiring disclosure on how investment funds deal with sustainability issues in their stock portfolios. Still, this does not require consideration of ethical, social and environmental aspects for pension funds, but a strong push for green products on the stock market can be predicted.

Investors invest in companies which are listed on stock markets. The annual reports to shareholders contain consolidated results for the corporation. Reliable environmental reporting has been a major issue for companies recently and environmental reports are increasingly being externally verified. Thus, the disclosure of reliable environmental performance and costs data for the corporation, based on a solid information system that consistently collects and aggregates financial and physical data, is vital.

Annex

- 1. Checklists 105
 - 1.1. Checklist for Air + Climate..... 105
 - 1.2. Checklist for Waste Water..... 107
 - 1.3. Checklist for Waste 109
 - 1.4. Checklist for Soil and Ground Water..... 111
 - 1.5. Checklist for Noise and Vibration 113
 - 1.6. Checklist for Biodiversity and Landscape 115
 - 1.7. Checklist for Radiation 117
 - 1.8. Checklist for other environmental costs 119
- 2. Conversion factors 121
- 3. Material Flow Cost Accounting Charts 123
- 4. Literature 127

1. CHECKLISTS

1.1. Checklist for Air + Climate

Environmental cost/expenditure category	Air + Climate
1. Waste and Emission treatment	
1.1. Depreciation for related equipment	
<ul style="list-style-type: none"> • Filter plants, dust remover, biological filter • Recovery of fugative solvents • Respective deprecation for in house energy plants corresponding to efficiency losses (heating house, solar plant, wind ventilator) • Respective deprecation (corresponding to the losses) for plants for combined heat and power retrieval • Closed loop cooling systems • Building heating: respective part of non efficiency energy conversion • Air Conditioning • Environmentally relevant portion of the depreciation for production plants, i.e. post combustion in the paint facilities 	
1.2. Maintenance and operating materials and services	
<ul style="list-style-type: none"> • Operating materials and energy for the plant in accordance to 1.1., continual operation and for the conduction of inspections, maintenance servicing and repairs, with the respective shore of non efficient energy conversion • Maintenance services provided externally • External analysis and metrics costs • External testing costs, control and monitoring costs 	
1.3. Personnel	
<ul style="list-style-type: none"> • Energy administrator • Operation and maintenance of the in house energy related plant • Internal analysis and metrics costs • Internal testing costs, control and monitoring costs • Operational training for energy saving and conversion • Compliance with laws and specified corporate requirements • Compliance with documentation and notification obligations 	
1.4. Fees, Taxes, Charges	
<ul style="list-style-type: none"> • Energy related connection charges corresponding to conversion losses (i.e. district heat) • Energy tax (contained within purchasing price, imposed at delivery to grid most countries) • Taxes for air emissions 	
1.5. Fines and Penalties	
<ul style="list-style-type: none"> • Fines for non compliance with air emission 	
1.6. Insurance for environmental liabilities	
<ul style="list-style-type: none"> • Insurance against disturbance and accidents caused by released emissions 	
1.7. Provisions for clean up costs, remediation, etc.	
<ul style="list-style-type: none"> • Provisions for adaptation of end-of –pipe plants to state of art technologies 	
2. Prevention and environmental management	
2.1. External services for environmental management	
<ul style="list-style-type: none"> • Legal aid- and external consultation • Cost of training, literature and information material etc. 	
2.2. Personnel for general environmental management activities	

<ul style="list-style-type: none"> • Meetings of the management committee, departmental manager ,other employees, and the environmental team reporting related issues • Continual or occasional control measures, internal audits • Administrative processes, announcements and inquiries • Internal and external training or additional training including travel costs
2.3. Research and Development
<ul style="list-style-type: none"> • Research, development and trailing costs for emission prevention measures • Research and development measures for the prevention of energy conversion losses and emissions
2.4. Extra expenditure for cleaner technologies
<ul style="list-style-type: none"> • Additional costs in comparison to state of art technologies for additional energy efficiency improvements
2.5. Other environmental management costs
3. Material Purchase Value of non-product output
3.5. Energy
<ul style="list-style-type: none"> • Energy content of excess/waste heat (costs for components of energy carriers corresponding to conversion losses)
4. Processing Costs of non-product output
Σ Environmental Expenditure
5. Environmental Revenues
5.1. Subsidies, Awards
<ul style="list-style-type: none"> • Subsidies for technologies using renewable energy carriers • Construction costs and financial subsidies for in-house electricity production • Awards of optimal energy management
5.2. Other earnings
<ul style="list-style-type: none"> • Earnings from in-house produced electricity
Σ Environmental Revenues

1.2. Checklist for Waste Water

Environmental cost/expenditure category	WASTE WATER
1. Waste and Emission treatment	
1.1. Depreciation for related equipment	
<ul style="list-style-type: none"> • Depreciation for plants for means of waste water treatment i.e. rake, oil shunt, sand filter, cleaning in place (CIP)-facility, biological level • Caption tubs in the storage rooms to prevent groundwater contamination 	
1.2. Maintenance and operating materials and services	
<ul style="list-style-type: none"> • Operating materials and energy for the plant in accordance to 1.1.,for continual operation and for the conduction of inspections, maintenance servicing and repairs • Maintenance services provided externally • External analysis and metrics costs • External testing costs, control and monitoring costs 	
1.3. Personnel	
<ul style="list-style-type: none"> • Waste water administrator • Operation and maintenance of waste water facilities • Internal analysis and metrics costs • Internal testing costs, control and monitoring costs • Training for waste water treatment and prevention • Compliance with laws and specified corporate requirements • Compliance with documentation and notification obligations 	
1.4. Fees, Taxes, Charges	
<ul style="list-style-type: none"> • Channel connection fees • Charges for waste water input into public sewage plants • Charges for legal compliance to laws regulating water contamination • Tax for water extraction, waste water freight and amount 	
1.5. Fines and Penalties	
<ul style="list-style-type: none"> • For non-compliance of laws pertaining to water obligations 	
1.6. Insurance for environmental liabilities	
<ul style="list-style-type: none"> • Insurance for sanitation measures and compensations following cases of disturbance and accidents, also by damages caused during transport (LKW, Lorry faults) 	
1.7. Provisions for clean up costs, remediation, etc.	
<ul style="list-style-type: none"> • Provisions for cleaning measures and compensation following disturbances and accidents • Provisions for sanitation of groundwater • Provisions for adaptation of end-of-pipe plants to the state of art technologies 	
2. Prevention and environmental management	
2.1. External services for environmental management	
<ul style="list-style-type: none"> • Legal aid- and external consultancy in the area of water management • Cost of training, literature and information material etc. 	
2.2. Personnel for general environmental management activities	
<ul style="list-style-type: none"> • Meetings of the management committee, departmental manager, other employees, and the environmental team reporting related issues • Continual or occasional control measures, internal audits • Administrative processes, announcements and inquiries • Internal and external educational and training including travel costs • Implementation of corporate water saving projects • Communication with neighbors/fishermen and other external communication 	
2.3. Research and Development	
<ul style="list-style-type: none"> • Research, development and trailing costs for waste water prevention and water savings 	
2.4. Extra expenditure for cleaner technologies	

<ul style="list-style-type: none"> • Additional costs in comparison to the state of art technologies, in particular waste water prevention processes • Deprecation for water saving measures and water cycle closure
2.5. Other environmental management costs
3. Material Purchase Value of non-product output
3.1. Raw materials
<ul style="list-style-type: none"> • Material purchase value of raw materials ending up in waste water, i.e. hop and malt
3.2. Packaging
<ul style="list-style-type: none"> • Material purchase value of packaging materials ending up in waste water
3.3. Auxiliary materials
<ul style="list-style-type: none"> • Material purchase value of auxiliary materials ending up in waste water, i.e. sugar, yeast
3.4. Operating material
<ul style="list-style-type: none"> • Material purchase value of operating materials ending up in waste water, i.e. dyes, cleansing agents, chemicals
3.6. Water
<ul style="list-style-type: none"> • Material purchase value of fresh water going down as waste water
4. Processing costs of non-product output
<ul style="list-style-type: none"> • Manufacturing cost surcharge in accordance with treatment depth for personnel, depreciation, and operating materials of the non-product output
Σ Environmental Expenditure
5. Environmental Revenues
5.1. Subsidies, Awards
<ul style="list-style-type: none"> • Construction costs and financing subsidies for sewage plants • Subsidy for groundwater sanitation
5.2. Other earnings
<ul style="list-style-type: none"> • Earnings from the sewage plant made available to external companies
Σ Environmental Revenues

1.3. Checklist for Waste

Environmental cost/expenditure category	WASTE
1. Waste and Emission treatment	
1.1. Depreciation for related equipment	
<ul style="list-style-type: none"> • Plants for waste separation i.e. waste separation system, collection containers • Investments in waste separation sites and their construction i.e. caption tank, mesh collection boxes, receptacles, labeling, construction costs for waste collection islands • Plants for waste treatment i.e. sanitation presses, press and tilt container, chemical and physical treatment plants, disinfection plants, sterilisation plants • Drying plants for damp waste such as i.e. Label by the bottle washing machine • Waste related metrics, documentation and laboratory facilities • Plants for the extension of disposal intervals of operating materials i.e. grease, cooling devices • Process safety equipment for hazardous substances and waste • Transport systems i.e. proportionate depreciation for trucks, tractors, stacks for collection and disposal, including safety equipment such as double sided conversion tanks 	
1.2. Maintenance and operating materials and services	
<ul style="list-style-type: none"> • Operating materials and energy for plant in accordance to 1.1, continual operation to conduct inspections, maintenance servicing, and repairs • Maintenance services provided externally • External analysis and metrics costs • External testing costs, control and monitoring costs • Transport costs for vehicles, i.e. for delivery of waste to disposal sites or to recycled • Rent for waste collection containers and separation systems 	
1.3. Personnel	
<ul style="list-style-type: none"> • Waste administrator • Cleaning of waste collection locations • Internal handling of waste such as i.e. collection, compaction, drying, internal waste transport • Internal analysis and metrics costs • Internal testing, control and monitoring costs • Self delivery of waste to disposal sites or to recycling • Corporate training of waste separation and prevention • Compliance with waste regulations and corporate specific requirements i.e. creation of economic waste prevention plans • Filing and record keeping for (hazardous) waste disposal 	
1.4. Fees, Taxes, Charges	
<ul style="list-style-type: none"> • Disposal cost of municipal and hazardous waste including weighting charges container rental, container destruction etc. • Waste disposal fees and charges (public waste disposal) • Recycling costs for residues such as : paper, packaging materials, plastics, organic waste, metal etc. • Taxes for waste and clean up for contaminated sites (as exists) • License tax for product packaging • Charges for municipal permits reporting waste management • Charges for licenses and corporate plant production permits in connection with the processing of hazardous materials 	
1.5. Fines and Penalties	
<ul style="list-style-type: none"> • For neglecting to comply with waste related regulations, regarding separation, monitoring, transport and disposal 	

1.6. Insurance for environmental liabilities
<ul style="list-style-type: none"> • Insurance against the risk of accidents during transportation of hazardous goods and waste
1.7. Provisions for clean up costs, remediation, etc.
<ul style="list-style-type: none"> • Provisions for neglected overburden removal in mining • Provisions for waste removal and recycling obligations • Provisions for adaptation of end-of-pipe plants to the state of art technologies
2. Prevention and environmental management
2.1. External services for environmental management
<ul style="list-style-type: none"> • Legal aid and external consultancy in the area of waste management • Costs for training, literature and information materials etc.
2.2. Personnel for general environmental management activities
<ul style="list-style-type: none"> • Meetings of the management committee, departmental manager, other employees, and the environmental team reporting related environmental issues • Continual or occasional control measures, internal audits • Waste related administration processes, announcements and inquiries • Internal and external education and training, including travel costs • Product design costs to change design to reduce waste • Planning costs for process changes that reduce waste • Emergency response planning and training with regard to hazardous substances
2.3. Research and Development
<ul style="list-style-type: none"> • Research, development and trailing costs for waste prevention measures
2.4. Extra expenditure for cleaner technologies
<ul style="list-style-type: none"> • Additional costs in comparison to the state of art technologies in regard to special waste prevention processes
2.5. Other environmental management costs
3. Material Purchase Value of non-product output
3.1. Raw materials
<ul style="list-style-type: none"> • Material purchase value of raw materials ending up in waste
3.2. Packaging
<ul style="list-style-type: none"> • Material purchase value of packaging materials ending up in waste
3.3. Auxiliary materials
<ul style="list-style-type: none"> • Material purchase value of auxiliary materials ending up in waste
3.4. Operating materials
<ul style="list-style-type: none"> • Material purchase value of operating materials ending up in waste, as long as it is not already contained in 1.2
4. Processing Costs of non-product output
<ul style="list-style-type: none"> • Manufacturing cost surcharge in accordance with treatment depth for personnel, depreciation, and operating materials of the non-product output
Σ Environmental Expenditure
5. Environmental Revenues
5.1. Subsidies, Awards
<ul style="list-style-type: none"> • Construction costs and financing subsidies for waste related plants • Awards for optimal waste management
5.2. Other earnings
<ul style="list-style-type: none"> • Earnings from the sale of materials for reuse and recycling (paper, packaging, plastics, glass, biological waste etc.)
Σ Environmental Revenues

1.4. Checklist for Soil and Ground Water

Environmental cost/expenditure category	SOIL AND GROUND WATER
1. Waste and Emission treatment	
1.1. Depreciation for related equipment	
<ul style="list-style-type: none"> • Processes for the treatment of soil contamination • Recultivation of land • Reforestation measures • Landscape design for industrial plants, nuclear power plants etc. • Protection measures for in-house disposal sites 	
1.2. Maintenance and operating materials and services	
<ul style="list-style-type: none"> • Operating materials and energy for the plants in accordance to 1.1., continual operation and for the conduction of inspections, maintenance servicing and repairs • Maintenance services provided externally • External analysis and metrics costs • External testing costs, control and monitoring costs 	
1.3. Personnel	
<ul style="list-style-type: none"> • Operation and maintenance of the plants in accordance with 1.1. • Internal analysis and metrics costs • Internal testing costs, control and monitoring costs • Training for treatment and prevention • Compliance with laws and specified corporate requirements • Compliance with documentation and notification obligations 	
1.4. Fees, Taxes, Charges	
<ul style="list-style-type: none"> • Charges for clean up of contaminated land 	
1.5. Fines and Penalties	
<ul style="list-style-type: none"> • For neglecting to comply with the obligations of individual disposal sites 	
1.6. Insurance for environmental liabilities	
<ul style="list-style-type: none"> • Insurance against disturbance and accidents caused in on-site disposal sites 	
1.7. Provisions for clean up costs, remediation, etc.	
<ul style="list-style-type: none"> • Provisions for reforestation and recultivation • Provisions for the clean up of disposal sites and contaminated land • Provision for the adaptation of end-of-pipe plants in line with state of art technologies 	
2. Prevention and environmental management	
2.1. External services for environmental management	
<ul style="list-style-type: none"> • Legal aid- and external consultancy • Cost of training, literature and information materials etc. 	
2.2. Personnel for general environmental management activities	
<ul style="list-style-type: none"> • Meetings of the management committee, departmental manager ,other employees, and the environmental team reporting related environmental issues • Continual or occasional control measures, internal audits • Administrative processes, announcements and inquiries • Internal and external education and training including travel costs 	
2.3. Research and Development	
<ul style="list-style-type: none"> • Research, development and trailing costs for prevention measures 	
2.4. Extra expenditure for cleaner technologies	
<ul style="list-style-type: none"> • Additional costs in comparison to state of art technologies specially dealing with the prevention of contaminated land 	
2.5. Other environmental management costs	
Σ Environmental Expenditure	
5. Environmental Revenues	

5.1. Subsidies, Awards
• Subsidies for disposal site sanitation
5.2. Other earnings
• Earnings from the utilisation of in-house disposal sites
Σ Environmental Revenues

1.5. Checklist for Noise and Vibration

Environmental cost/expenditure category	NOISE AND VIBRATION
1. Waste and Emission treatment	
1.1. Depreciation for related equipment	<ul style="list-style-type: none"> Noise absorption devices, Sound proof walls, Isolation Internal operating noise pollution measures (if not already attributed to Health and Safety) Environmentally relevant portion of the depreciation for production plants, i.e. sound absorption
1.2. Maintenance and operating materials and services	<ul style="list-style-type: none"> Operating materials and energy for the plants in accordance to 1.1., continual operation and for the conduction of inspections, maintenance servicing and repairs Maintenance services provided externally External analysis and metrics costs External testing costs, control and monitoring costs
1.3. Personnel	<ul style="list-style-type: none"> Emissions and Noise administrator Operation and maintenance of the plant in accordance with 1.1. Internal analysis and metrics costs Internal testing costs, control and monitoring costs Operational training for treatment and prevention Compliance with laws and specified corporate requirements Compliance with documentation and notification obligations
1.4. Fees, Taxes, Charges	<ul style="list-style-type: none"> Charges for administrative processes
1.5. Fines and Penalties	<ul style="list-style-type: none"> Fines for non compliance with noise related laws
1.6. Insurance for environmental liabilities	<ul style="list-style-type: none"> Insurance against disturbance and claims by neighbors
1.7. Provisions	<ul style="list-style-type: none"> Provisions for damage compensation following cases of disturbances Provisions for the adaptation of end-of-pipe plants in line with state of art technologies
2. Prevention and environmental management	
2.1. External services for environmental management	<ul style="list-style-type: none"> Legal aid- and external consultation performance in the area of air emission management Cost of training, literature and information materials etc.
2.2. Personnel for general environmental management activities	<ul style="list-style-type: none"> Meetings of the management committee, departmental manager, other employees, and the environmental team reporting related environmental issues Continual or occasional control measures, internal audits Administrative processes, announcements and inquiries Internal and external education and training including travel costs Communication with neighbors and other interested parties
2.3. Research and Development	<ul style="list-style-type: none"> Research, development and trailing costs for noise prevention measures
2.4. Extra expenditure for cleaner technologies	<ul style="list-style-type: none"> Additional costs in comparison to state of art technology, especially emission and noise prevention processes
2.5. Other environmental management costs	
3. Material Purchase Value of non-product output	
3.1. Raw materials	
3.2. Packaging	

3.3. Auxiliary materials
3.4. Operating materials
4. Processing Costs of non-product output
Σ Environmental Expenditure
5. Environmental Revenues
5.1. Subsidies, Awards
5.2. Other earnings
Σ Environmental Revenues

1.6. Checklist for Biodiversity and Landscape

Environmental cost/expenditure category	BIODIVERSITY AND LANDSCAPE
1. Waste and Emission treatment	
1.1. Depreciation for related equipment	<ul style="list-style-type: none"> Environmentally relevant portion of the depreciation for production plants, i.e. special measures taken for landscape design
1.2. Maintenance and operating materials and services	<ul style="list-style-type: none"> Operating materials and energy for the plants in accordance to 1.1., continual operation and for the conduction of inspections, maintenance servicing and repairs Maintenance services provided externally External analysis and metrics costs External testing costs, control and monitoring costs
1.3. Personnel	<ul style="list-style-type: none"> Operation and maintenance of the sites in accordance with 1.1. Internal analysis and metrics costs Operational training for treatment and prevention Compliance with laws and specified corporate requirements
1.4. Fees, Taxes, Charges	<ul style="list-style-type: none"> Charges for administrative processes
1.5. Fines and Penalties	
1.6. Insurance for environmental liabilities	
1.7. Provisions for clean up costs, remediation, etc.	<ul style="list-style-type: none"> Provisions for landscaping after construction activities
2. Prevention and environmental management	
2.1. External services for environmental management	<ul style="list-style-type: none"> Legal aid- and external consultation Cost of literature and information materials etc.
2.2. Personnel for general environmental management activities	<ul style="list-style-type: none"> Meetings of the management committee, departmental manager, other employees, and the environmental team reporting related environmental issues Continual or occasional control measures, internal audits Administrative processes, announcements and inquiries Internal and external education and training including travel costs Communication with neighbors and other interested parties
2.3. Research and Development	<ul style="list-style-type: none"> Research and development for biodiversity and landscaping
2.4. Extra expenditure for cleaner technologies	<ul style="list-style-type: none"> Additional costs in comparison to state of art technology
2.5. Other environmental management costs	<ul style="list-style-type: none"> Ecosponsoring activities, projects for protecting wildland, rainwood forests etc.
3. Material Purchase Value of non-product output	
3.1. Raw materials	
3.2. Packaging	
3.3. Auxiliary materials	
3.4. Operating materials	
4. Processing Costs of non-product output	
Σ Environmental Expenditure	
5. Environmental Revenues	
5.1. Subsidies, Awards	

5.2. Other earnings

Σ Environmental Revenues

1.7. Checklist for Radiation

Environmental cost/expenditure category	RADIATION
1. Waste and Emission treatment	
1.1. Depreciation for related equipment	
<ul style="list-style-type: none"> • Radiation proof walls, Isolation • Internal operating radiation measures (if not already attributed to Health and Safety) • Environmentally relevant portion of the depreciation for production plants, i.e. radiation absorption 	
1.2. Maintenance and operating materials and services	
<ul style="list-style-type: none"> • Operating materials and energy for the plants in accordance to 1.1., continual operation and for the conduction of inspections, maintenance servicing and repairs • Maintenance services provided externally • External analysis and metrics costs • External testing costs, control and monitoring costs 	
1.3. Personnel	
<ul style="list-style-type: none"> • Radiation administrator • Operation and maintenance of the plant in accordance with 1.1. • Internal analysis and metrics costs • Internal testing costs, control and monitoring costs • Operational training for treatment and prevention • Compliance with laws and specified corporate requirements • Compliance with documentation and notification obligations 	
1.4. Fees, Taxes, Charges	
<ul style="list-style-type: none"> • Charges for administrative processes 	
1.5. Fines and Penalties	
<ul style="list-style-type: none"> • Fines for non compliance with related laws 	
1.6. Insurance for environmental liabilities	
<ul style="list-style-type: none"> • Insurance against disturbance and accidents caused by radiation 	
1.7. Provisions for clean up costs, remediation, etc.	
<ul style="list-style-type: none"> • Provisions for damage compensation to injured and their dependants following cases of disturbances and accidents • Provisions for treatment of radioactive contamination • Provisions for the adaptation of end-of-pipe plants in line with state of art technologies 	
2. Prevention and environmental management	
2.1. External services for environmental management	
<ul style="list-style-type: none"> • Legal aid- and external consultation performance in the area of radiation management • Cost of training, literature and information materials etc. 	
2.2. Personnel for general environmental management activities	
<ul style="list-style-type: none"> • Meetings of the management committee, departmental manager, other employees, and the environmental team reporting related environmental issues • Continual or occasional control measures, internal audits • Administrative processes, announcements and inquiries • Internal and external education and training including travel costs • Communication with neighbors and other interested parties 	
2.3. Research and Development	
<ul style="list-style-type: none"> • Research, development and trailing costs for radiation prevention measures 	
2.4. Extra expenditure for cleaner technologies	
<ul style="list-style-type: none"> • Additional costs in comparison to state of art technology 	
2.5. Other environmental management costs	
3. Material Purchase Value of non-product output	

3.1. Raw materials
3.2. Packaging
3.3. Auxiliary materials
3.4. Operating materials
4. Processing Costs of non-product output
Σ Environmental Expenditure
5. Environmental Revenues
5.1. Subsidies, Awards
5.2. Other earnings
Σ Environmental Revenues

1.8. Checklist for other environmental costs

This checklist applies to remaining costs only, which have not been distributed to environmental media. Whenever possible, the relevant costs should be attributed to the different environmental media, based on sound estimates.

Environmental cost/expenditure category	Other
1. Waste and Emission treatment	
1.1. Depreciation for related equipment	
1.2. Maintenance and operating materials and services	
1.3. Personnel	
<ul style="list-style-type: none"> • Compliance with laws and specified corporate requirements • Compliance with documentation and notification obligations 	
1.4. Fees, Taxes, Charges	
<ul style="list-style-type: none"> • Registration charge for entry into EMAS site register • Charges for administrative processes • Registration charge i.e. for eco labels 	
1.5. Fines and Penalties	
<ul style="list-style-type: none"> • Environmental penalties, compensations and settlements, if not distributed to the respective enviro media 	
1.6. Insurance for environmental liabilities	
1.7. Provisions for clean up costs, remediation, etc.	
2. Prevention and environmental management	
2.1. External services for environmental management	
<ul style="list-style-type: none"> • Legal aid- and external consultancy • Cost of training, literature and information materials etc • Environmental verifiers, certification and audit costs • External communication costs i.e. advertisements, environmental reporting 	
2.2. Personnel for general environmental management activities	
<ul style="list-style-type: none"> • Meetings of the management committee, departmental manager ,other employees, and the environmental team reporting environmental issues • Continual or occasional control measures, internal audits • Administrative processes, announcements and inquiries • Internal and external education and training including travel costs • General cost of environmental manager, general environmental administration • Implementation of an environmental management systems • Environmental communication, revision of inquiries, writing an environmental report • Communication with neighbors • Notification, reporting, monitoring/testing, studies/modeling, record keeping, inspections, 	
2.3. Research and Development	
<ul style="list-style-type: none"> • Research, development and trailing costs for general waste and emission prevention measures 	
2.4. Extra expenditure for cleaner technologies	
2.5. Other environmental management costs	
<ul style="list-style-type: none"> • Additional costs for purchasing environmentally sound products, if significant • Costs for support of local community environmental activities, such as providing funds, seminars and information • Costs for environmental advertisement and communication • Costs related with environmental trails 	
Σ Environmental Expenditure	

5. Environmental Revenues
5.1. Subsidies, Awards
<ul style="list-style-type: none">• Subsidies for general environmental management activity (i.e. installation of environmental management systems)• Awards for environmental management activities
5.2. Other earnings
Σ Environmental Revenues

2. CONVERSION FACTORS

Conversion for energy input in kg, liter or m3 into kWh

Natural gas	10,00 kWh/m ³	12,66 kWh/kg
Fuel oil light	9,93 kWh/l	11,68 kWh/kg
Fuel oil heavy	10,27 kWh/l	11,17 kWh/kg
Hard coal	-	8,14 kWh/kg
Brown coal	-	5,35 kWh/kg
District heating	Inquire at local public utility company	

Source: Guide to corporate environmental indicators, Federal Environmental Ministry, Bonn, Germany, 1997

Conversion for CO₂ emissions per kWh energy input

	CO ₂ in g/kWh
Natural gas	200
Fuel oil light	260
Fuel oil heavy	280
External supply of electricity	492 for Germany

Source: Study Commission of the German Bundestag (1994), European Electricity Supply Network (UCPTE 93)

Conversion factors for global warming emissions (Kyoto protocol)

Substance	Global warming potential GWP (1) time horizon 100 years, (kg CO ₂ equivalent per kg substance)
Carbon dioxide CO ₂	1
Methane CH ₄	21
Nitrous Oxide N ₂ O	270
Sulphur hexafluoride SF ₆	23.900
Perfluorocarbons PFCs	7.000 – 9.200
Hydrofluorocarbons HFCs	140 – 9.800

Source: Unctad

For a complete list of GWPs see IPCC 1996.

Conversion factors for ozone depleting emissions (Montreal protocol)

Substance	Ozon depleting potential ODP (kg CFC-11 equivalent per kg substance)
CFCI ₃ (CFC-11)	1,0
CF ₂ CI ₂ (CFC 12)	1,0
C ₂ F ₃ CI ₃ (CFC-113)	0,8
C ₂ F ₄ CI ₂ (CFC-114)	1,0
C ₂ F ₅ CI (CFC-115)	0,6
CF ₂ BrCI (halon-1211)	3,0
CF ₃ Br (halon-1301)	10,0
C ₂ F ₄ Br ₂ (halon-2402)	6,0
CF ₃ CI (CFC-13)	1,0
C ₂ FCI ₅ (CFC-111)	1,0
C ₂ F ₂ CI ₄ (CFC-112)	1,0
C ₃ FCI ₇ (cfc-211)	1,0
C ₃ F ₂ CI ₆ (CFC-212)	1,0
C ₃ F ₃ CI ₅ (CFC-213)	1,0
C ₃ F ₄ CI ₄ (CFC-214)	1,0

C3F5Cl3 (CFC-215)	1,0
C3F6Cl2 (CFC-216)	1,0
C3F7Cl (CFC-217)	1,0
CCl4 carbon tetrachlorid	1,1
C2H3Cl3 1,1,1-trichloroethane	0,1
CHCl2 (HCFC-21)1	0,04
CHF2Cl2 (HCFC-22)1	0,055
CH2Cl (HCFC-31)1	0,02
C2HFCl4 (HCFC-121)2	0,01 – 0,04
C2HF2Cl3 (HCFC-122)3	0,02 – 0,08
C2HF3Cl2 (HCFC-123)3	0,02 – 0,06
CHCl2CF3 (HCFC-123)	0 – 0,02
C2HF4Cl (HCFC-124)2	0,02 – 0,04
CHFClCF3 (HCFC-124)	0 – 0,022
C2H2FCl3 (HCFC-131)3	0,007 – 0,05
C2H2F2Cl2	0,02
C2HFCl4 (HCFC-121)2	0,01 – 0,04
C2HF2Cl3 (HCFC-122)3	0,02 – 0,08
C2HF3Cl2 (HCGroup IIICHFBr2)1	1,0
CHF2Br (HBFC-22B1)1	0,74
CH2FBr1	0,73
C2HFBr4 2	0,3 – 0,8
C2HF2Br3 3	0,5 – 1,8
C2HF3Br2 3	0,4 – 1,6
C2HF4Br2	0,7 – 1,2
C2H2FBr3 3	0,1 – 1,1
C2H2F2Br2 4	0,2 – 1,5
C2H2F3Br3	0,7 – 1,6
C2H3FBr2 3	0,1 – 1,7
C2H3F2Br3	0,2 – 1,1
C2H4FBr2	0,07 – 0,1
C3HFBr6 5	0,3 – 1,5
C3HF2Br5 9	0,2 – 1,9
C3HF3Br4 12	0,3 – 1,8
C3HF4Br3 12	0,5 – 2,2
C3HF5Br2 9	0,9 – 2,0
C3HF6Br5	0,7 – 3,3
C3H2Br5 9	0,1 – 1,9
C3H2F2Br4 16	0,2 – 2,1
C3H2F3Br3 18	0,2 – 5,6
C3H2F4Br2 16	0,3 – 7,5
C3H2F5Br 8	0,9 – 1,4
C3H3FBr4 12	0,08 – 1,9
C3H3F2Br3 18	0,1 – 3,1
C3H3F4Br 12	0,3 – 4,4
C3H5FBr2 9	0,04 – 0,4
C3H5F2Br 9	0,07 – 0,8
C3H6FBr 5	0,02 – 0,7

Where a range of OPDs is indicated, the highest value in that range shall be used, as these values are based on estimates, while single values are based on laboratory measurements.

3. MATERIAL FLOW COST ACCOUNTING CHARTS

Material Flow Model (e.g. Pharmaceutical Industry)

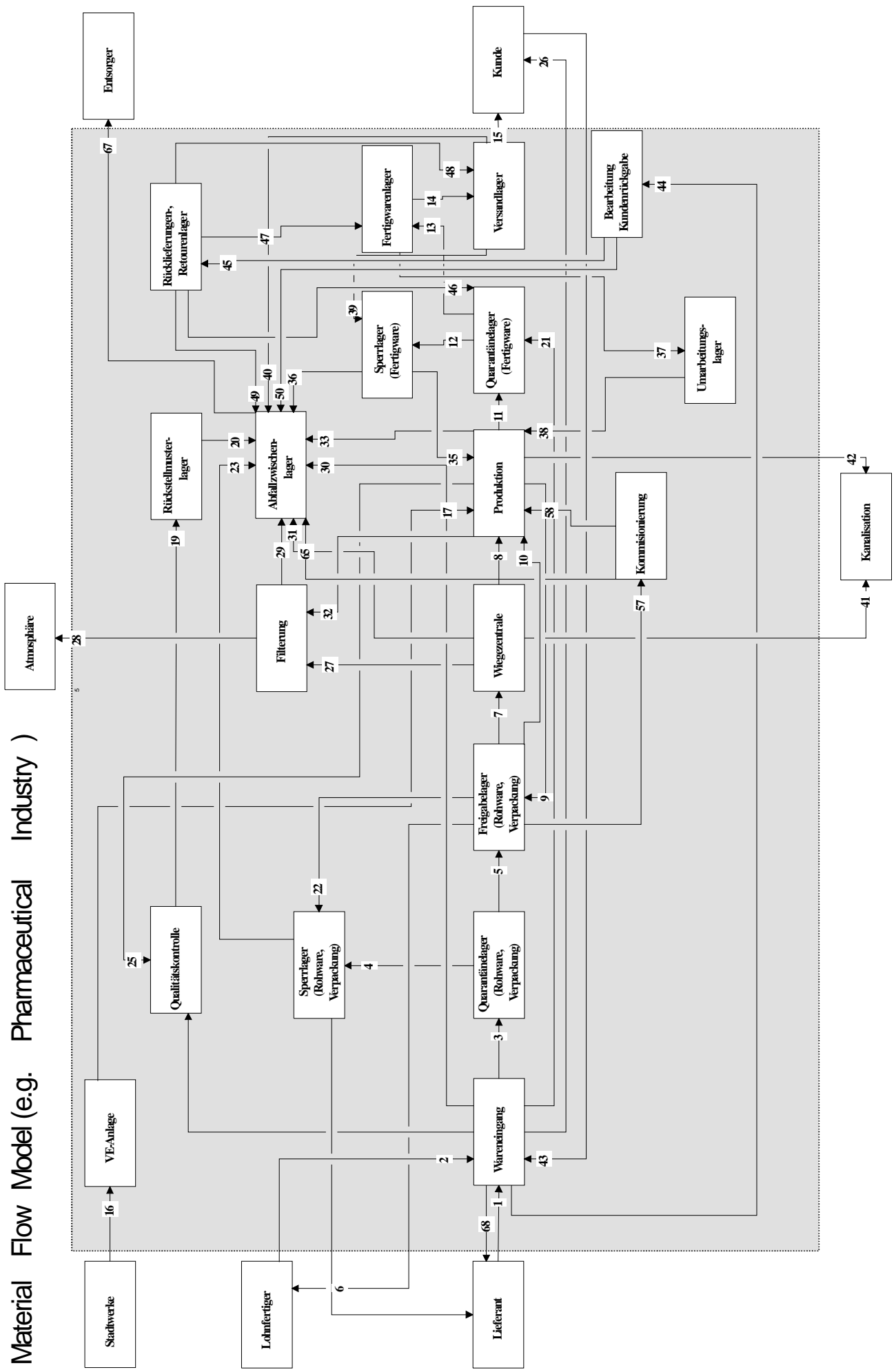

Exemplary Material flow model with material flow values and delivery and disposal costs (in millions of US \$)

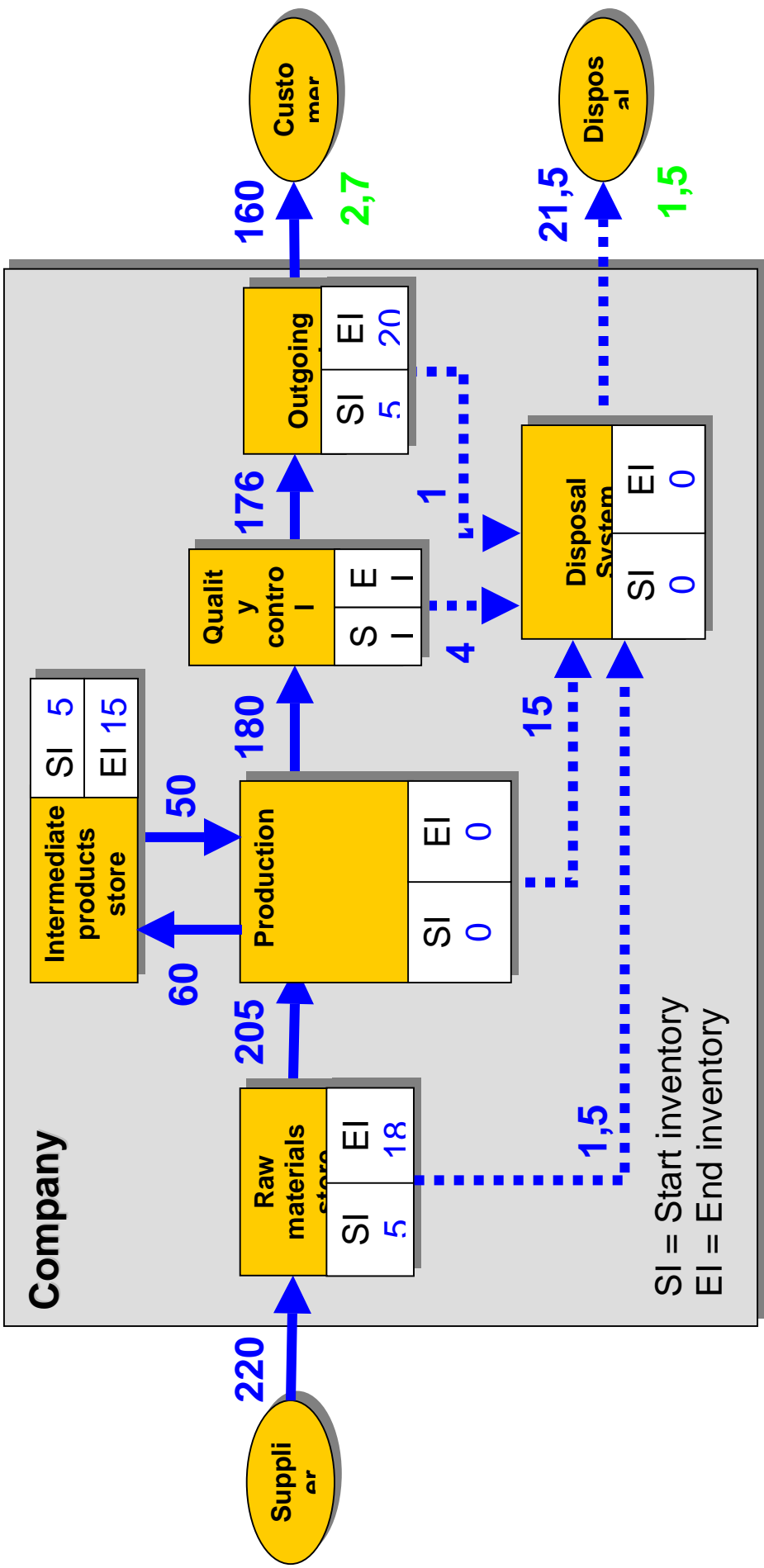

4. LITERATURE

- **Australian Society of Certified Practising Accountants**
Environmental Management Series, Melbourne, 1999
- **Bartolomeo M., Bennet P., Bouma J., Heydkamp P., James P., Wolters T.**
Eco management accounting as a tool of environmental management, Final report to the Ecomag project, sponsored by EU DG XII
- **Bennet M., James P.**
Applying Eco Management Accounting, EIM, Ecomag project, Wolverhampton 1999
- **Bouma J.J., Wolters J.**
Management Accounting and environmental Management: A survey among 84 European companies, Erasmus Center for environmental Studies, Rotterdam, 1998
- **Braun S., Clausen J., Lehmann S.,**
Nachhaltigkeit.Jetzt!, Hrsg.: Future e.V., München, 2000
- **Brealey, R., / Myers,S., (1991):**
Principles of Corporate Finance : Application of Option Pricing Theory (New York, NY : Mcgraw –Hill, 1991)
- **Bundesumweltministerium/Umweltbundesamt (Hrsg.),**
Handbuch Umweltkostenrechnung, Vahlen-Verlag, München 1996.
- **Bundesministerium für Wissenschaft und Forschung und Umwelt, Jugend und Familie (Hrsg.):**
PREPARE – Toolkit, Textbücher, Lösungen und Arbeitsblätter; Methodik zur betrieblichen Abfall- und Emissionsvermeidung; Graz, Wien Juli 1995
- **Comission of the European Union,**
White Paper on environmental Liability, Brussels, February 2000
- **Comission of the European Union,**
Draft Commission Recommendation on the recognition, measurement and disclosure of environmental issues in the annual accounts and annual reports of companies, Brussels, May 2000
- **Coopers & Lybrand (1997):**
Manufacturing Costing Benchmarking Study. Summary Feedback Document for Study Participants, Intern Draft: December 17, 1997 (Coopers Proprietary Information)
- **Dimitroff-Regatschnig H., Ferner H., Fresner J., Haberfehlner T., Jasch C., Schnitzer H.,**
PREPARE Österreich Toolkit – Textbücher, Arbeitsblätter und Lösungen, Hrsg.: Austrian Cleaner Production Center, Graz, 1998
- **Dimitroff-Regatschnig H., Jasch Ch., Schnitzer H.,**
Entwicklung eines methodischen Ansatzes zur Ableitung von Umweltkosten aus dem betrieblichen Rechnungswesen, Studie im Auftrag des Bundesministeriums für Umwelt, Jugend und Familie, Schriftenreihe 24/97 des IÖW, Wien, 1997
- **Dixit, A / Pindyck, R. (1993):**
Investment under Uncertainty (Princeton, NJ : Princeton University Press, 1993)
- **Dold, G. / Enzler, S. (1999):**
Effizientes Umweltmanagement durch ECO-Integral, in: Freimann, J. (Hg. 1999): Werkzeuge erfolgreichen Managements. Ein Compendium für die Unternehmenspraxis, Wiesbaden 1999, S. 71-93
- **Du Pont, (1993):**
Corporate Environmentalism : Progress Report (Wilmington, DE : Du Pont, 1993)
- **Environmental Agency Japan,**
Study group for developing a system for environmental accounting, Developing an Environmenatl Accounting System, 2000 Report, Japan 2000
- **Federal Environmental Ministry, Federal Environmental Agency, Bonn, Berlin,**
A guide to corporate environmental indicators, 1997
- **FEE, Federation des Experts Compables,**
Towards a generally accepted framework for environmental reporting, Brussel, July 2000
- **Fichter, K. / Loew, T. / Antes, R. (1999):**
Wissenschaftlicher Endbericht zum hessischen Modellprojekt Umweltkostenmanagement, unveröffentlichte Begleitstudie, August 1999
- **Fichter, K. / Loew, T. / Seidel, E. (1997):**
Betriebliche Umweltkostenrechnung. Methoden und praxisgerechte Weiterentwicklung, Berlin, Heidelberg 1997, ISBN 3-540-62597-6
- **Fischer, H. / Wucherer, Chr. / Wagner, B. / Burschel, C. (1997):**
Umweltkostenmanagement. Kosten senken durch praxiserprobtes Umweltcontrolling, München, Wien 1997, ISBN 3-446-18608-5
- **Fischer H., Wucherer C., Wagner B., Burschel C.,**
Umweltkostenmanagement, Carl Hanser Verlag, München Wien, 1997
- **GRI, Global Reporting Initiative,**
Sustainability Reporting Guidelines on Economic, Environmental and Social Performance, June 2000,
www.globalreporting.org
- **Hammer, B., / Stinson, C. (1993):**
Managerial Accounting and Compliance Costs (University of Washington discussion paper; Washington, DC : University of Washington, 1993)
- **Hessisches Ministerium für Wirtschaft, Verkehr und Landesentwicklung (Hsg.):** Flusskostenmanagement.
Kostensenkung und Öko-Effizienz durch eine Materialflussorientierung in der Kostenrechnung (Leitfaden), Wiesbaden 1999
- **Hopfenbeck W., Jasch C.:**
Öko-Controlling. Umdenken zahlt sich aus! Audits, Umweltberichte und Ökobilanzen als betriebliche Führungsinstrumente, Verlag Moderne Industrie, Landsberg/Lech, 1993, ISBN 3-478-34560-X.
- **Hopfenbeck W.:**

- Allgemeine Betriebswirtschafts- und Managementlehre. Das Unternehmen im Spannungsfeld zwischen ökonomischen, sozialen und ökologischen Interessen. 10. vollständig überarbeitete Auflage; Verlag Moderne Industrie, Landberg/Lech 1996
- **ISO 14031**,
Environmental Management – Environmental Performance Evaluation – Guidelines, International Standardisation Organisation, Geneva, 2000
 - **Jasch C.:**
Umweltbezug des Rechnungswesens. Ökologische Betriebsgesamtrechnung, Schriftenreihe 12/1992 des IÖW Wien, Juli 1992
 - **Jasch Ch.**, Rauberger R., Wagner B.
Leitfaden betriebliche Umweltkennzahlen. Hrsg: Umweltbundesamt, Berlin, 1997
 - **Jasch Ch.**, Rauberger R.;
1997 A Guide to Corporate Environmental Indicators. On behalf of the German Federal Ministry for the Environment and the German Federal Environmental Agency in Bonn, December. Auch in spanischer und baskischer Sprache herausgegeben
 - **Jasch Ch., Rauberger R.; 1998**
Leitfaden Kennzahlen zur Messung der betrieblichen Umweltleistung; Hrsg. Bundesministerium für Umwelt, Jugend und Familie, Wien 1998, Schriftenreihe 25/1998 des IÖW Wien
 - **Jasch Ch.**,
1998, Environmental Performance Indicators and standard framework of accounts, How to define system boundaries and reference units, in The Green Bottom Line – Environmental Accounting for Management; Bennet M., James P., Hrsg. Greenleaf Publishing, Sheffield U.K.
 - **Jasch Ch.**,
1999, Manual for environmental cost accounting, in Developing Eco-Management Accounting: An International Perspective, EMAN, EIM, Zoetermeer, July 1999
 - **Jasch Ch., Gyallay-Pap R.**,
Environmental Statements and Environmental Performance indicators in Austria and Germany; IOW Vienna, Informationsdienst 4/1998
 - **Johnson, H. / Kaplan, R. (1987)**,
Relevance Lost : The Rise and Fall of management Accounting (Boston, MA : Harvard Business School Press, 1987)
 - **Klein B.**,
Umweltschutzverpflichtungen im Jahresabschluss, Gabler Edition Wirtschaft, Wiesbaden, 1998
 - **Koechlin, D. / Müller, K. (1992):**
Environmental Management and Investment Decisions, in : D. Koechlin and K. Müller (eds.), Green Business Opportunities: The Profit Potential (London, UK: Pitman, 1992)
 - **Kottmann H., Loew T., Clausen J.**,
Umweltmanagement mit Kennzahlen, Verlag Vahlen, München, 1999
 - **Krcmar, H. / Dold, G. / Fischer, H. / Strobel, M. / Seifert, E. (2000):**
Informationssysteme für das Umweltmanagement. Das Referenzmodell ECO-Integral, München, Wien 2000, ISBN 3-486-25420-0
 - **Landesanstalt für Umweltschutz Baden-Württemberg (Hrsg.)**,
Arbeitsmaterialien zur Einführung von betrieblichen Umweltkennzahlen, Karlsruhe, 1999
 - **Landesanstalt für Umweltschutz Baden-Württemberg (Hrsg.)**,
Betriebliches Material- und Energieflußmanagement, ÖkoEffizienz durch nachhaltige Reorganisation, Karlsruhe, 1999
 - **Landesanstalt für Umweltschutz Baden-Württemberg (Hrsg.)**,
Leitfaden Umweltorientierte Unternehmensführung in kleinen und mittleren Unternehmen und in Handwerksbetrieben, Karlsruhe 1995
 - **Loew T., Fichter K., Müller U., Schulz W., Strobel M.**,
Ansätze der Umweltkostenrechnung im Vergleich, UBA Texte, Berlin 2001
 - **Lucent Technologies – Bell Labs Innovations (1998):**
CARS MOC1. Cost Accounting Redesign Solution – Materials Only Costing 1. Introduction for Product Managers, Intern Draft: April 30, 1998 (Lucent Proprietary Information)
 - **Ludwig A.**,
Entwurf eines ökonomisch-ökologischen Rechnungswesens, Peter Lang Verlag, Frankfurt, 1999
 - **Mayer, Kram, Ludwig**,
Die Verbindung von Umweltbilanz und traditioneller betrieblicher Rechnungslegung zu einem Erweiterten Entscheidungsinstrument, Dresdner Beiträge zur Revision und Steuerlehre, Dresden, 1996
 - **Ökologisch Wirtschaften, Nr. 2/2000, April 2000, Hrsg.:**
Institut für ökologische Wirtschaftsforschung, IÖW, Berlin
 - **Savage, D.E. / White, A.L.**
Pollution Prevention Review, "New Applications of Total Cost Assessment: Exploring the Prevention – Production Interface", Winter 1995
 - **Schaltegger St., Burrit R.**
Corporate environmental Accounting: Issues, Concepts and Practices, Greenleaf, 2000
 - **Schaltegger St., Hahn T., Burrit R.**,
Environmental Management Accounting – Overview and main approaches, in Seifert, E., & Kreeb M., (Edt.), Environmental Management Accounting and the Role of Information Systems, Kluwer, The Netherlands, 2000
 - **Schaltegger St. / Müller, K.**
Environmental Management Accounting: Current Practice and Future Trends. Geographic Focus, Global. "Calculating the True Profitability of Pollution Prevention". Greener Management International, GMI 17 (Spring 1997)
 - **Schaltegger St., Müller K., Hindrichsen H.**,
Corporate Environmental Accounting, John Wiley & Sons, Chichester, 1996
 - **Schellhorn M.**,
Umweltrechnungslegung, Deutscher Universitäts Verlag, Wiesbaden, 1997
 - **Spitzer, M. / (1992):**
Calculating the Benefits of Pollution Prevention, in Pollution Engineering, 1 September 1992 pp. 33-38

- **Stahlmann V., Clausen J.,**
Umweltleistung in Unternehmen, Von der Öko-Effizienz zur Öko-Effektivität, Gabler Verlag, Wiesbaden 2000
- **Strobel, M. (2000):**
Systemisches Flussmanagement. Flussorientierte Kommunikation als Perspektive für eine ökologische und ökonomische Unternehmensentwicklung (Dissertationsschrift), Universität Augsburg 2000 (wird noch im Laufe dieses Jahres in Buchform veröffentlicht)
- **Strobel, M. / Enzler, S.**
"Drei auf einen Streich", Stoff- und Energieflussmanagement als Entwicklungsperspektive des Umweltmanagements, in: Ökologisches Wirtschaften 5/1997
- **Strobel, M. / Loew, T.**
Flusskostenmanagement. Ein neuer Ansatz zur systematischen Kostensenkung durch Umweltentlastung, in: Fichter, K. / Schneidewind, U. (Hg. 2000): Umweltschutz im globalen Wettbewerb. Neue Spielregeln für das grenzenlose Unternehmen, Berlin etc. (2000), Teil 3: Zukunftsmärkte und Wettbewerbsstrategien, S. 207-213
- **Strobel, M. / Wagner, F.**
Flusskostenrechnung als Instrument des Materialflussmanagements, in: UmweltWirtschaftsForum, 7. Jg., Heft 4-1999, S. 26-28.
- **Todd, R.**
"Zero-Loss Environmental Accounting Systems", in B.R.Allenby and D.J. Richards (eds.), The Greening of Industrial Ecosystems, National Academy Press, Washington, D.C., 1994. 191-200
- **Umweltstatistikgesetz, (UstaG),**
BGBl. 63 vom 28.9.1994, BGBl. 87 vom 29.12.1997, BRD
- **Umweltbundesamt/Bundesumweltministerium**
(Hrsg.), Handbuch Umweltcontrolling, Vahlen Verlag, München 1995
- **United Nations, Division for Sustainable Development,**
Improving Government's Role in the Promotion of environmental Managerial Accounting, New York, 2000
- **UNCTAD,**
United Nations Conference on Trade and Development, Accounting by small and medium sizes enterprises, Geneva, July 2000
- **UNCTAD,**
United Nations Conference on Trade and Development, Integrating Environmental and Financial Performance at the Enterprise level, A methodology for standardising Eco-efficiency indicators, Draft document
- **VDI, Verein Deutscher Ingenieure**
Ermittlung der Aufwendungen für Maßnahmen zum betrieblichen Umweltschutz, VDI 3800, 2000
- **Wagner, B. / Strobel, M. (1999):**
Kostenmanagement mit der Flusskostenrechnung, in: Freimann, J. (Hg. 1999): Werkzeuge erfolgreichen Managements. Ein Kompendium für die Unternehmenspraxis, Wiesbaden 1999, S. 49-70.
- **Wagner, B. (1995):**
Arbeitsmaterialien Umweltmanagement (Working Materials: Environmental Management) (Augsburg, Germany: Scriptorum 1995)
- **WBCSD, World Business Council for Sustainable Development, R. Bidwell, H. Verfaillie,**
Measuring Ecoefficiency, a guide to reporting company performance, www.wbcscd.ch/publications/measuring.htm
- **White, A. / Becker, M. / Goldstein, J. (1991):**
Total Cost Assessment: Accelerating Industrial Pollution Prevention through Innovative Project Financial Analysis (Sponsored by the US Environmental Protection Agency; Boston, MA: Tellus Institute, 1991)
- **White, A. (1991):**
EPA journal, "Accounting for Pollution Prevention", July-September (1993), pp. 23-25; White, A. / Becker, M. / Goldstein, J., Total Cost Assessment: Accelerating Industrial Pollution Prevention Through Innovative Project Financial Analysis, With Applications to the Pulp and Paper Industry, prepared for U.S. E.P.A, Office of Pollution Prevention, December 1991
- **White, A. / Becker, M. / Savage, D.S., (1993):**
Pollution Prevention Review, "Environmentally Smart Accounting: Using Total Cost Assessment to Advance Pollution Prevention" Summer 1993: 247-259