

Annual Report 2014



International Energy Agency

EBC Annual Report 2014

Energy in Buildings and Communities Programme

Published by AECOM Ltd on behalf of the International Energy Agency
Energy in Buildings and Communities Programme

© Copyright AECOM Ltd 2015

All property rights, including copyright, are vested in AECOM Ltd, which operates the EBC Executive Committee Support and Services Unit (ESSU), on behalf of the International Energy Agency: Energy in Buildings and Communities Programme.

In particular, no part of this publication may be reproduced, stored in a retrieval system or transmitted in any form or by any means, electronic, mechanical, photocopying, recording or otherwise, without the prior written permission of AECOM Ltd.

Published by AECOM Ltd, AECOM House, 63-77 Victoria Street, St Albans, Hertfordshire, AL1 3ER, United Kingdom.

Participating countries in EBC: Australia, Austria, Belgium, Canada, P.R. China, Czech Republic, Denmark, Finland, France, Germany, Greece, Italy, Ireland, Japan, Republic of Korea, The Netherlands, New Zealand, Norway, Poland, Portugal, Spain, Sweden, Switzerland, Turkey, United Kingdom and the United States of America.

Disclaimer Notice: This publication has been compiled with reasonable skill and care. However, neither AECOM Ltd nor the EBC Contracting Parties (of the International Energy Agency Implementing Agreement for a Programme of Research and Development on Energy in Buildings and Communities) make any representation as to the adequacy or accuracy of the information contained herein, or as to its suitability for any particular application, and accept no responsibility or liability arising out of the use of this publication. The information contained herein does not supersede the requirements given in any national codes, regulations or standards, and should not be regarded as a substitute for the need to obtain specific professional advice for any particular application. Views, findings and publications of the EBC IA do not necessarily represent the views or policies of the IEA Secretariat or of all its individual member countries.

Cover picture: Areal im Lenz, Switzerland
Source: Losinger Marazzi AG

Further copies may be obtained from:

EBC Bookshop
C/o AECOM Ltd
Colmore Plaza
Colmore Circus Queensway
Birmingham B4 6AT
United Kingdom
www.iea-ebc.org
essu@iea-ebc.org

Contents

- 5 Chair's Statement
- 6 Latest Outcomes for Policy and Decision Makers
- 9 NEW RESEARCH PROJECTS**
- 10 Strategy and Practice of Adaptive Thermal Comfort in Low Energy Buildings
- 12 Design and Operational Strategies for High Indoor Air Quality in Low Energy Buildings
- 14 Energy Flexible Buildings
- 17 ONGOING RESEARCH PROJECTS**
- 18 Definition and Simulation of Occupant Behavior in Buildings
- 20 Long-Term Performance of Super-Insulating Materials in Building Components and Systems
- 21 LowEx Communities – Optimised Performance of Energy Supply Systems with Exergy Principles
- 22 Implementation of Energy Strategies in Communities
- 24 Ventilative Cooling
- 26 Business and Technical Concepts for Deep Energy Retrofits of Public Buildings
- 28 New Generation Computational Tools for Building and Community Energy Systems
- 30 High Temperature Cooling and Low Temperature Heating in Buildings
- 32 Reliable Building Energy Performance Characterisation Based on Full Scale Dynamic Measurement
- 34 Evaluation of Embodied Energy and CO₂ Equivalent Emissions for Building Construction
- 36 Cost Effective Energy and Carbon Dioxide Emissions Optimization in Building Renovation
- 38 Reliability of Energy Efficient Building Retrofitting – Probability Assessment of Performance and Cost
- 40 Air Infiltration and Ventilation Centre AIVC
- 42 COMPLETED RESEARCH PROJECTS**
- 43 Integration of Micro-Generation and Related Energy Technologies in Buildings
- 45 Towards Net Zero Energy Solar Buildings
- 47 BACKGROUND INFORMATION**
- 48 EBC and the IEA
- 51 Recent Publications
- 52 EBC Executive Committee Members
- 53 EBC Operating Agents
- 52 Past Projects

Chair's Statement

In 2014, the IEA-EBC Programme made significant outreach efforts to promote our international collaborative R&D work. This began in March, when we presented a webinar 'Achieving Near-Zero Energy Use through Open Innovation', jointly organised with the European portal for energy efficiency in buildings, BUILD UP. This provided an opportunity for the extensive BUILD UP community to find out about EBC's ambitious R&D efforts and to learn from us how to develop initial concepts into major international R&D projects.

In April, at a workshop on 'Energy Efficient and Intelligent Transport Systems' convened by the R&D programmes within the IEA's Transport Contact Group, we examined common concerns. We concluded that to achieve global goals more emphasis should be placed on system wide reductions of energy demand and greenhouse gas emissions, due to the integrated nature of cities and communities including transportation and industry. Strategies to reach these goals are being developed in our project 'Annex 63: Implementation of Energy Strategies in Communities', who participated in the workshop.

Our report, 'Methodology for Cost-Effective Energy and Carbon Emissions Optimization in Building Renovation', was delivered in May to the European Commission's DG Energy to assist implementation of the Energy Performance in Buildings Directive Recast. This report intended to underpin future standards by providing an innovative calculation method is a key deliverable from our project, 'Annex 56: Cost Effective Energy and Carbon Dioxide Emissions Optimization in Building Renovation'.

In November, our project 'Annex 61: Business and Technical Concepts for Deep Energy Retrofit of Public Buildings' organized the BPIE hosted event, 'Investing into Energy Efficiency Projects: Why and How?'. Its goal was to demonstrate that improving energy efficiency in public buildings can be an attractive business model for commercial service providers, private banks or

investment funds. The speakers took into consideration policy guidance, experiences from current energy savings projects and risk analysis related to energy-savings companies. Excellent attendance and positive feedback received showed that this responded to a real market need.

In line with our current Strategic Plan, in 2014 we have launched three new projects, 'Annex 67: Energy Flexible Buildings' is exploring the possibilities for and limits of individual buildings and clusters of buildings in better balancing unpredictable renewable energy production and loads on electricity grids. Meanwhile, Annex 68 deals with 'Design and Operational Strategies for High Indoor Air Quality in Low Energy Buildings', and Annex 69 is concerned with 'Strategy and Practice of Adaptive Thermal Comfort in Low Energy Buildings'.

The Republic of Singapore joined our November Executive Committee Meeting as observers, as part of their evaluation process towards joining the EBC Programme. I will be delighted if they decide to join us, testifying to the value that we offer. And, this highlights that to be attractive for such potential new member countries with hot and humid climatic zones we need to address relevant research topics.



Andreas Eckmanns
EBC Executive Committee Chair

Latest Outcomes for Policy and Decision Makers

The aim of this section is to inform policy and decision makers about any final or interim project deliverables, key findings and insights, or events arranged by the IEA-EBC Programme that may be of particular interest to their areas of work. More information on the projects mentioned is provided later within this Annual Report.

Life cycle energy and grid impacts for net zero energy buildings

A key output from the recently completed research project, 'Annex 52: Towards Net Zero Energy Solar buildings', was assessments of life cycle energy (LCE) for net zero energy buildings (NZEBs) in comparison with low energy or Passivhaus buildings. An important policy question for new buildings is how to balance the embodied energy of construction products and materials with savings in use over the building lifetime, and whether or not there is a point beyond which limits on energy in use actually increase rather than reduce the LCE. This project produced a LCE literature review and synthesised over 150 NZEB case studies. This included an analysis of 11 Minergie A-certified low energy residential buildings

in Switzerland, which found that a move to NZEB could reduce LCE, in primary energy terms, by about 60% compared to a low energy building.

As well as highly useful information and feedback on NZEB case studies world-wide, the project outputs also included analysis on and indicators for the interactions between NZEBs and the local electricity grid. In addition to helping to define what the key metrics could be for designers to assess local grid impacts, a crucial project outcome is the realisation that in future urban planners and grid network operators will need to work together more closely, if the full benefits of decentralised energy generation and demand response are to be realised.

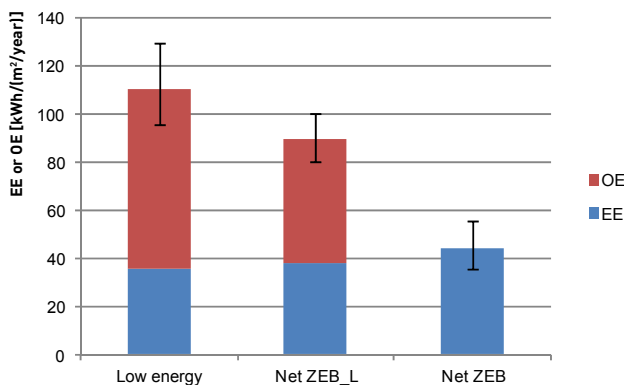

Mean values of embodied energy (EE), operating energy (OE) and the variation of life cycle energy use (non-renewable primary energy), comparing three different building standards. Source: EBC Annex 52

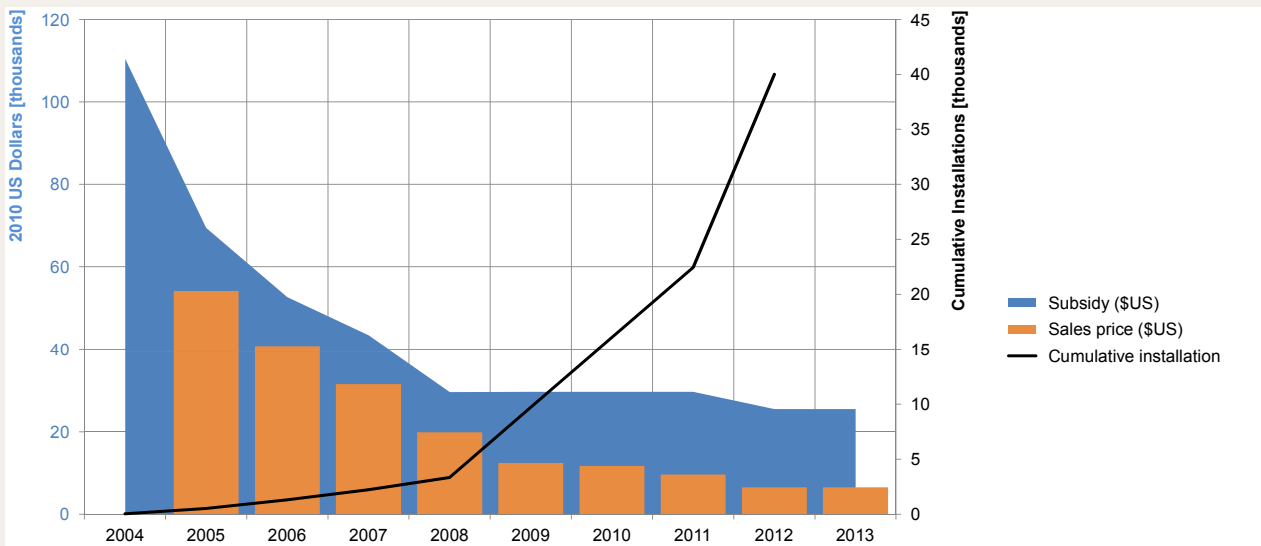

Historical selling price, government subsidy, and cumulative number of installations for micro-cogeneration systems in Japan.
Source: EBC Annex 54

Real World Energy Savings from Micro-Generation in Buildings

The other research project completed in 2014, 'Annex 54: Integration of Micro-Generation and Related Energy Technologies in Buildings', has a number of outputs that will be of interest to policymakers. One relates to the maturation of gas fuelled micro- and mini-CHP (combined heat and power) systems, covering internal combustion engines, fuel cells and Stirling engines. These technologies have significant growth potential for deployment at residential and non-residential scales to provide decentralised heat and electricity generation. However, their economic and carbon performance is sensitive to their electrical efficiency, matching to daily heat demands and the extent to which the electricity can be used on site. This project has provided greater insight into the real world performance of these different

technologies, both from simulations and from data from field trials, concluding that they can save between 5% - 20% in primary energy and carbon emissions. It has also been able to track the progress of technology development over the four years of the project, during which there has been significant technological commercialisation and uptake, with for example, 40000 fuel cell micro-CHP units installed in Japan by the end of 2012.

The project has also provided a fascinating snapshot of the range of different market support mechanisms used in industrialised countries to support microgeneration and the impacts they have had on financial viability and uptake.

Energy in Buildings and Communities Programme

May 2014



EBC is a programme of the International Energy Agency (IEA)



One of the outcomes from EBC Annex 56 is a compilation of a set of 'Shining Examples' identified by the project participants.

Optimising cost, energy and carbon savings in residential building renovation

The ongoing research project 'Annex 56: Cost Effective Energy and Carbon Dioxide Emissions Optimisation in Building Renovation' is assessing the balance point, in terms of costs and benefits, between energy efficiency measures and the use of renewable energy when planning major building renovations. In the past year, the project has published a collection of detailed case studies (called 'Shining Examples') of renovation projects of residential buildings from six different countries. These interesting case studies provide some useful examples and in depth information on the types of measures used (combining energy efficiency and renewable or low carbon energy), the energy and carbon savings achieved and the financial costs and benefits. The case studies also include occupant feedback, and explore some of the 'co-benefits' arising from the renovations such as improved comfort, reduced noise and so on.

The same project has also produced a methodology report, presenting the results of generic modelling of the cost-benefit performance of ten different packages of renovation measures, on residential buildings in the market context of each of the seven participating countries. One key conclusion for policy makers is that targets for renovation of existing buildings should not consider only reducing energy use, but should be used in combination with targets for reducing carbon emissions, to facilitate the role of cost effective renewable energy solutions as part of such renovations.

Stephen Ward and Malcolm Orme
EBC Executive Committee Support and Services Unit (ESSU)
essu@iea-ebc.org

New Research Projects

—————
**STRATEGY AND PRACTICE OF ADAPTIVE THERMAL COMFORT
IN LOW ENERGY BUILDINGS (ANNEX 69)**

—————
**DESIGN AND OPERATIONAL STRATEGIES FOR HIGH INDOOR AIR QUALITY
IN LOW ENERGY BUILDINGS (ANNEX 68)**

—————
**ENERGY FLEXIBLE BUILDINGS
(ANNEX 67)**

Strategy and Practice of Adaptive Thermal Comfort in Low Energy Buildings

ANNEX 69

For the buildings sector globally, reducing energy consumption and providing comfortable indoor environments for occupants are both important tasks. However, it is challenging to find a good balance between these two issues. The key point is to understand the actual thermal requirements of occupants. Previous research on adaptive thermal comfort has revealed it is not necessary to continuously maintain a steady indoor thermal environment with mechanical cooling or heating. Resources such as natural ventilation can play a role in achieving thermal comfort, so also reducing energy consumption. Besides this, the opportunity for control by occupants was found to have a positive impact, enhance people's satisfaction with their indoor thermal environment.

At present, there are still certain problems to be solved in this field. Although the adaptive effect has been recognized, the mechanism of the adaptive process is still

unclear. Furthermore, adaptive mechanisms of people in diverse climatic regions can be quite different, which may result in different building design strategies and indoor environment solutions. Current understanding of this issue is still limited. And, apart from purely free-running buildings and purely air-conditioned buildings, mixed-mode buildings (cooling or heating together with natural ventilation) are actually the most common cases. However, there are no evaluation criteria for this kind of building in existing standards. Most clients refuse to accept low energy building designs with indoor thermal environments beyond the comfort ranges in current standards.



A typical mixed-mode building. The auditorium was designed with openable walls to make good use of natural ventilation. This space has achieved good thermal comfort and low energy consumption.
Source: Shenzhen iBR, P.R. China

Objectives

The project objectives are to:

- establish a database with quantitative descriptions of occupant thermal adaptation responses,
- develop new or improved indoor thermal environment criteria based on the adaptive thermal comfort concept
- provide a basis for the creation of or revisions to indoor environment standards,
- propose passive building design strategies to achieve thermal comfort with low energy consumption, and
- provide guidelines for new cooling and heating devices based on perceived or individual control adaptation.

Deliverables

The following project deliverables are planned:

- a database including information about human thermal responses, together with their behaviour and energy consumption,
- a modified adaptive thermal comfort model,
- criteria to be developed for adaptive thermal comfort in the indoor environment,
- guidelines for low energy building design based on the adaptive thermal comfort concept, and
- guidelines for low energy cooling and heating devices that provide individual or local environmental control.

Progress

The project was formally approved in November 2014 with a one year preparation phase.

Meetings

- An international workshop to establish the new database of thermal comfort research took place in Seoul, Republic of Korea, in February 2014.
- International workshops to further develop the project proposal took place in Windsor, UK, in April 2014, and in Hong Kong, in July 2014.

Project duration

2014 - 2018

Operating Agent

Prof. Yingxin Zhu, Tsinghua University, China

Co-Operating Agent: Richard de Dear, Sydney University, Australia

Participating countries (provisional)

Australia, P.R. China, Denmark, Germany, Japan, Republic of Korea, The Netherlands, UK, USA

Observer: Singapore

Further information

www.iea-ebc.org

Design and Operational Strategies for High Indoor Air Quality in Low Energy Buildings

ANNEX 68

To achieve nearly net zero energy use, all buildings in future will need to be more efficient and optimized. As new buildings are already well insulated in certain industrialised countries, the focus is shifting to limiting space heating energy consumption by reducing ventilation demand. Low energy buildings need to be airtight and energy demand for ventilation is often reduced by lowering the ventilation rate to the minimum necessary. Each of these can have adverse impacts on indoor air quality (IAQ). This project is therefore investigating how to ensure that future low energy buildings are able both to improve their energy performance and to provide comfortable and healthy indoor environments. The project is focusing on design options and operational

strategies that might be used to enhance the energy performance of buildings, such as demand controlled ventilation, improvement of the building envelope by tightening and selecting better insulating products. These methods will be investigated to analyse possible effects on IAQ and to determine optimal solutions. High IAQ and low energy buildings can only be achieved by carrying out a multi-faceted optimization process. Therefore, the project will deal with and combine elements of knowledge that are themes of work from other EBC projects, regarding ventilation, chemical emissions from building products, hygrothermal conditions in buildings and their materials, and building simulation.

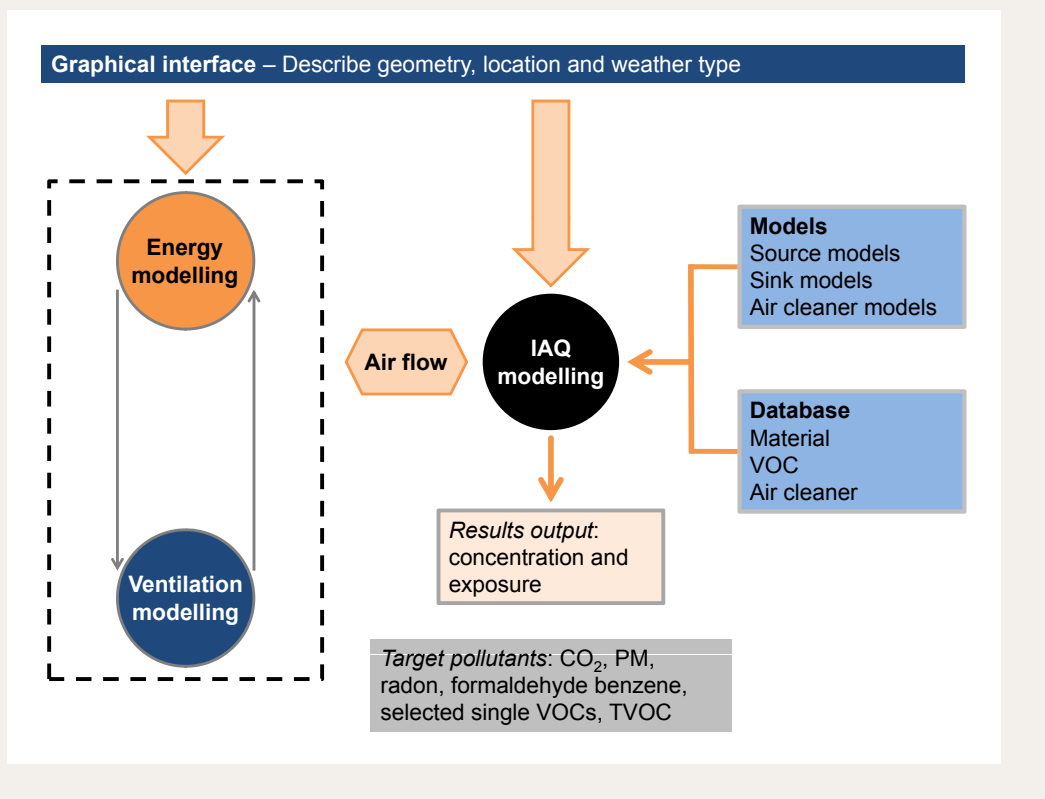

Outline of a suggested package of tools to combine energy and ventilation modelling with indoor air quality (IAQ) analysis
Source: Tsinghua University, P.R. China

Objectives

The key project objectives are to:

- develop design and operational strategies for energy efficient buildings that will not compromise the IAQ. Operational parameters that will be dealt with will comprise of, but will not be limited to the means for ventilation and its control, thermal and moisture control and air purification strategies and how they can be optimally combined,
- set up metrics for required performance that combine the aspiration for very high energy performance with good IAQ,
- identify or further develop the tools that will assist building designers and managers to improve building energy performance and to provide comfortable and healthy indoor environments,
- gather existing or provide new data about indoor pollutants and their properties pertaining to heat, air and moisture transfer that are needed for the above analyses, and
- identify and investigate relevant case studies, in which the above mentioned performance can be examined and optimized.

Deliverables

The following project deliverables are planned:

- guidelines and procedures on how to continually control the necessary ventilation in a building such that the indoor air quality is good in occupied hours, and while the energy consumption is kept at a minimum,
- an overview of databases containing information about pollutants in buildings, including those pertaining to the emission of volatile organic compounds (VOCs),
- an overview of contemporary tools for combined prediction of the energy situation of buildings, which also considers the emission, transport and storage of possible pollutants in buildings, and

- a database of documented case studies and demonstration projects where the ventilation has been varied by only the necessary amount to ensure proper dilution of indoor pollution sources.

Progress

The project was approved in November 2014 to start a one year preparation phase.

Meetings

A project preparation workshop was held in Shenzhen, China, in July 2014.

Project duration

2014 - 2019

Operating Agent

Carsten Rode, Technical University of Denmark, Denmark

Participating countries (provisional)

Austria, Canada, P.R. China, Czech Republic, Denmark, France, Germany, Japan, The Netherlands, Norway, Portugal, Sweden, USA

Observer: Brazil

Further information

www.iea-ebc.org

Energy Flexible Buildings

ANNEX 67

The energy flexibility of a building is defined as its ability to manage energy demand and generation according to local climatic conditions, occupant needs and energy grid requirements. Energy flexible buildings will therefore allow for demand side management and load control to shift demands over time and thereby demand response based on the requirements of the surrounding energy grids. Moreover, they may play an important role in facilitating energy systems based entirely on renewable sources, particularly by supporting grid stabilisation. If they account for a high percentage of total generation, renewable energy sources, such as wind and solar power, have an intrinsic variability that can seriously affect the stability of energy grids.

All buildings have thermal mass embedded in their constructions, which makes it possible to store a certain

amount of heat. As an example of demand shifting, depending on the amount, distribution, speed of charging and discharging of the thermal mass, it is possible to postpone active heating or cooling for a certain period without compromising thermal comfort in the building. And if, prior to the shutdown of the heating or cooling system, the thermal mass is highly pre-heated or pre-cooled, but still within the comfortable room temperature range, it may be possible to prolong the shutdown period itself.

Many buildings already contain different kinds of discrete forms of energy storage that may add to energy demand flexibility. One such typical form of storage is the domestic hot water tank, which might be pre-heated to excess before an anticipated low demand situation. The excess heat may then be utilized for space heating, but could

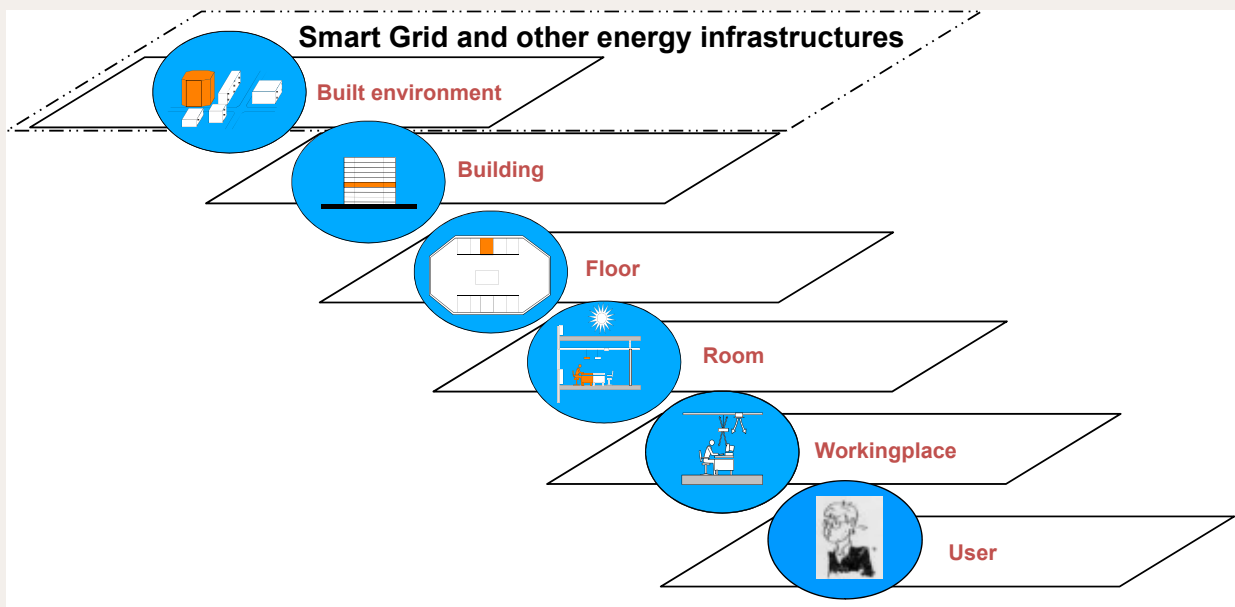

Energy Flexibility may be obtained at different levels in buildings, but should never compromise occupant comfort. Energy grids 'see' the aggregated flexibility of several buildings, rather than the flexibility of each individual building.

Source: Prof. Wim Zeiler, Technische Universiteit Eindhoven

also be used for white goods such as hot-fill dishwashers, washing machines and tumble dryers to decrease and shift their electricity needs. But, there is currently little insight as to how much flexibility different types of building may be able to offer to future energy systems. The aim of the project is thus to increase knowledge, to demonstrate whether energy flexible buildings can support energy grids, and to identify critical aspects and possible solutions to manage energy flexibility.

The project beneficiaries will be:

- the building research and education communities,
- district system operators (DSOs), transmission system operators (TSOs) and aggregators,
- architects and design companies, engineering offices and consultants,
- building component, HVAC-system and controls developers and manufacturers, and
- policy and decision makers and their advisors involved in shaping future energy systems.

Objectives

The project objectives are:

- the development of common terminology, a definition of 'energy flexibility in buildings' and a classification method,
- investigation of user comfort, motivation and acceptance associated with the introduction of energy flexibility in buildings,
- investigation of the energy flexibility potential in different buildings and contexts, and development of design guidelines, control strategies and algorithms,
- investigation of the aggregated energy flexibility of buildings and the potential effect on energy grids, and
- demonstration of energy flexibility through experimental and field studies.

Deliverables

The following project deliverables are planned:

- a source book containing major findings from the project,
- a report on control strategies and algorithms,
- a report on test procedures and results from laboratory and full scale tests,
- a report with guidelines for monitoring of buildings, and
- articles on terminology with a definition of energy flexibility in buildings, indicators for characterization of energy flexibility in buildings, and occupant perspectives.

Progress

The project working phase was approved in June 2014.

Meetings

- A project definition workshop took place in Copenhagen, Denmark, in March 2014.
- The 1st working phase meeting took place in Basel, Switzerland, in September 2014.

Project duration

2014 – 2019

Operating Agent

Søren Østergaard Jensen, Danish Technological Institute, Denmark

Participating countries (provisional)

Austria, Belgium, Canada, Czech Republic, Denmark, Finland, Germany, Italy, The Netherlands, Norway, Portugal, Spain, Sweden, Switzerland, UK

Further information

www.iea-ebc.org

Ongoing Research Projects

DEFINITION AND SIMULATION OF OCCUPANT BEHAVIOR IN BUILDINGS
(ANNEX 66)

LONG-TERM PERFORMANCE OF SUPER-INSULATING MATERIALS
IN BUILDING COMPONENTS AND SYSTEMS (ANNEX 65)

LOWEX COMMUNITIES – OPTIMISED PERFORMANCE OF
ENERGY SUPPLY SYSTEMS WITH EXERGY PRINCIPLES (ANNEX 64)

IMPLEMENTATION OF ENERGY STRATEGIES IN COMMUNITIES (ANNEX 63)

VENTILATIVE COOLING (ANNEX 62)

BUSINESS AND TECHNICAL CONCEPTS FOR
DEEP ENERGY RETROFITS OF PUBLIC BUILDINGS (ANNEX 61)

NEW GENERATION COMPUTATIONAL TOOLS
FOR BUILDING AND COMMUNITY ENERGY SYSTEMS (ANNEX 60)

HIGH TEMPERATURE COOLING AND
LOW TEMPERATURE HEATING IN BUILDINGS (ANNEX 59)

RELIABLE BUILDING ENERGY PERFORMANCE CHARACTERISATION
BASED ON FULL SCALE DYNAMIC MEASUREMENT (ANNEX 58)

EVALUATION OF EMBODIED ENERGY AND CARBON DIOXIDE
EQUIVALENT EMISSIONS FOR BUILDING CONSTRUCTION (ANNEX 57)

COST EFFECTIVE ENERGY AND CARBON DIOXIDE EMISSIONS
OPTIMIZATION IN BUILDING RENOVATION (ANNEX 56)

RELIABILITY OF ENERGY EFFICIENT BUILDING RETROFITTING –
PROBABILITY ASSESSMENT OF PERFORMANCE AND COST (ANNEX 55)

AIR INFILTRATION AND VENTILATION CENTRE AIVC (ANNEX 5)

Definition and Simulation of Occupant Behavior in Buildings

ANNEX 66

Understanding and accurately quantifying the impact of energy-related occupant behaviour (OB) is critical for energy efficient design, operation, and retrofit of buildings. Examples of energy-related behaviours include adjusting thermostats for comfort, switching lights on and off, opening and closing windows, pulling up and down window blinds, and moving between spaces. Currently, OB is insufficiently recognised and understood leading to oversimplified assumptions. Even for designs assumed to be optimized in terms of building energy performance, this leads to unfulfilled expectations and large discrepancies between simulated and real performance.

This project is therefore focusing on capturing and quantifying the impacts of OB on building energy performance. The main aim is to identify and eliminate current inconsistencies in building energy simulation by developing standardized definitions, frameworks and modelling methodologies. These solutions require a multidisciplinary approach for understanding and properly characterizing the impact of OB on building energy consumption. Another top priority is to foster international collaboration, and in the spirit that an OB framework will be universally adopted, the models will be integrated into a coherent whole and efforts will be channelled where most needed. The overall goal is to

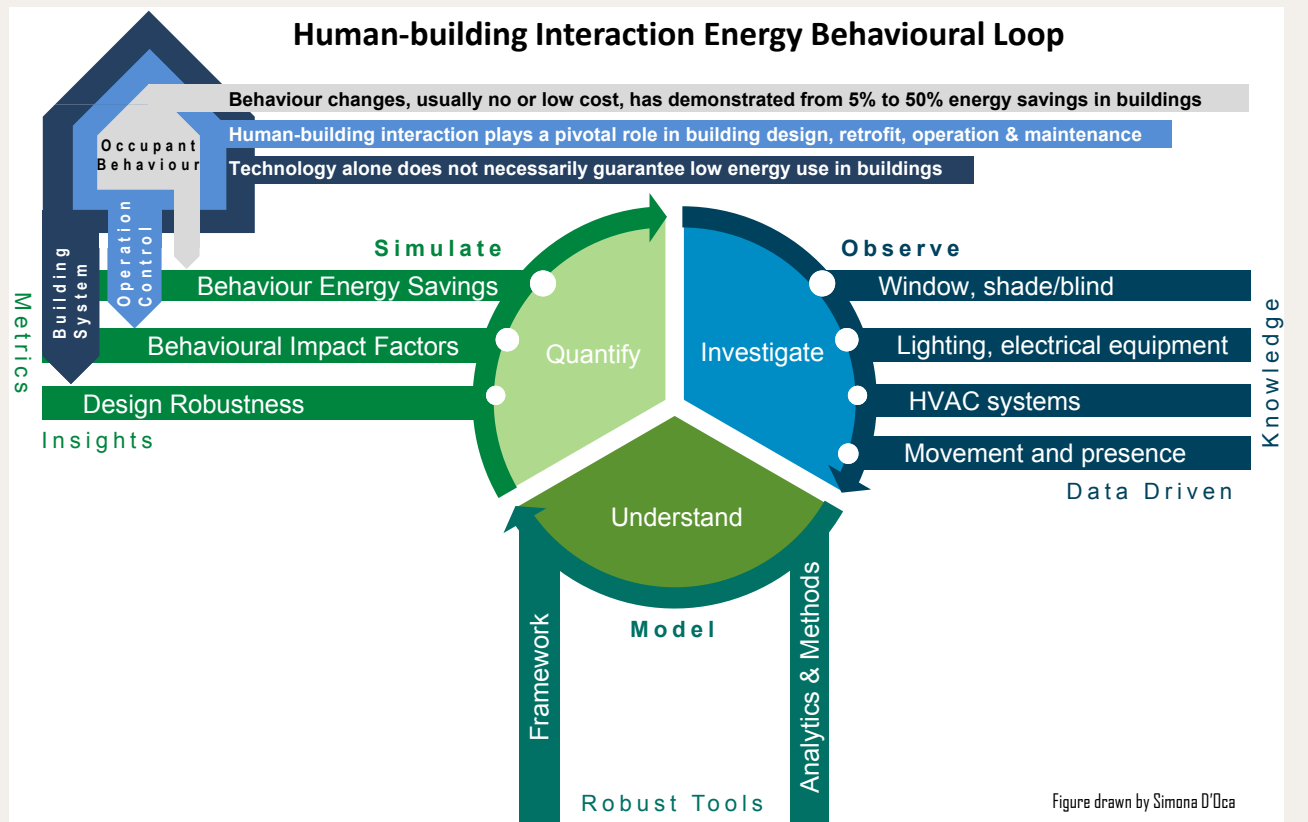

The human-behavior interaction energy behavioural loop capturing the methodology for occupant behaviour research
 Source: EBC Annex 66

provide recommendations on integrating OB into building energy codes and standards, such as ASHRAE Standard 55, Energy Standards 90.1 and 90.2, and Ventilation Standards 62.1 and 62.2.

Objectives

The overall project objective is to address the following fundamental research question: How should quantitative descriptions of occupant behaviour be developed in order to analyse and evaluate its impact on building energy consumption? The specific objectives are to:

- identify quantitative descriptions and classifications for energy-related OB in buildings,
- develop adequate calculation methodologies for OB,
- implement OB models with building energy simulation tools, and
- demonstrate OB models in building design, evaluation and operation optimization by case studies.

Deliverables

The following project deliverables are planned:

- a standard definition and simulation methodology for occupant presence and movement models,
- guidelines for behavioural data collection using systematic measurement, modelling and validation approaches,
- an occupant behaviour XML schema, a software module that can be integrated within building energy modelling programs, a software developers guide and sample computer codes to demonstrate the use of the schema and module,
- a report on the methodologies to develop and validate OB models, and
- a report on the application of OB models.

Progress

Commencement of the project working phase was formally approved in November 2014.

Meetings

- The 1st Open Forum and Experts Meeting took place in Hong Kong, P.R. China, in March 2014.
- The 2nd Open Forum and Experts Meeting took place in Nottingham, United Kingdom, in August 2014.

Project duration

2013–2017

Operating Agent

Da Yan, Tsinghua University, P.R. China, and
Tianzhen Hong, Lawrence Berkeley National Laboratory, USA

Participating countries

Austria, Canada, P.R. China including Hong Kong S.A.R.,
Denmark, Italy, The Netherlands, Poland, Spain, USA

Further information

www.iea-ebc.org

Long-Term Performance of Super-Insulating Materials in Building Components and Systems

ANNEX 65

The earlier EBC project, 'Annex 39: High Performance Thermal Insulation Systems' showed that vacuum insulation panel (VIP) products have reached a level of quality that customers can trust for specific applications under well-defined conditions. However, there is still a need for design and calculation methods, testing and assessment procedures to characterize the suitability of new super-insulating materials (SIMs) for wider application in practice. Actually, overall performance and durability of SIMs must be investigated when operating conditions are more severe (high temperature or humidity). Furthermore, guidelines for design, installation and inspection must be also provided. Finally, new types of SIMs are being released on the market and their durabilities and applicabilities need to be scientifically determined.

Objectives

The project objectives are to:

- understand the state-of-the-art on the development of SIMs and their applications in the buildings sector,
- develop experimental and numerical tools to provide reliable data (properties and durability) for the supply chain,
- write guidelines for design and secure installation of

components and systems including SIMs, especially for retrofitting,

- support standardization and assessment procedures, and
- extend end user knowledge and increase their confidence in using SIMs by applying sustainability analysis.

Deliverables

The following project deliverables are planned:

- a report on the state-of-the-art for SIMs, components and systems integrating them and relevant case studies,
- scientific information on how to assess SIMs through reliable testing and ageing methods,
- guidelines for design, installation and inspection based on case studies, and
- a report on sustainability aspects of SIMs.

Progress

Approval was granted in June 2014 to proceed with the project working phase.

Meetings

- The 1st project meeting took place in Grenoble, France, in September 2014.



Application of Aerogel Mortar Rendering
Source: EMPA

Project duration

2013–2017

Operating Agent

Daniel Quenard, CSTB, France

Participating countries

Belgium, Canada, P.R. China, France, Germany, Italy, Japan, Republic of Korea, Norway, Spain, Switzerland, Sweden, Observer: Israel

Further information

www.iea-ebc.org

LowEx Communities – Optimised Performance of Energy Supply Systems with Exergy Principles

ANNEX 64

At the community level, different renewable energy sources are available to supply heating and cooling energy demands for buildings. These are characterised by differing quality, expressed as their exergy levels. The higher the exergy level, the higher temperature can be produced from the energy source. For example, electricity from photovoltaic generation has a high exergy level and low temperature heat from some renewable energy sources or from waste heat has a low exergy level. Low quality energy is particularly interesting, because low exergy ('LowEx') supply is very efficient. However, to understand how to best use this for community energy systems presents a major challenge. To solve this, the identification of potential savings and synergies by performing holistic analysis of energy flows is necessary.

The application of exergy analysis principles is especially important, allowing the detection of the various energy quality levels available and the identification of optimal contributions to efficient supplies. From this, appropriate strategies and technologies with great potential can be derived for promoting the use of LowEx energy sources with a high share of renewable energy for heating and cooling, even of entire cities.

Within this project, advanced technologies are being identified to realise the full potential of LowEx systems. The aim is to develop the necessary knowledge, tools and networks to demonstrate LowEx thinking at a community scale, with the goal of finding cost effective solutions to achieving 100% renewable and GHG emissions-free energy systems.

Objectives

The project objectives are to:

- increase the overall energy and exergy efficiency of community systems,
- identify and develop promising LowEx technical solutions and practical approaches to future network management,

- identify business models for distribution and operation,
- develop assessment methods and tools for various stages of planning, and
- transfer knowledge to community stakeholders.

Deliverables

The following project deliverables are planned:

- an easy to understand, practical and applicable design guidebook for key stakeholders within communities,
- holistic balancing methods and tools to display various stages of planning and design of buildings, groups of buildings and community energy supply systems, and
- a project website and communication platform making use of local networks and energy-related associations.

Progress

During the project meetings the collaborative work was initiated aiming to identify holistic and innovative approaches to community energy supply systems. Many ideas, inputs and example of previous work were collected, so improving the basis of the project.

Meetings

- The 2nd meeting for the preparation phase took place in Vienna, Austria in April 2014.
- The 1st meeting for the working phase took place in Reykjavik, Iceland in August 2014.

Project duration

2013–2017

Operating Agent

Dietrich Schmidt and Christina Sager, Fraunhofer Institute for Building Physics IBP, Kassel, Germany

Participating countries

Austria, Denmark, Germany, The Netherlands, Japan, Sweden, Switzerland, USA

Further information

www.iea-ebc.org

Implementation of Energy Strategies in Communities

ANNEX 63

Cities consume the major part of energy production worldwide and account for a roughly equal share of global greenhouse gas (GHG) emissions. Consequently, to mitigate climate change and energy shortages, a drastic reduction of both energy and GHG emissions is essential for largescale progress towards more sustainable cities and communities.

In the past, research in the buildings sector has generally focused on technological innovation and improvements at the scale of the individual building. But, it is widely accepted that due to the integrated nature of our cities, including transportation and industry, to achieve the

global goals more emphasis should be placed on system wide reductions of energy demand and related GHG emissions and higher shares of renewable energy supplies. The required transition needs to refocus away from optimisation of building components via single buildings to optimised solutions for whole neighbourhoods and communities.

A first analysis of bottlenecks carried out with the participation of urban planners showed that there are also several barriers to overcome: Unclear or fragmented municipal strategies, missing guidance on stakeholder involvement or focusing only on financial



Areal im Lenz, Switzerland
Source: Losinger Marazzi AG

benefits are some of the obstacles to successful implementation of energy strategies in communities. But, early experiences in the development of net zero energy communities have revealed not only challenges, but also significant opportunities emerging that support net zero energy community concepts, including increased budgets for investments derived from energy savings, increased comfort and quality of life, and local production that boosts local economies. The frontrunners show that integrated approaches can be beneficial for all stakeholders, especially the end users, as well as the general population.

Objectives

The overall objective is to give recommendations on procedures for implementation of optimised energy strategies at the community scale. In particular, the specific objectives are to:

- develop recommendations for implementation of optimized energy strategies at the scale of communities,
- develop recommendations for effective translation of a city's energy and CO₂ reduction goals to the community scale,
- develop recommendations for optimization of policy instruments for the integration of energy and CO₂ reduction goals into common urban planning processes,
- develop new techniques for stakeholder cooperation along with holistic business models involving a wide range of stakeholders,
- devise methods for monitoring and evaluation, and
- involve cities and urban planners in order to integrate energy planning into urban planning procedures.

Deliverables

The following project deliverables are planned:

- implementation methodology report for energy strategies for communities,
- report on planning process,
- documentation of case studies,
- documentation of national workshops and involvement of cities,
- working material to meeting cities' needs (posters, model presentations, leaflets), and
- an expert group summary on recommended best practices.

Progress

The start of the project working phase was agreed in June 2014.

Meetings

- The 1st project meeting took place in September 2014 in Dublin, Ireland.

Project duration

2013–2017

Operating Agent

Helmut Strasser, Salzburg Institute for Regional Planning and Housing (SIR), Austria

Participating countries

Austria, Belgium, Canada, Denmark, France, Germany, Ireland, Japan, The Netherlands, Sweden, Switzerland, USA

Further information

www.iea-ebc.org

Ventilative Cooling

ANNEX 62

The current trend in building energy efficiency towards nearly zero energy buildings creates a number of new challenges for building design and construction. One of the major challenges is the increased need for cooling in highly insulated and airtight buildings, which is not only required in summer and mid season periods, but can also be needed in winter, particularly in office buildings. Most of the post-occupancy studies of high performance buildings in European countries show that summer temperatures being too high is the problem most often reported, especially in residential buildings.

Ventilative cooling refers to the use of natural or mechanical ventilation strategies to cool indoor spaces. This effective use of outside air reduces energy used by mechanical cooling, while giving a comfortable thermal environment. The most common technique is the use

of increased daytime ventilation airflow rates and night ventilation, but other technologies may also be considered. Ventilative cooling can be an attractive and energy efficient passive solution to avoid overheating because:

- ventilation is already provided in most buildings through mechanical systems or natural systems using opening windows,
- ventilative cooling can remove excess heat gains and increase air speeds, so improving the thermal environment, and
- the possibilities for using the free cooling potential of low temperature outdoor air increases considerably as cooling becomes required outside of the usual summer period.

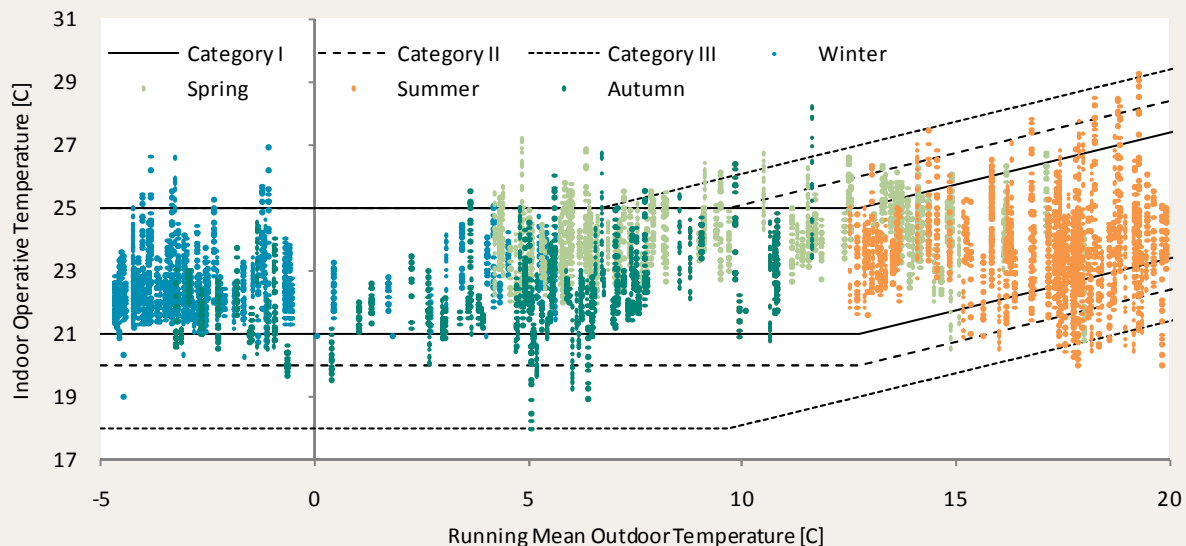

The operative temperature in the living room in a zero energy residential building, 'Home for Life', constructed in Lystrup, Denmark is shown as a function of the running mean outdoor temperature. The measurements were recorded during the first year of building operation. The results show that operative temperatures in the winter are at similar levels to those in the spring, summer and autumn. Source: Velux

To address the cooling challenges of buildings, this project is focusing on the development of design methods and compliance tools related to predicting, evaluating and eliminating cooling need and the risk of overheating in buildings, and on the development of new attractive energy efficient ventilative cooling solutions.

Objectives

The project objectives are to:

- analyse, develop and evaluate suitable design methods and tools for prediction of cooling need, ventilative cooling performance and risk of overheating in buildings;
- give guidelines for integration of ventilative cooling in energy performance calculation methods and regulations, including specification and verification of key performance indicators;
- develop recommendations for flexible and reliable ventilative cooling solutions that can create comfortable indoor conditions under a wide range of climatic conditions;
- demonstrate the performance of ventilative cooling solutions through analysis and evaluation of well documented case studies.

Deliverables

The following project deliverables are planned:

- an overview and state of the art report on ventilative cooling,
- a ventilative cooling source book,
- ventilative cooling case studies,
- guidelines for ventilative cooling design and operation, and
- recommendations for legislation and standards.

Progress

During 2014, a first draft of the state of the art report on ventilative cooling and a case study template were completed.

Meetings

- The 1st Expert Meeting took place in Lausanne, Switzerland, in April, 2014.
- The 2nd Expert Meeting took place in Uxbridge, United Kingdom, in September 2014.

Project duration

2013–2017

Operating Agent

Per Heiselberg, Aalborg University, Denmark

Participating countries

Austria, Belgium, P.R. China, Denmark, Finland, Greece, Ireland, Italy, Japan, The Netherlands, Norway, Switzerland, Sweden, UK, USA

Further information

www.iea-ebc.org

Business and Technical Concepts for Deep Energy Retrofits of Public Buildings

ANNEX 61

Know how and available funding are both crucial for the implementation of refurbishment strategies for ambitious reduction targets for energy use in government and public buildings. This combination may lead to a range of contract based 'business models' to be applied. However, recent research has shown that the performance of the 'owner directed' business model for energy retrofit projects has not kept pace with new requirements to increase the number and pace of energy retrofits to improve the efficiency of existing buildings to an adequate level. For the most part, owner directed business models lack the stimulation to meet energy efficiency targets at fixed levels of investment.

In recent years, energy savings performance contracting (ESPC) has proven to be a very successful business model overcoming the weak points of owner directed models: ESPC business models can stimulate both contracting parties to achieve high cost effectiveness in terms of the savings to investment ratio, a better life cycle cost effectiveness and a high degree of energy efficiency. The

ESPC business model structure typically sees an Energy Service Company providing the planning, implementation and funding of the investment, with the customer paying for the contract over its term through the energy cost savings achieved. To date, the average savings realised by ESPC projects generally vary between 25% and 40%, recouping the investment in heating, ventilation and air-conditioning (HVAC) retrofits, CHP and biomass implementations within 5 to 15 years. Nevertheless, in many countries the number of projects funded by ESPC still does not form a significant part of the total investment budgeted by public institutions for energy retrofits.

Until now, ESPC has been used primarily as an instrument for HVAC, lighting, and controls. Implementation of some individual measures (for example, building envelope insulation and improved airtightness, or cogeneration) results in significant reductions in building heating and cooling loads or minimization of energy waste, but requires significant investments with long paybacks. However, when different technologies are implemented together,



Residential building renovation achieved 78% energy use reduction in Freiburg (Germany)
Source: KEA

or are 'bundled', they can result in significant energy use reductions, require smaller investments, and consequently have faster paybacks. In this way, this project aims to increase the acceptance of ESPC, and to broaden the implementation of deep energy use reductions through refurbishment of existing buildings using ESPC, or if needed, new business models.

Objectives

The project objectives are to:

- provide a framework, tools and guidelines with the aim of significantly reducing energy use (by more than 50%) and improving indoor environmental quality in government and public buildings and building clusters undergoing renovation,
- research, develop, and demonstrate innovative and highly effective bundled packages of energy conservation measures for selected building types and climatic conditions,
- develop and demonstrate innovative, highly resource-efficient business models for refurbishing buildings and community systems using appropriate combinations of public and private funding, and
- support decision makers in evaluating the efficiency, risks, financial attractiveness, and contractual and tendering options.

Deliverables

The following project deliverables are planned:

- a guide for deep energy retrofits (DERs) of buildings and communities,
- advanced DER business models using combined public and private funding, and
- documented results of realized projects and case studies demonstrating the developed models.

Progress

By the end of 2014, 15 case studies of completed deep energy retrofit projects were documented. For different climatic conditions, the core technology bundles for DER have been identified and characteristics of these technologies established through building modelling. Work on the DER guide is in progress. In November 2014, the project team together with the Building Performance Institute Europe (BPIE) and KEA (Climate protection and energy agency of Baden- Württemberg GmbH) has organized the first 'Investors' Day' to present and discuss interim DER business concepts. Experts from more than 60 financing institutions, building owners, policy makers and high level representatives from the European Commission attended this workshop.

Meetings

- The 2nd project meeting was held in Copenhagen, Denmark in March 2014.
- The 3rd project meeting was held in Tallinn, Estonia in September 2014.

Project duration

2013–2016

Operating Agents

Alexander Zhivov, US Army Engineer Research and Development, USA, and

Rüdiger Lohse, KEA- Climate protection and energy agency of Baden- Württemberg GmbH, Germany

Participating countries

Austria, Australia, Belgium, Canada, Denmark, Finland, Germany, Ireland, Sweden, UK, USA

Observer: Estonia

Further information

www.iea-ebc.org

New Generation Computational Tools for Building and Community Energy Systems

ANNEX 60

To reduce energy use and peak power demand, buildings and district energy systems will need to become increasingly integrated and connected with smart grids. Besides energy-related aspects, occupant health and productivity are also issues of concern. This poses new challenges for building simulation programs to support decision making during product development, building design, commissioning and operation. Therefore, new functional requirements have arisen for computational tools for buildings that are not addressed by existing building simulation programs.

In the meantime, other sectors (such as the automotive and aerospace industries) have been making large

investments in 'next generation' computing tools for complex and dynamic engineering systems. So, the aim of this project is to transfer these developments to the buildings industry. For buildings and community energy systems, it is coordinating the currently fragmented development of next generation computing tools based on two open, non-proprietary standards, the Modelica modelling language and the Functional Mockup Interface standard. The Modelica language allows graphical 'plug and play' modelling of building systems, electrical systems, district heating and cooling networks and controls. The FMI standard and co-simulation middleware allow efficient linking of existing simulation software and the Modelica technology.

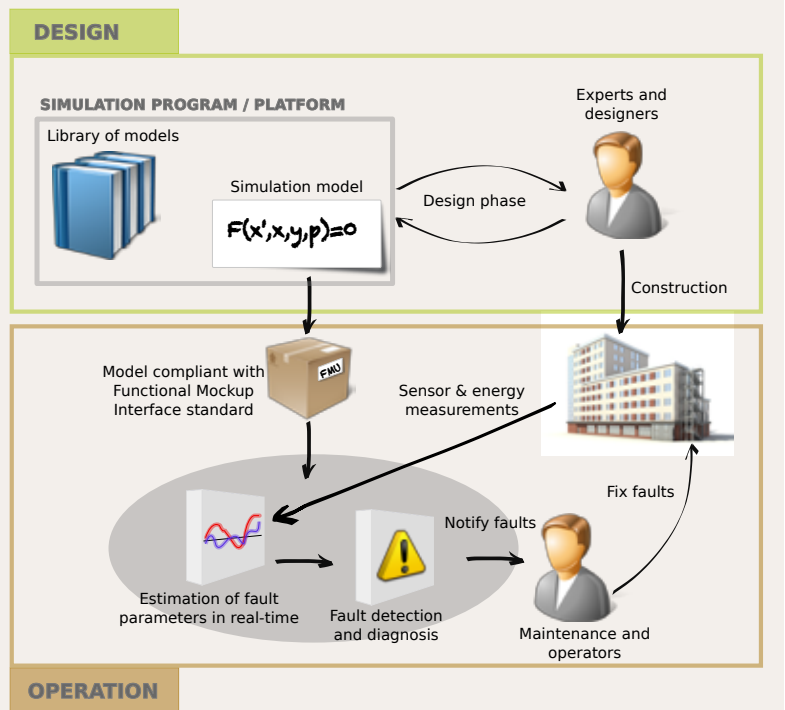
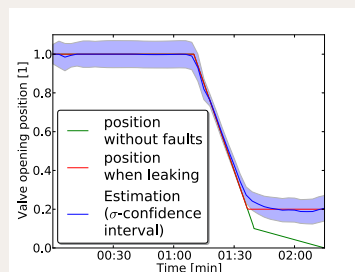
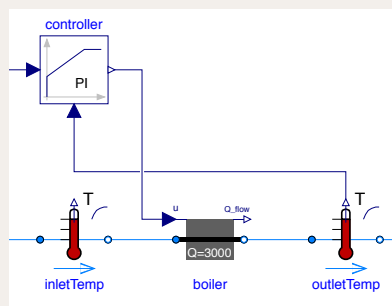

Workflow showing the interoperability of the Modelica and Functional Mockup Interface standards that allow the transformation of a Modelica model from the design phase to a Functional Mockup Unit. The Unit is then used during operation of the building to diagnose and estimate the probability of faults at the component and system levels. It flags performance degradation and its associated energy costs to the operator to ensure persistent high performance.

Source: LBNL

Interfaces to digital building information models (BIM) will allow designers to configure Modelica models from compatible CAD systems. Based on these, the project is further developing and deploying free open source contributions to existing, but previously uncoordinated activities in modelling and simulation of energy systems. As an example, the technology being developed will allow building operators to use models during the operation of buildings for real-time optimization, fault detection and diagnostics to ensure realization and persistence of design intent.

Objectives

The project objectives are to develop, demonstrate and deploy next-generation computational tools that allow buildings and energy grids to be designed and operated as integrated, robust, and performance based systems.

Deliverables

The following project deliverables are planned:

- validated and documented models that can be used within multiple open source and commercial Modelica simulation environments,
- case studies that demonstrate to designers the co-design of building energy and control systems taking into account system dynamics (energy storage and controls), uncertainty and variability, and
- a guidebook that will explain how these technologies can be used in applications that are beyond the capabilities of traditional building simulation programs. Applications include rapid virtual prototyping, design of local and supervisory control algorithms, and deployment of models in support of commissioning and operation.

Progress

In 2014, the following main activities were carried out:

- An open-source free library of Modelica models was developed and integrated as the core of four Modelica libraries for building and community energy systems.

- Import interfaces based on the Functional Mockup Interface standard have been developed that allow importing models of HVAC and control sequences into different simulation programs to extend the capability of these programs. This includes a building automation system allowing reuse of models from the design phase during operation, for example for feedback control, fault detection and diagnostics, or for real-time energy monitoring.
- A new software framework supporting the transformation from BIM to energy performance simulation was developed, making use of a joint data model. A first proof of concept was developed to generate a Modelica systems model from BIM.
- Several case studies have been created that demonstrate the use of Modelica for the design of building and community energy systems.
- Several case studies have been generated that use Modelica and Functional Mockup Units in real time as part of a building management system to support controls, fault detection and diagnostics algorithms.

Meetings

- The 2nd project meeting was held in Lund, Sweden in March 2014.
- The 3rd project meeting was held in Berkeley, CA, USA in September 2014.

Project duration

2012–2017

Operating Agents

Michael Wetter, Lawrence Berkeley National Laboratory, USA, and Christoph van Treeck, RWTH Aachen University, Germany

Participating countries

Austria, Belgium, P.R. China, France, Germany, Ireland, Italy, The Netherlands, Spain, Sweden, Switzerland, USA

Further information

www.iea-ebc.org

High Temperature Cooling and Low Temperature Heating in Buildings

ANNEX 59

It is important to minimise temperature differences in heating, ventilation and air conditioning (HVAC) systems, because high differences result in reduced efficiencies and therefore increased energy use. This project is thus starting from a new perspective and from this is developing a novel concept for analysing HVAC systems in buildings.

The project is focusing on temperature differences throughout HVAC systems, as well as within the indoor spaces that they serve, and on how these can be minimized in highly energy efficient buildings. Temperature differences within HVAC systems can be classified into three types, arising from:

- heat and moisture exchange,
- heat transmission through fluid media, and

- thermal mixing losses in indoor spaces due to different types of indoor terminal devices.

High temperature cooling and low temperature heating would be achieved by reducing temperature differences in heat transfer and energy transportation processes within buildings. The beneficiaries of the outcomes will be designers and industry, including manufacturers of chillers, radiant panels and supply air terminals. The outcomes are also expected to contribute to the development of new HVAC terminal devices.

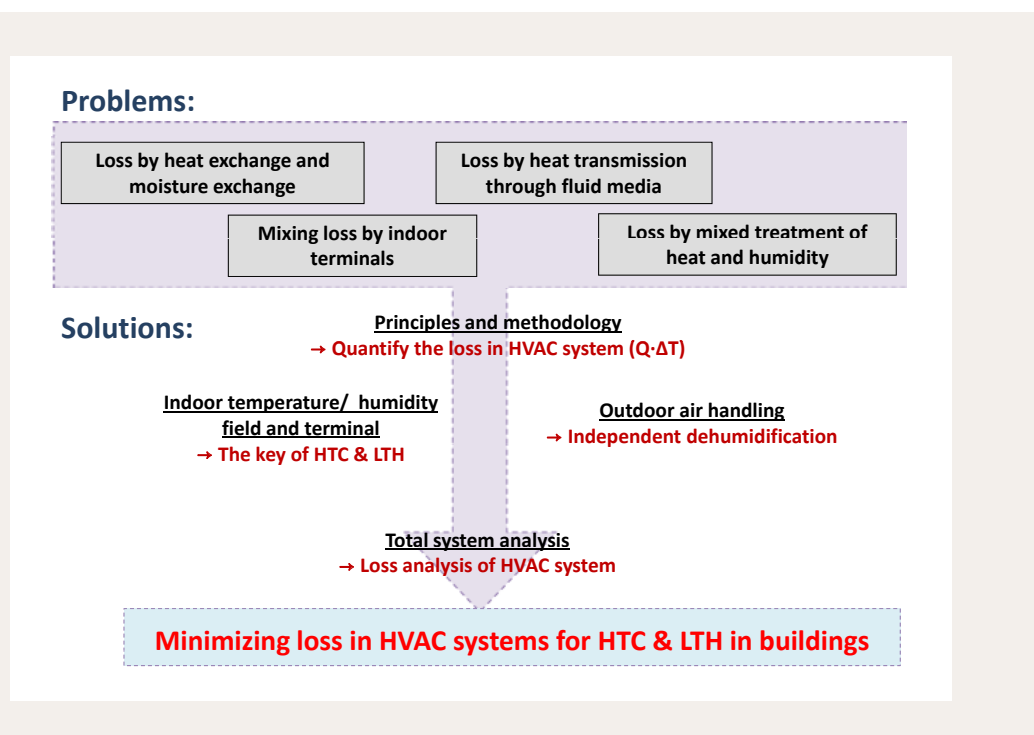

The problems and solutions of high temperature cooling (HTC) and low temperature heating (LTH) in buildings
Source: EBC Annex 59

Objectives

The main project objectives are to:

- establish a methodology for analysing HVAC systems from the perspective of reducing mixing and transfer losses,
- propose novel designs for indoor terminals and novel flow paths for outdoor air handling equipment, and
- develop high temperature cooling and low temperature heating systems in buildings with fully utilized heat and cold sources, high efficiency transportation and appropriate indoor terminals.

Deliverables

The following project deliverables are planned:

- a guide book on a new analysis method for HVAC systems,
- novel designs for indoor terminals in high temperature cooling and low temperature heating systems,
- novel flow paths for outdoor air handling equipment and their application in high temperature cooling and low temperature heating systems,
- a design guide for high temperature cooling and low temperature heating systems with applications, and
- real-time test results for high temperature cooling and low temperature heating systems in typical office buildings under different climatic conditions.

Progress

The following activities took place in 2014:

- An 'ID Chart weight analysis' together with the associated loads were investigated for a reference office building under 10 climates. Analysis of the building using several typical conditions and a normal HVAC system is ongoing.
- A study of dynamic heat transfer processes in radiant floor cooling systems with high solar gains reached the final stage.
- Dehumidification system tests were conducted.
- A first draft of the final project report was completed.

Meetings

- The 5th project meeting was held in Torino, Italy in April 2014.
- The 6th project meeting was held in Nagoya, Japan in October 2014.

Project duration

2012–2015

Operating Agent

Yi Jiang, Tsinghua University, P.R. China

Participating countries

Belgium, P.R. China, Denmark, Finland, Italy, Japan, USA

Further information

www.iea-ebc.org

Reliable Building Energy Performance Characterisation Based on Full Scale Dynamic Measurement

ANNEX 58

To reduce the energy use of buildings and communities, many industrialised countries have imposed stringent requirements for new developments. In most cases, evaluation and labelling of the energy performance of buildings are carried out during the design phase. Several studies have shown, however, that the actual performance after construction may deviate significantly from this theoretically designed performance. As a result, there is growing interest in full scale testing of components and whole buildings to characterise their actual thermal performance and energy efficiency. This full scale testing approach is not only of interest to study building (component) performance under actual conditions, but is also a valuable and necessary tool to deduce simplified models for advanced components and systems to integrate them into building energy simulation models. The same is true to identify suitable models to describe the thermal dynamics of whole buildings including their energy systems, for example when optimising energy grids for building and communities.

It is clear that quantifying the actual performance of buildings, verifying calculation models and integrating new advanced energy solutions for nearly zero or positive energy buildings can only be effectively realised by in situ testing and dynamic data analysis. But, practice shows that the outcome of many on site activities can be questioned in terms of accuracy and reliability. Full scale testing requires a high quality approach during all stages of research, starting with the test environment, such as test cells or real buildings, accuracy of sensors and correct installation, data acquisition software, and so on. It is crucial that the experimental setup (for example the test layout or boundary conditions imposed during testing) is correctly designed, and produces reliable data. These outputs can then be used in dynamic data analysis based on advanced statistical methods to provide accurate characteristics for reliable final application. If the required quality is not achieved at any of the stages, the results become inconclusive or possibly even useless.

This project is therefore developing the necessary knowledge, tools and networks to achieve reliable in situ dynamic testing and data analysis methods that can be used to characterise the actual energy performance of building components and whole buildings. As such, the project is not only of interest for the building community, but is also valuable for policy and decision makers, as it provides opportunities to make the step from (stringent) requirements on paper towards actual energy performance assessment and quality checking.

Objectives

The project objectives are to:

- develop common quality procedures for dynamic full scale testing to realise better performance analysis,
- develop models to characterize and predict the effective thermal performance of building components and whole buildings.

Deliverables

The following project deliverables are planned:

- a report on the state of the art of full scale testing and dynamic data analysis, including a survey of existing full scale test facilities for the benefit of the building industry, engineers and consultants,
- guidelines on how to perform reliable full scale dynamic testing, intended for the building industry and the building research community,
- a description of the methodology to perform dynamic data analysis and performance characterisation, intended for the building research and associated communities,
- a summary report (white paper) on full scale dynamic testing and data analysis to characterise building energy performance, intended for the building research and associated communities,
- a few, well-documented dynamic data sets that can be used for developing dynamic data analysis procedures and for validation purposes, aimed at software developers and the building research community, and

- a synthesis report, demonstrating the applications of the developed framework, intended for building designers and industry, government and other authorities.

Progress

The following activities took place in 2014:

- A first draft of the state of the art report was created.
- In situ characterisation under real climatic conditions was performed on a test box (a scale model of a building) in Belgium and Spain and on a test house (see picture below) in Germany.
- A decision tree to guide and optimise full scale testing was further developed.
- Common exercises were run on dynamic data analysis and on the validation of common building energy simulation models.

Meetings

In 2014, two experts meetings took place in:

- Gent, Belgium, in April 2014, and
- Berkeley, USA, in September 2014.

Project duration

2011–2015

Operating Agent

Staf Roels, University of Leuven, Belgium

Participating countries

Austria, Belgium, P.R. China, Czech Republic, Denmark, Finland, France, Germany, Italy, The Netherlands, Norway, Spain, UK, USA

Further information

www.iea-ebc.org



On site building fabric performance assessment by a co-heating test. By measuring the heat input necessary to heat the dwelling to an elevated steady-state temperature, the overall actual heat loss coefficient can be determined and compared with the design value.

Source: EBC Annex 58

Evaluation of Embodied Energy and Carbon Dioxide Equivalent Emissions for Building Construction

ANNEX 57

Embodied energy consumption (EE) and carbon dioxide emissions (EC) associated with building construction and civil engineering account for about 20% of the entire global energy consumption and CO₂ emissions. The proportions are approximately 5% to 10% of the entire energy consumption in developed countries and 10% to 35% in developing countries. Though the levels vary greatly depending on the country and region, decreases in EE-EC have a significant effect on overall reductions.

A hurdle to reducing EE-EC in construction is that a variety of methodologies supported by materials databases already exist, but these have been based on differing definitions. For instance, certain methodologies take account of non-CO₂ greenhouse gases and quantify them as 'embodied carbon equivalents' (EC_{eq}). The purpose of the current project is therefore to develop guidelines for:

Long-life office building with an atrium (Denmark)		
	Standard	Resilient
Reference period (years)	50	100
EC (kg-CO ₂ /m ² year)	7.9	4.8



This office building was constructed using concrete, steel and aluminum accounting respectively for 42%, 37% and 8% of EC. A reduction was achieved by increasing service life, with the annual EC reduced by approximately 40%. Source: Henning Larsen Architects

Comparison of wooden lightweight timber frame and reinforce concrete (RC) buildings (Korea)		
	Wooden	RC
Reference period (years)	50	50
EC (kg-CO ₂ /m ² year)	8.3	16.8



The EC for a wooden lightweight timber frame dwelling was compared with 60 units located in a reinforced concrete multi-family block. The floor area of was 165 m² for the dwelling and 80 m² for each unit. The results show that wooden construction contributes to an EC reduction of approximately 50%. Source: Korea Institute of Civil Engineering and Building Technology (KICT)

Comparison of using new and reused materials (Czech Republic)		
	New	Reuse
Reference period (years)	60	60
EC (kg-CO ₂ /m ² year)	6.4	6.1



Reduced EC due to the reuse of building materials was relatively low, the effect of which is only about 5%. The impact was not as much as expected since steel and concrete are already reused by industry. Most of the reused material was bricks. Source: Czech Technical University in Prague

The case studies analysed in the project

- reliable and comparable methods for evaluating EE-EC due to building construction, and
- measures to design and construct buildings with reduced EE-EC.

The project is also analysing various methods for reducing EE-EC in a quantitative manner through case studies. The analysis of the case studies includes explaining the methods applied to reduce EC and their impacts.

Objectives

The project objectives are to:

- collect existing research results concerning EE-EC to summarize them into a state of the art report,
- develop methods for evaluating EE and EC_{eq} resulting from building construction, and
- develop measures to design and construct buildings with reduced EE and EC_{eq}.

Deliverables

The following project deliverables are planned:

- a final project report including case studies from individual countries,
- guidelines for building designers, policy makers, construction product manufacturers, procurement, education institutions, and
- a project summary report outlining the technical outputs from the project.

Progress

The following activities took place in 2014:

- A draft of the guidelines for designers was completed.
- Databases and standards regarding primary energy in various countries were collated.
- EC_{eq} in individual countries between 1995 and 2009 were estimated to obtain the fraction of total CO₂ emissions.
- Methods for achieving long-life construction and their effects in terms of existing buildings were analysed to estimate the reduction effect on EE- EC_{eq}.

- The impacts on global warming of freon contained in insulating materials and air conditioning equipment for existing buildings were assessed.
- Case studies from various countries were collated. The case studies quantified a reduction of EE-EC_{eq} in various types of buildings such as zero energy buildings, long-life construction buildings, wooden construction buildings using recycled materials, and so on.

Meetings

- The 6th expert meeting took place in Trondheim, Norway in April 2014.
- The 7th expert meeting took place in Barcelona, Spain in October 2014.

Project duration

2011–2016

Operating Agent

Tatsuo Oka, Utsunomiya University, Japan

Participating countries

Australia, Austria, China, Czech Republic, Denmark, Finland, Germany, Japan, Republic of Korea, The Netherlands, Norway, Poland, Portugal, Sweden, Switzerland, UK

Observer: Brazil

Further information

www.iea-ebc.org

Cost Effective Energy and Carbon Dioxide Emissions Optimization in Building Renovation

ANNEX 56

In recent years, various standards and regulations for energy consumption in buildings have emerged that specify greatly improved levels of energy efficiency in comparison with earlier requirements. However, these mainly focus on new buildings and they do not respond effectively to the numerous technical, functional and economic constraints of the existing stock. It is common that requirements for existing buildings, which are generally targeted at energy efficiency measures, result in expensive processes and complex procedures, seldom accepted by occupants, owners or developers. These procedures can be simplified if onsite generation of renewable energy is considered during the renovation process, potentially reducing the amount of work needed for energy efficiency measures.



Pilot project Backa röd, Sweden – View of the building before renovation (top) and after renovation (bottom).
Source: Lund University

Within the overall objective of slowing down climate change by reducing carbon dioxide (CO₂) emissions, renewable energy supply measures are as effective as energy conservation and efficiency measures. They might be even more cost effective, particularly when the goal is achieving both nearly-zero emissions and energy buildings. Therefore, the most cost effective renovation solution in existing buildings is often a combination of energy efficiency measures and measures that promote the use of renewable energy or renewable energy produced on-site. So, it is important to investigate where the balance point lies between these two types of measures from a cost-benefit perspective.

This involves determining how the best performance (in terms of less energy use, reduced CO₂ emissions and other benefits) would be achieved with the least effort (in terms of financial investment, depth and duration of interventions and disturbance of occupants). Therefore, a new methodology for energy and CO₂ emissions optimized building renovation has been developed to be used by interested private entities helping them in their renovation decisions, as well as by governmental agencies for the development of regulations and their implementation.

Objectives

The project objectives are to:

- define a methodology for establishing cost optimized targets for energy consumption and CO₂ emissions in building renovation,
- clarify the relationship between CO₂ emissions and energy targets and their eventual hierarchy,
- determine cost effective combinations of energy efficiency and renewable energy supply measures,
- highlight the relevance of additional benefits achieved in the renovation process,
- develop or adapt tools to support decision makers in accordance with the developed methodology, and

- select exemplary case studies to encourage decision makers to promote efficient and cost effective renovations.

Deliverables

Supported by a dedicated website and bi-annual newsletters, the following deliverables are planned:

- 'Methodology for Cost Effective Energy and Carbon Emissions Optimization in Building Renovation' report,
- 'Parametric Calculations for the Assessment of the Impacts of Energy Related Building Renovation Measures' report,
- 'Integration of LCIA into the Assessment of Renovation Measures' report,
- 'Co-Benefits of Building Renovation: Integration into Assessment and Promotion of Renovation Measures' report,
- Decision making tools,
- 'Shining Examples' brochure,
- 'Detailed Case Studies' report,
- 'Literature Review on User Acceptance', and
- 'Renovation Guidebook', including a summary for policy makers.

Progress

During 2014, the first edition of the 'Shining Examples' brochure on building renovation was published. This presents a selection of successful demonstration projects realised in various countries to motivate and inspire a general, non-technical audience. Further demonstration examples are being collected and will be published in an updated edition of the brochure.

Also in 2014, an initial report to explain the project methodology and parametric calculations for generic buildings was published. This includes information for policy makers and has been sent to the European Commission to inform the preparation process for the national renovation plans being made by the EU

Member States. By the end of the year, the final version of the report, 'Methodology for Cost Effective Energy and Carbon Emissions Optimization in Building Renovation' was completed, reviewed and ready for publication.

Besides the above, the following activities were carried out in 2014:

- Further generic calculations were performed for multi-family buildings to analyse the integration of ventilation as an energy-related renovation measure, the impacts of cooling, the integration of embodied energy use and for sensitivity analysis.
- Interviews were carried out with the users of the renovated building from the case studies to identify and quantify the co-benefits associated with renovation process, which will lead to a report on user acceptance issues.
- Assessments were made of the renovation scenarios defined in the detailed case studies, by calculating life cycle impacts and life cycle costs for each scenario.
- Guidelines were prepared for policy makers and building owners.

Meetings

- The 6th project meeting took place in Alicante, Spain in March 2014.
- The 7th project meeting took place in Brno, Czech Republic in September 2014.

.....
Project duration
 2010–2015

.....
Operating Agent
 Manuela Almeida, University of Minho, Portugal

.....
Participating countries
 Austria, P.R.China, Czech Republic, Denmark, Finland, Italy, The Netherlands, Norway, Portugal, Spain, Switzerland, Sweden

.....
Further information
www.iea-ebc.org

Reliability of Energy Efficient Building Retrofitting – Probability Assessment of Performance and Cost

ANNEX 55

Nowadays, building energy use and durability issues are some of the most important topics in industrialised countries. Even though considerable progress has been achieved concerning new buildings (low energy, passive houses, zero energy) and advanced building services, the buildings sector still generally accounts for the largest share of energy-related carbon dioxide (CO₂) emissions.

While in many industrialised countries, new buildings are constructed every year corresponding to approximately 1% of the existing building stock, commonly more than 50% of the building stock dates from before the first energy crisis in the 1970s. Hence, a large potential for energy savings and consequently CO₂ emissions reduction is presently available in the existing building stock.

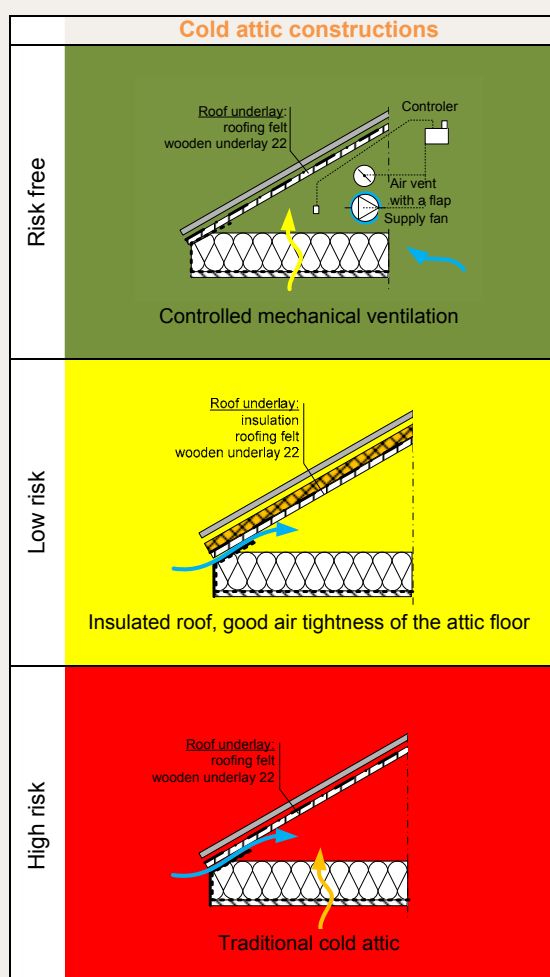

An example of the risk levels for various roof constructions.
Source: EBC Annex 55

Retrofit measures are therefore of the utmost importance for upgrading the building stock. But, many building owners are only interested in the initial capital cost. Looking at the risks associated with the actual performance of such measures and the costs incurred highlights the need for life cycle thinking. So, applicable calculation methods are required in this area. For this purpose, probability assessment in life cycle costing of solutions supports sound decision making relating to investments. For industry, customer relationships are based on future expectations and confidence. These need to be supported by proper probability assessments.

The project is improving methods and tools for integrated evaluation and optimization of retrofitting measures, including energy efficiency, life cycle cost and durability. It will demonstrate to decision makers, designers and practitioners the benefits of the renewal of the existing building stock and how to create reliable solutions.

Objectives

The objectives are to provide decision support data and to develop tools for energy retrofitting measures, focussing on residential building envelopes. These tools are being based on probabilistic methodologies. Specifically, the project will:

- develop and validate probabilistic methods and tools for prediction of energy use, lifecycle cost and functional performance,
- apply and demonstrate probabilistic methodologies on real life case studies, and
- create guidelines for practitioners, including assessment of common retrofitting techniques.

Deliverables

The deliverables from the project are:

- a methodology for probability based assessment of energy retrofitting measures,
- analyses of case studies to show how to apply probability assessment to enhance energy savings, secure performance and apply cost analyses, and
- a report and electronic database for stochastic inputs, validation data, and guidelines for practitioners.

Progress

During 2014, the following were being finalised:

- 'Stochastic Input' and 'Stochastic Validation' datasets
- 'Probability Based Assessment of Energy Retrofitting Measures - Part I: Calculation Tools' report
- 'Probability based Assessment of Energy Retrofitting Measures - Part II: Framework / Assessment schemes and Case Studies' report
- 'Guidelines for Practitioners. Part I: Listing of Frequently Used Retrofitting Technologies - Benefits and Risks' report
- Guidelines for Practitioners. Part II: Guidelines for How to Use the Developed Framework for Practitioners' report

Meetings

The closing meeting took place in Lund, Sweden, in June 2014.

Project duration

2010–2014

Operating Agent

Carl-Eric Hagentoft, Chalmers University of Technology, Sweden

Participating countries

Austria, Belgium, Canada, Denmark, Finland, Germany, The Netherlands, Portugal, Sweden, UK, USA
Observers: Brazil, Slovakia, Estonia

Further information

www.iea-ebc.org

Air Infiltration and Ventilation Centre

ANNEX 5

The primary objective of the EBC information centre, 'Air Infiltration and Ventilation Centre' (AIVC), is to be the leading international information centre on research and development in the fields of air infiltration and ventilation. Thus, the specific objective is to provide a high quality international technical and information forum covering the areas of ventilation and air infiltration in the built environment with respect to efficient energy use, good indoor air quality and thermal comfort. The mission of the AIVC is to be the reference portal for information on ventilation in buildings to improve the wellbeing of people

through development and dissemination of ventilation knowledge.

A key ambition of the AIVC is to convene integrated and combined activities (called 'projects'), resulting in different information tools, for example webinars, workshops, position papers, technical papers, and so on. These are supported by a review process and result in an increased information dissemination impact. The projects initiated since 2011 are:

- Residential cooker hoods in low energy buildings
- Durability of building airtightness
- Quality of methods for measuring ventilation and infiltration in buildings
- Competent tester schemes for building airtightness testing
- Ventilation and health
- Improving the quality of residential ventilation systems
- Ventilative cooling, which is the use of natural or mechanical ventilation strategies to cool indoor spaces - this has resulted in the launch of EBC Annex 62
- Testing, reporting and quality schemes for building airtightness
- Philosophy for setting building airtightness requirements
- Development and applications of building air leakage databases



AIVC Newsletters

For the current focus, with projects and events in relation to airtightness and ventilative cooling, AIVC is joining forces with two other information platforms, i.e. TightVent and venticool. TightVent is focusing on airtightness of buildings and ductwork and was launched in January 2011. Venticool is focusing on ventilative cooling and was launched in September 2012. The main goals of TightVent and venticool are to:

- raise awareness of airtightness and ventilative cooling issues respectively, which are relevant concerns for a wide range of buildings and may even be critical in nearly zero energy buildings, and
- provide appropriate support tools and knowledge transfer to ease market transformation.

In 2014, the 35th AIVC Annual Conference was held in Poznan, Poland. This has once again provided an opportunity for over 140 researchers and practitioners from around the world to exchange ideas and to present their latest findings.

NEW PRODUCTS

Website

In October 2013, the AIVC launched its new website, which is now database driven with 'Web 2.0' functionalities. This includes a powerful search engine for the bibliographic database AIRBASE containing over 21 000 references and 10 000 PDF documents.

Edited proceedings

'Securing the quality of ventilation systems in residential buildings: existing approaches in various countries'

AIVC Conference Proceedings

35th Annual Conference, 'Ventilation and airtightness in transforming the building stock to high performance', held 24th - 25th September 2014, Poznan, Poland

AIVC Newsletter

January 2014

September 2014

WEBINARS

- Airtightness testing part 3: status and trends in competent tester schemes in Denmark, Ireland and Sweden, held in November 2014

Project duration

1979-present

Operating Agent

Peter Wouters, INIVE eeig, Belgium

Participating countries

Belgium, Czech Republic, Denmark, France, Germany, Greece, Italy, Japan, Republic of Korea, The Netherlands, New Zealand, Norway, Portugal, Sweden, USA

Further information and reports

www.iea-ebc.org

www.aivc.org



Completed Research Projects

—————
**INTEGRATION OF MICRO-GENERATION AND RELATED
ENERGY TECHNOLOGIES IN BUILDINGS (ANNEX 54)**

—————
TOWARDS NET ZERO ENERGY SOLAR BUILDINGS (ANNEX 52)

Integration of Micro-Generation and Related Energy Technologies in Buildings

ANNEX 54

Microgeneration consists of technologies for providing energy for single buildings. Typically, small scale systems of up to around 10 kilowatts are used. The combined production of heat and power (CHP) in a single small scale process is called micro-cogeneration (μ CHP). This can be extended to a micro-trigeneration system, if cooling power is also produced. Microgeneration also consists of technologies for small scale electricity generation, such as photovoltaic or micro-wind turbines.

Activities within this project completed in 2014 have focussed on complete building integrated systems, also including thermal and electrical energy storage, chillers, balance of plant components, such as pumps and heat exchangers, and advanced control strategies. The effects of microgeneration on power distribution systems have

been analysed looking specifically at the building level for single and multiple residences, along with small commercial premises.

Achievements

Significant advances regarding the following research topics have been accomplished within the project:

- Field tests and laboratory measurements of microgeneration systems have been conducted to derive performance parameters and input data for simulation models.
- Technical models for different microgeneration technologies have been developed, such as cogenerators with combustion engines, fuel cells or Stirling engines, photovoltaic systems, thermal and electrical storage and balance of plant components.

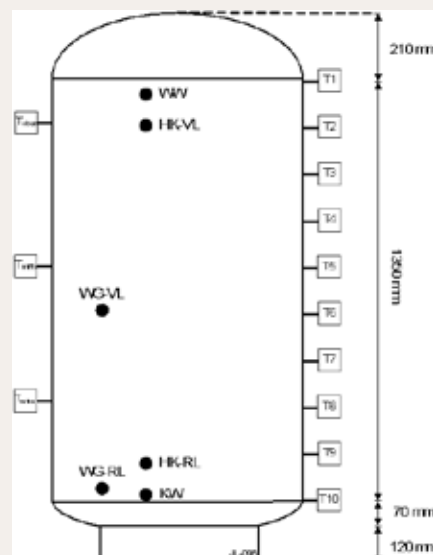

A thermal storage system used in the tests.
Source: TUM

These models have been validated using data from laboratory and field measurements.

- Simulations have been used to create an extensive library of performance assessment studies covering different combinations of technology types, performance in different countries and with different end users. The simulation work initially concentrated on improving and optimising the performance of basic, but realistic microgeneration systems. Subsequent work featured a wider range of system components, system functions and end users.
- Dissemination strategies for the mass deployment of microgeneration related technologies have been investigated. This activity was informed by a regulatory and market review, along with data emerging from technical analyses and performance assessment studies.

A number of key outcomes have emerged from the work carried out, including the following:

- Component and system models have been developed and implemented in building simulation tools, including TRNSYS and ESPr.
- Performance assessment studies of microgeneration systems have shown that energy-related CO₂ emissions reductions in the range of 5% to 20% can be reached using cogeneration systems and up to 40% if renewable energy resources are integrated additionally.
- Storage systems, thermal storage in particular, are important components to increase system performance and to decouple the supply from the demand side.
- Most applications are not yet economically viable without support, such as investment grants or feed-in tariffs. However, some niche applications are now already economically viable without subsidies.

Publications

The following publications have been produced by the project:

- An International Survey of Electrical and DHW Load Profiles for Use in Simulating the Performance of Residential Micro-cogeneration Systems,
- Current Updates on the Development and Implementation of Micro-Cogeneration System Models for Building Simulation Programs,
- Methodologies for the Performance Assessment of Micro Hybrid Polygeneration Systems,
- Report on Microgen Impacts on the Wider Community
- A Comparative Review of Microgeneration Policy Instruments in OECD Countries,
- Synthesis on Microgeneration Performance Assessment, and
- Final Report.

All reports are available for free download from the EBC website (see below).

Project duration

2009–2014

Operating Agents

Evgueniy Entchev, Natural Resources Canada, Canada, and Peter Tzscheutschler, Technische Universität München (TUM), Germany

Participating countries

Belgium, Canada, Denmark, Germany, Italy, Japan, Republic of Korea, The Netherlands, UK, USA

Further information

www.iea-ebc.org

Towards Net Zero Energy Solar Buildings

ANNEX 52

A number of International Energy Agency (IEA) member countries have adopted a vision of so-called 'net zero energy buildings' (NZEBs) as long-term goals of their energy policies. However, what was previously missing was a clear definition and international agreement on the measures of building performance that could inform 'zero energy' building policies, programmes and industry adoption worldwide. These have been achieved in this project, which has been run jointly with the IEA research programme on Solar Heating and Cooling.

Although there are no standard approaches for designing and realizing NZEBs, there are many different possible combinations of building envelope, services equipment and on-site energy production equipment capable of collectively achieving net-zero energy performance. There is now, however, a general consensus that zero energy building design should start from the approach of passive sustainable design. Such an approach plays a crucial role in addressing NZEB design by reducing the necessary active heating, cooling, ventilation and lighting loads put on the building's mechanical and electrical systems, and indirectly, the requirement for renewable energy generation. According to the specific NZEB definition, this level of performance can be achieved through the combination of two fundamental steps:

- reduce building energy demand (achieved through passive sustainable design), and
- generate sufficient electricity or other energy from renewable sources to attain the desired energy balance.

Achievements

This project, which was successfully completed in 2014, has studied current net zero, near net zero and very low energy buildings. It has developed a common understanding, a harmonized international definitions framework, tools, innovative solutions and industry guidelines. This was achieved primarily by documenting

and proposing practical net zero energy building (NZEB) demonstration projects, with convincing architectural quality. These exemplars, supported by a sourcebook, guidelines and tools, are considered to be essential for industry adoption. The achieved project objectives were to:

- establish an internationally agreed understanding of NZEBs, based on a common methodology,
- identify and refine design approaches and tools to support industry adoption,
- develop and test innovative, whole building net zero solution sets for cold, moderate and hot climates with exemplary architecture and technologies that would be



One of thirty project case studies - Kraftwerk B in Switzerland (top) is a well insulated building that extensively uses renewable technologies, in particular photovoltaic panels and thermal solar collectors integrated into the facade. The EnergyPlus model (bottom) assisted in the analysis of the performance of the building.

Source: EBC Annex 52

- the basis for demonstration projects and international collaboration, and
- support knowledge transfer and market adoption of NZEBs at a national and international level.

The project has investigated the cost effective equalisation of the small annual energy needs of such buildings through building integrated heating and cooling systems, power generation and interactions with utilities. It has learnt from recent industry experiences with net zero and low energy solar buildings and the most recent developments in whole building integrated design and operation. This joint international research and demonstration activity has addressed concerns of comparability of performance calculations between building types and communities for different climates. Further, it has produced solution sets intended for broad industry adoption.

The scope has included major building types (residential and non-residential), new and existing buildings in various climatic zones represented by the participating countries. The work has linked to national activities and has focused on individual buildings, clusters of buildings and neighbourhoods. It has been based on analysis of existing examples, leading to the development of innovative solutions to be incorporated into national demonstration buildings.

Publications

The following official publications arising from the project target specific groups including national policy makers, national funding programs, industry, and academia:

- Source Book Volume 1: Net Zero Energy Buildings: International Projects of Carbon Neutrality in Buildings
- Source Book Volume 2: Modelling, Design, and Optimization Net Zero Energy Buildings
- Source Book Volume 3: Solution Sets for Net Zero

Energy Buildings - Feedback from 30 Net-ZEBs worldwide

- Life Cycle Analysis report
- Analysis of Load Match and Grid Interaction Indicators in NetZEBs with High Resolution Data report
- Measurement and Verification Protocol of NetZEBs report

The three Source Book Volumes are available from the publishers, while the other reports can be freely downloaded from the EBC website (see below).

Project duration

2008 – 2014

Operating Agent

Josef Ayoub, CanmetENERGY, Natural Resources Canada, Canada

Participating countries

Australia, Austria, Belgium, Canada, Denmark, Finland, France, Germany, Italy, Republic of Korea, New Zealand, Norway, Portugal, Singapore, Spain, Sweden, Switzerland, UK, USA

Further information

www.iea-ebc.org

www.iea-shc.org

Background Information

—————
EBC AND THE IEA

—————
RECENT PUBLICATIONS

—————
EBC EXECUTIVE COMMITTEE MEMBERS

—————
EBC OPERATING AGENTS

—————
PAST PROJECTS

EBC and the IEA

THE INTERNATIONAL ENERGY AGENCY

The International Energy Agency (IEA) was established in 1974 within the framework of the Organisation for Economic Cooperation and Development (OECD) to implement an international energy programme. A basic aim of the IEA is to foster cooperation among the twenty eight IEA member countries and to increase energy security through energy conservation, development of alternative energy sources and energy research, development and demonstration (RD&D). The current framework for international energy technology RD&D cooperation was approved by the IEA's Governing Board in 2003. More information about the energy technology RD&D framework can be found at: www.iea.org/techinitiatives.

This framework provides uncomplicated, common rules for participation in research programmes, known as 'Implementing Agreements', and simplifies international cooperation between national entities, business and industry. Implementing Agreements are legal agreements between countries that wish to pursue a common programme of research in a particular area. In fact, there are now over 40 such programmes. There are numerous advantages to international energy technology RD&D collaboration through the IEA Implementing Agreements, including:

- Reduced cost and avoiding duplication of work
- Greater project scale
- Information sharing and networking
- Linking IEA member countries and non-member countries
- Linking research, industry and policy
- Accelerated development and deployment
- Harmonised technical standards
- Strengthened national RD&D capabilities
- Intellectual property rights protection

ABOUT EBC

Approximately one third of primary energy is consumed in non-industrial buildings such as dwellings, offices, hospitals, and schools where it is utilised for the heating and cooling, lighting and operation of appliances. In terms of the total energy end-use, this consumption is comparable to that used in the entire transport sector. Hence the building sector represents a major contribution to fossil fuel use and related carbon dioxide emissions. Following uncertainties in energy supply and concern over the risk of global warming, many countries have now introduced target values for reduced energy use in buildings. Overall, these are aimed at reducing energy consumption by between 5% and 30%. To achieve such a target, international cooperation, in which research activities and knowledge can be shared, is seen as an essential activity.

In recognition of the significance of energy use in buildings, in 1977 the International Energy Agency has established an Implementing Agreement on Energy in Buildings and Communities (EBC-formerly known as ECBCS). The function of EBC is to undertake research and provide an international focus for building energy efficiency. Tasks are undertaken through a series of 'Annexes', so called because they are legally established as annexes to the EBC Implementing Agreement. These Annexes are directed at energy saving technologies and activities that support technology application in practice. Results are also used in the formulation of international and national energy conservation policies and standards.

OBJECTIVES AND STRATEGY

The objectives of the collaborative work conducted by the EBC Implementing Agreement are derived from the major trends in construction and energy markets, energy research policies in the participating countries and from the general objectives of the IEA. The principal objective of the EBC is to facilitate and accelerate the introduction of new and improved energy conservation and environmentally sustainable technologies into buildings and community systems. Specific objectives of the EBC programme are to:

- support the development of generic energy conservation technologies within international collaboration;
- support technology transfer to industry and to other end users by the dissemination of information through demonstration projects and case studies;
- contribute to the development of design methods, test methods, measuring techniques, and evaluation/assessment methods encouraging their use for standardisation;
- ensure acceptable indoor air quality through energy efficient ventilation techniques and strategies;
- develop the basic knowledge of the interactions between buildings and the environment as well as the development of design and analysis methodologies to account for such interactions.

The research and development activities cover both new and existing buildings, and residential, public and commercial buildings. The main research drivers for the programme are:

- the environmental impacts of fossil fuels;
- business processes to meet energy and environmental targets;
- building technologies to reduce energy consumption;
- reduction of greenhouse gas emissions;
- the 'whole building' performance approach;
- sustainability;
- the impact of energy reduction measures

- on indoor health, comfort and usability;
- the exploitation of innovation and information technology;
- integrating changes in lifestyle, work and business environments.

MISSION STATEMENT

The mission of the IEA Energy in Buildings and Communities Programme is as follows: 'To accelerate the transformation of the built environment towards more energy efficient and sustainable buildings and communities, by the development and dissemination of knowledge and technologies through international collaborative research and innovation.'

NATURE OF EBC ACTIVITIES

- Formal coordination through shared tasks: This represents the primary approach of developing the work of EBC. The majority of Annexes are task-shared and involve a responsibility from each country to commit manpower.
- Formal coordination through cost shared activities: EBC currently supports one cost shared project, Annex 5, the Air Infiltration and Ventilation Centre (AIVC). In recent times, Annex 5 has subcontracted its information dissemination activities to the Operating Agent, by means of a partial subsidy of costs and the right to exploit the Annex's past products.
- Informal coordination or initiation of activities by participants: Many organizations and groups take part in the activities of EBC including government bodies, universities, nonprofit making research institutes and industry.
- Information exchange: Information about associated activities is exchanged through the EBC and through individual projects.

The EBC website (www.iea-ebc.org), for example, provides links to associated research organizations. Participants in each project are frequently associated with non IEA activities and can thus ensure a good cross-fertilization of knowledge about independent activities. Information exchange additionally takes place through regular technical presentation sessions and 'Future Buildings Forum' workshops. Information on independent activities is also exchanged through the EBC newsletter, which, for example, carries regular reports of energy policy development and research activities taking place in various countries.

EBC PARTICIPATING COUNTRIES

Australia
Austria
Belgium
Canada
P.R. China
Czech Republic
Denmark
Finland
France
Germany
Greece
Italy
Ireland
Japan
Republic of Korea
New Zealand
The Netherlands
Norway
Poland
Portugal
Spain
Sweden
Switzerland
Turkey
United Kingdom
United States of America

COORDINATION WITH OTHER BODIES

In order to achieve high efficiency in the R&D programme and to eliminate duplication of work it is important to collaborate with other IEA buildings-related Implementing Agreements. The coordination of strategic plans is a starting point to identify common R&D topics. Other actions are exchange of information, joint meetings and joint projects in areas of common interest. It is a duty of the Chairs of the respective Executive Committees to keep the others informed about their activities and to seek areas of common interest.

COLLABORATION WITH IEA BUILDING-RELATED IMPLEMENTING AGREEMENTS

The EBC Programme continues to coordinate its research activities, including Annexes and strategic planning, with all IEA Building-Related Implementing Agreements through collaborative projects and through the BCG (Buildings Coordination Group), constituted by the IEA Energy End Use Working Party (EUWP) Vice Chair for Buildings and the Executive Committee Chairs of the following IEA research programmes:

- District Heating And Cooling (DHC)
- Demand Side Management (DSM)
- Energy in Buildings and Communities (EBC)
- Energy Conservation through Energy Storage (ECES)
- Heat Pumping Technologies (HPT)
- Photovoltaic Power Systems (PVPS)
- Solar Heating and Cooling (SHC)
- Energy Efficient Electrical Equipment (4E)

Beyond the BCG meetings, EBC meets with representatives of all building-related IA's at Future Buildings Forum (FBF) Think Tanks and Workshops. The outcome from each Future Buildings Forum Think Tank is used strategically by the various IEA buildings related Implementing Agreements to help in the development of their work programmes over the subsequent five year period.

Proposals for new research projects are discussed in coordination with these other programmes to pool expertise and to avoid duplication of research. Coordination with SHC is particularly strong.

COLLABORATION WITH THE IEA SOLAR HEATING AND COOLING PROGRAMME

While there are several IEA programmes that are related to the buildings sector, the EBC and the Solar Heating and Cooling programmes focus primarily on buildings and communities. Synergies between these two programmes occur because one programme seeks to cost-effectively reduce energy demand while the other seeks to meet a large portion of this demand by solar energy. The combined effect results in buildings that require less purchased energy, thereby saving money and conventional energy resources, and reducing CO₂ emissions. The areas of responsibility of the two programmes have been reviewed and agreed. EBC has primary responsibility for efficient use of energy in buildings and community systems. Solar designs and solar technologies to supply energy to buildings remain the primary responsibility of the SHC Programme.

The Executive Committees coordinate the work done by the two programmes. These Executive Committees meet together approximately every two years. At these meetings matters of common interest are discussed, including planned new tasks, programme effectiveness and opportunities for greater success via coordination. The programmes agreed to a formal procedure for coordination of their work activities. Under this agreement during the initial planning for each new Annex/Task initiated by either programme, the other Executive Committee is invited to determine the degree of coordination, if any. This coordination may range from information exchange, inputting to the draft Annex/Task Work Plan, participating in Annex/Task meetings to joint research collaboration.

The mission statements of the two programmes are compatible in that both seek to reduce the purchased energy for buildings; one by making buildings more energy efficient and the other by using solar designs and technologies. Specifically, the missions of the two programmes are:

- EBC programme – to accelerate the transformation of the built environment towards more energy efficient and sustainable buildings and communities, by the development and dissemination of knowledge and technologies through international collaborative research and innovation.
- SHC programme – to enhance collective knowledge and application of solar heating and cooling through international collaboration in order to fulfill the vision.

The two programmes structure their work around a series of objectives. Four objectives are essentially the same for both programmes. These are:

- technology development via international collaboration;
- information dissemination to target audiences;
- enhancing building standards;
- interaction with developing countries.

The other objectives differ. The EBC programme addresses life cycle environmental accounting of buildings and their constituent materials and components, as well as indoor air quality, while the SHC Programme addresses market impacts, and environmental benefits of solar designs and technologies. Both Executive Committees understand that they are addressing complementary aspects of the buildings sector and are committed to continue their coordinated approach to reducing the use of purchased energy in buildings sector markets.

NON-IEA ACTIVITIES

A further way in which ideas are progressed and duplication is avoided is through cooperation with other building related activities. Formal and informal links are maintained with other international bodies, including:

- The International Council for Research and Innovation in Building and Construction (CIB),
- The European Commission (EC) including the BUILD UP initiative,
- The International Standards Organization (ISO), and-
- The American Society of Heating, Refrigeration and Air Conditioning Engineers (ASHRAE).

Recent Publications

Air Infiltration and Ventilation Centre (AIVC) – Annex 5

Database

AIRBASE – bibliographical database, containing over 21,000 records on air infiltration, ventilation and related areas, Web based, updated every 3 months

Technical Notes

- TN 67 Building airtightness: a critical review of testing, reporting and quality schemes in 10 countries, 2012
- TN 66 Building air leakage databases in energy conservation policies: analysis of selected initiatives in 4 European countries and the USA, 2012

AIVC Conference Proceedings

2014 Poland - Ventilation and airtightness in transforming the building stock to high performance

Energy Efficient Communities: Case Studies and Strategic Guidance for Urban Decision Makers – Annex 51

- Case Studies and Guidelines for Energy Efficient Communities, A Guidebook on Successful Urban Energy Planning, Publisher: Fraunhofer IRB Verlag, Stuttgart 2013
- District Energy Concept Adviser, March 2013
- Project Summary Report, Reinhard Jank, October 2014

Towards Net Zero Energy Solar Buildings – Annex 52

- Evaluation tool for net zero energy buildings: application on office building, March 2013
- Source Book Volume 1: Net Zero Energy Buildings: International Projects of Carbon Neutrality in Buildings, Karsten Voss and Eike Musall, Detail, Germany, 2012
- LCE analysis of buildings - Taking the step towards Net Zero Energy Buildings,

Annamaria Belleri, Assunta Napolitano, May 2013

- Analysis Of Load Match and Grid Interaction Indicators in NZEB with High-Resolution Data, Jaume Salom, Anna Joanna Marszal, José Candanedo, Joakim Widén, Karen Byskov Lindberg, Igor Sartori, March 2014
- Measurement and Verification protocol for Net Zero Energy Buildings, Federico Noris, Assunta Napolitano and Roberto Lollini, September 2013

Integration of Micro-Generation and Related Energy Technologies in Buildings – Annex 54

- An International Survey of Electrical and DHW Load Profiles for Use in Simulating the Performance of Residential Micro-cogeneration Systems, Ken Darcovich, Evgueniy Entchev, Peter Tzscheutschler, October 2014
- Current Updates on the Development and Implementation of Micro-Cogeneration System Models for Building Simulation Programs, Ken Darcovich, Evgueniy Entchev, Peter Tzscheutschler, October 2014
- Impact of Microgeneration Systems on the Low-Voltage Electricity Grid, Maurizio Sasso, Evgueniy Entchev, Peter Tzscheutschler, October 2014
- Methodologies for the Performance Assessment of Micro Hybrid Polygeneration Systems, Maurizio Sasso, Evgueniy Entchev, Peter Tzscheutschler, October 2014
- Synthesis Report on the Viability of Micro-Generation Systems in Different Operational Contexts, Maurizio Sasso, Evgueniy Entchev, Peter Tzscheutschler, October 2014
- A Comparative Review of Microgeneration Policy Instruments in OECD Countries, Adam Hawkes, Evgueniy Entchev, Peter Tzscheutschler, October 2014

- Impact of Support Mechanisms on Microgeneration Performance in OECD Countries, Adam Hawkes, Evgueniy Entchev, Peter Tzscheutschler, October 2014
- Integration of Microgeneration and Related Technologies in Buildings: Final Report, Evgueniy Entchev, Peter Tzscheutschler, October 2014

EBC Executive Committee Members

CHAIR

Andreas Eckmanns (Switzerland)

VICE CHAIR

Dr Takao Sawachi (Japan)

AUSTRALIA

Stefan Preuss
Sustainability Victoria
Stefan.Preuss@sustainability.vic.gov.au

AUSTRIA

Isabella Zwerger
Austrian Federal Ministry of Transport,
Innovation and Technology
Isabella.Zwerger@bmvit.gv.at

BELGIUM

Dr Peter Wouters
Belgian Building Research Institute
(CSTC – WTCB)
peter.wouters@bbri.be

CANADA

Dr Morad R Atif
National Research Council Canada
Morad.Atif@nrc-cnrc.gc.ca

P.R. CHINA

Prof Yi Jiang
Tsinghua University
jiangyi@tsinghua.edu.cn

CZECH REPUBLIC

To be confirmed

DENMARK

Rikke Marie Hald
The Danish Energy Agency
Ministry of Climate and Energy
rmh@ens.dk

FINLAND

Dr Riikka Holopainen
VTT Technical Research Centre of Finland
riikka.holopainen@vtt.fi

FRANCE

Pierre Héran
Agence de l'Environnement et de la Maitrise de
l'Energie
pierre.herant@ademe.fr

GERMANY

Markus Kratz
Forschungszentrum Jülich
m.kratz@fz-juelich.de

GREECE

To be confirmed

IRELAND

Brian O'Mahony
brian.omahony@seai.ie

ITALY

Michele Zinzi
ENEA - UTEE ERT
michele.zinzi@enea.it

JAPAN

Dr Takao Sawachi (Vice Chair)
National Institute for Land and
Infrastructure Management
sawachi-t92ta@nilim.go.jp

REPUBLIC OF KOREA

Dr Seung-eon Lee
Korea Institute of Construction Technology
selee2@kict.re.kr

NETHERLANDS

Daniël van Rijn
Netherlands Enterprise Agency
daniel.vanrijn@rvo.nl

NEW ZEALAND

Michael Donn
Victoria University of Wellington
michael.donn@vuw.ac.nz

NORWAY

Eline Skard
Department for Energy and Petroleum,
Norges Forskningsrad
eska@rcn.no

POLAND

Dr Eng Beata Majerska-Palubicka
Silesian University of Technology
beata.majerska-palubicka@polsl.pl

PORTUGAL

Prof Eduardo Maldonado
Universidade do Porto
ebm@fe.up.pt

SPAIN

Jose Maria Campos
Tecnalia Research & Innovation
josem.campos@tecnalia.com

SWEDEN

Conny Rolén
Formas
conny.rolen@formas.se

SWITZERLAND

Andreas Eckmanns (Chair)
Bundesamt für Energie BFE
andreas.eckmanns@bfe.admin.ch

UK

Prof Paul Ruyssevelt
University College London
p.ruyssevelt@ucl.ac.uk

USA

Mark Friedrichs
Department of Energy
mark.friedrichs@ee.doe.gov

EBC Operating Agents

Air Infiltration and Ventilation Centre (AIVC) – Annex 5

Dr Peter Wouters
INIVE EEIG
Belgium
info@aivc.org

Towards Net Zero Energy Solar Buildings (NZEBS) – Annex 52

Josef Ayoub
CanmetENERGY Research Centre, Canada
NetZeroBuildings@nrcan.gc.ca

Integration of Microgeneration and Other Energy Technologies in Buildings – Annex 54

Dr Evgueniy Entchev
CanmetENERGY Research Centre, Canada
eentchev@nrcan.gc.ca

Reliability of Energy Efficient Building Retrofitting – Probability Assessment of Performance & Cost – Annex 55

Dr Carl-Eric Hagentoft
Chalmers University of Technology, Sweden
carl-eric.hagentoft@chalmers.se

Cost Effective Energy and Carbon Emissions Optimization in Building Renovation – Annex 56

Dr Manuela Almeida
University of Minho, Portugal
malmeida@civil.uminho.pt

Evaluation of Embodied Energy and CO₂ Equivalent Emissions for Building Construction – Annex 57

Prof Tatsuo Oka
Utsunomiya University, Japan
okatatsuo@e-mail.jp

Reliable Building Energy Performance Characterisation Based on Full Scale Dynamic Measurements – Annex 58

Prof Staf Roels
University of Leuven, Belgium
staf.roels@bwk.kuleuven.be

High Temperature Cooling and Low Temperature Heating in Buildings – Annex 59

Prof Yi Jiang
Tsinghua University, P.R. China
jjiangyi@tsinghua.edu.cn

New Generation Computational Tools for Building and Community Energy Systems – Annex 60

Michael Wetter
Lawrence Berkeley National Laboratory, USA
mwetter@lbl.gov

Christoph van Treeck
RWTH Aachen University, Germany
treeck@e3d.rwth-aachen.de

Business and Technical Concepts for Deep Energy Retrofit of Public Buildings – Annex 61

Dr Alexander M. Zhivov
Energy Branch US Army Corps of Engineers, USA
Alexander.M.Zhivov@erdc.usace.army.mil

Rüdiger Lohse
KEA-Climate protection and energy agency of Baden-Württemberg GmbH, Germany
ruediger.lohse@kea-bw.de

Ventilative Cooling – Annex 62

Per Heiselberg
Aalborg University, Denmark
ph@civil.aau.dk

Implementation of Energy Strategies in Communities – Annex 63

Helmut Strasser
SIR - Salzburger Institut für Raumordnung und Wohnen, Austria
helmut.strasser@salzburg.gv.at

LowEx Communities – Optimised Performance of Energy Supply Systems with Exergy Principles – Annex 64

Dr. Dietrich Schmidt
Fraunhofer Institute for Building Physics, Germany
dietrich.schmidt@ibp.fraunhofer.de

Long-Term Performance of Super-Insulating Materials in Building Components and Systems – Annex 65

Daniel Quenard
Centre Scientifique et Technique du Bâtiment, France
daniel.quenard@cstb.fr

Definition and Simulation of Occupant Behavior in Buildings – Annex 66

Dr Da Yan
Tsinghua University, P.R. China
yanda@tsinghua.edu.cn

Dr Tianzhen Hong
Lawrence Berkeley National Laboratory, USA
thong@lbl.gov

Energy Flexible Buildings – Annex 67

Søren Østergaard Jensen
Danish Technological Institute, Denmark
sdj@teknologisk.dk

Design and Operational Strategies for High IAQ in Low Energy Buildings – Annex 68

Prof Carsten Rode
Technical University of Denmark, Denmark
car@byg.dtu.dk

Strategy and Practice of Adaptive Thermal Comfort in Low Energy Buildings – Annex 69

Prof Yingxin Zhu
Tsinghua University, P.R. China
zhuyx@tsinghua.edu.cn

EBC Executive Committee Support and Services Unit (ESSU)

Malcolm Orme
essu@iea-ebc.org

IEA Secretariat

Marc LaFrance
Marc.LAFRANCE@iea.org

Past Projects

- Annex 1 Load Energy Determination of Buildings
- Annex 2 Ekistics and Advanced Community Energy Systems
- Annex 3 Energy Conservation in Residential Buildings
- Annex 4 Glasgow Commercial Building Monitoring
- Annex 6 Energy Systems and Design of Communities
- Annex 7 Local Government Energy Planning
- Annex 8 Inhabitants Behaviour with Regard to Ventilation
- Annex 9 Minimum Ventilation Rates
- Annex 10 Building HVAC System Simulation
- Annex 11 Energy Auditing
- Annex 12 Windows and Fenestration
- Annex 13 Energy Management in Hospitals
- Annex 14 Condensation and Energy
- Annex 15 Energy Efficiency in Schools
- Annex 16 BEMS 1-User Interfaces and System Integration
- Annex 17 BEMS 2-Evaluation and Emulation Techniques
- Annex 18 Demand Controlled Ventilation Systems
- Annex 19 Low Slope Roof Systems
- Annex 20 Air Flow Patterns within Buildings
- Annex 21 Thermal Modelling
- Annex 22 Energy Efficient Communities
- Annex 23 Multi Zone Air Flow Modelling (COMIS)
- Annex 24 Heat, Air and Moisture Transfer in Envelopes
- Annex 25 Real time HEVAC Simulation
- Annex 26 Energy Efficient Ventilation of Large Enclosures
- Annex 27 Evaluation and Demonstration of Domestic Ventilation Systems
- Annex 28 Low Energy Cooling Systems
- Annex 29 Daylight in Buildings
- Annex 30 Bringing Simulation to Application
- Annex 31 Energy-Related Environmental Impact of Buildings
- Annex 32 Integral Building Envelope Performance Assessment
- Annex 33 Advanced Local Energy Planning
- Annex 34 Computer-Aided Evaluation of HVAC System Performance
- Annex 35 Design of Energy Efficient Hybrid Ventilation (HYBVENT)
- Annex 36 Retrofitting of Educational Buildings
- Annex 37 Low Exergy Systems for Heating and Cooling of Buildings (LowEx)
- Annex 38 Solar Sustainable Housing
- Annex 39 High Performance Insulation Systems
- Annex 40 Building Commissioning to Improve Energy Performance
- Annex 41 Whole Building Heat, Air and Moisture Response (MOIST-ENG)
- Annex 42 The Simulation of Building-Integrated Fuel Cell and Other Cogeneration Systems (FC+COGEN-SIM)
- Annex 43 Testing and Validation of Building Energy Simulation Tools
- Annex 44 Integrating Environmentally Responsive Elements in Buildings
- Annex 45 Energy Efficient Electric Lighting for Buildings
- Annex 46 Holistic Assessment Tool-kit on Energy Efficient Retrofit Measures for Government Buildings (EnERGo)
- Annex 47 Cost-Effective Commissioning for Existing and Low Energy Buildings
- Annex 48 Heat Pumping and Reversible Air Conditioning
- Annex 49 Low Exergy Systems for High Performance Buildings and Communities
- Annex 50 Prefabricated Systems for Low Energy Renovation of Residential Buildings
- Annex 51 Energy Efficient Communities: Case Studies and Strategic Guidance for Urban Decision Makers
- Annex 52 Towards Net Zero Energy Solar Buildings (NZEBS)
- Annex 53 Total Energy Use in Buildings – Analysis and Evaluation Methods
- Annex 54 Integration of Microgeneration and Other Energy Technologies in Buildings



EBC is a programme of the International Energy Agency (IEA)