

Impact of PV inverters on voltage profiles – mitigation with local voltage control

¹B. Bletterie; ¹A. Goršek; ²M. Heidl; ³A. Abart

¹AIT Austrian Institute of Technology, Energy Department, Electric Energy Systems, Giefinggasse 2, 1210 Wien
²Fronius International GmbH, Günter Fronius Straße 1, 4600 Thalheim bei Wels
³Energie AG Oberösterreich Netz GmbH, Bahnhofstrasse 67, 4810 Gmunden

INTRODUCTION

Several attempts to perform studies aiming at quantifying the impacts of distributed generation or investigating possible control schemes to mitigate these impacts lead to interesting results [1] but are partly based on limiting assumptions due to the lack of data. Assuming for example load and generation symmetry can be considered as a sound assumption for studies in the MV network but leads to biased results in LV networks. Furthermore, the use of synthetic load profiles (representing the aggregation of a sufficient number of customers) is justifiable for MV studies but leads to idealistic results for LV studies.

The results presented here are based on unsymmetrical load flow computations made for several weeks with a time step of 1 s. For the study, a three-phase four wire model of the rural network has been developed used. Consumption data (1 s-three-phase measurements for more than 30 households) were provided by the project ADRES [2] and PV generation profiles have been generated on the basis of 1 s-irradiance and temperature measurements.

The results presented here are based on a real data and sound assumptions. They can however not be generalized due to the inhomogeneity of LV networks.

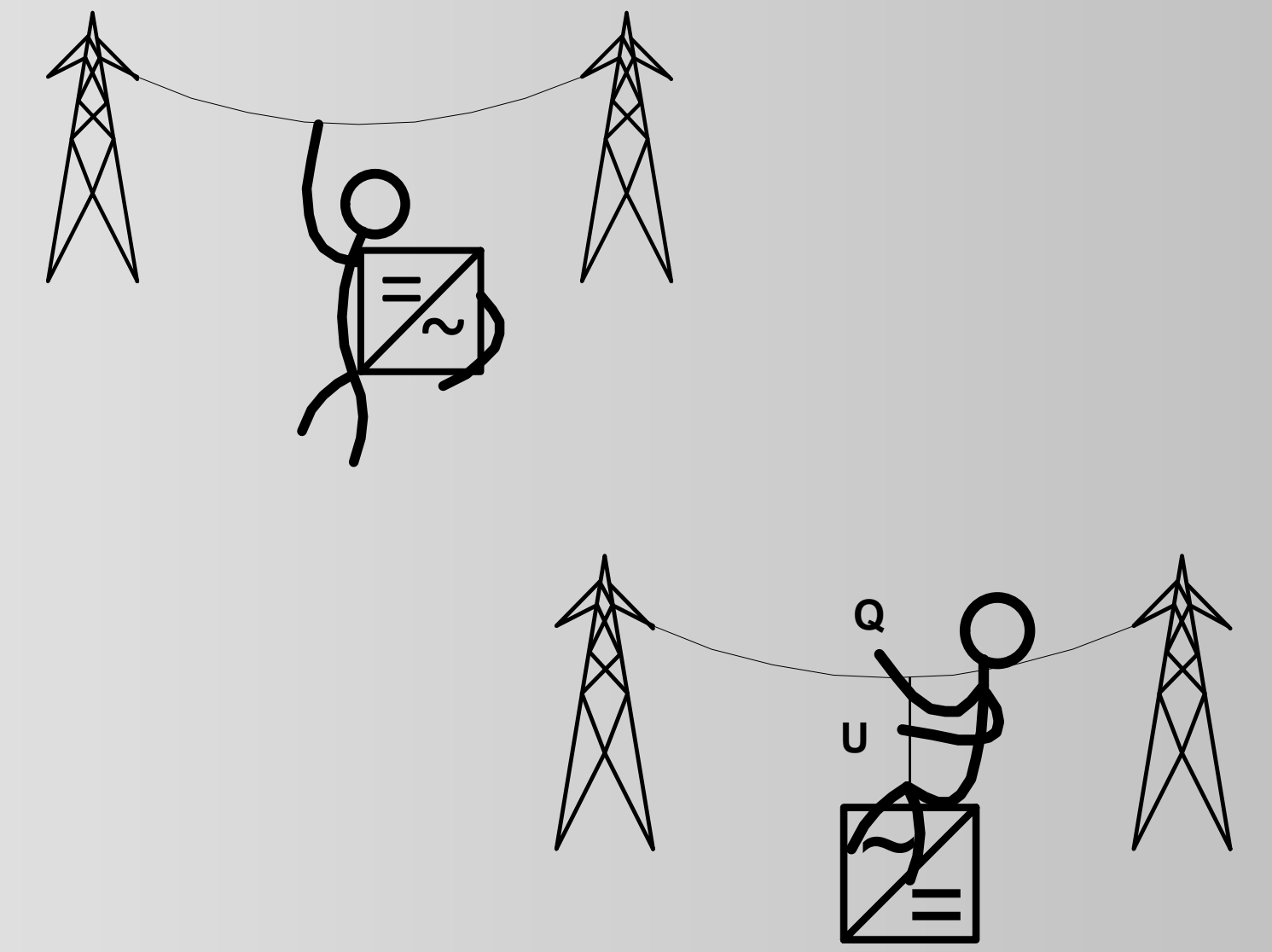

CONSIDERED NETWORK, METHODOLOGY

Network characteristics:

- Transformer nominal power: 100 kVA
- Longest feeder: ~ 950 m
- Three-phase four wire modelling
- PV generators: 20 × 3 kW (“randomly” distributed over nodes and phases: 7 on L1, 9 on L2, 4 on L3)
 → very high penetration (>> hosting capacity acc. to current planning rules)
- Simulations based on 1 s-values for loads and PV generators



Abb. 1. Network overview

CASE STUDY ON THE IMPACT OF UNBALANCED INFEEED

- Study for the longest feeder with 7 PV generators.
- All possible combinations ($3^7=2187$) computed by script-automated power flow

Computed voltage rise ΔU :

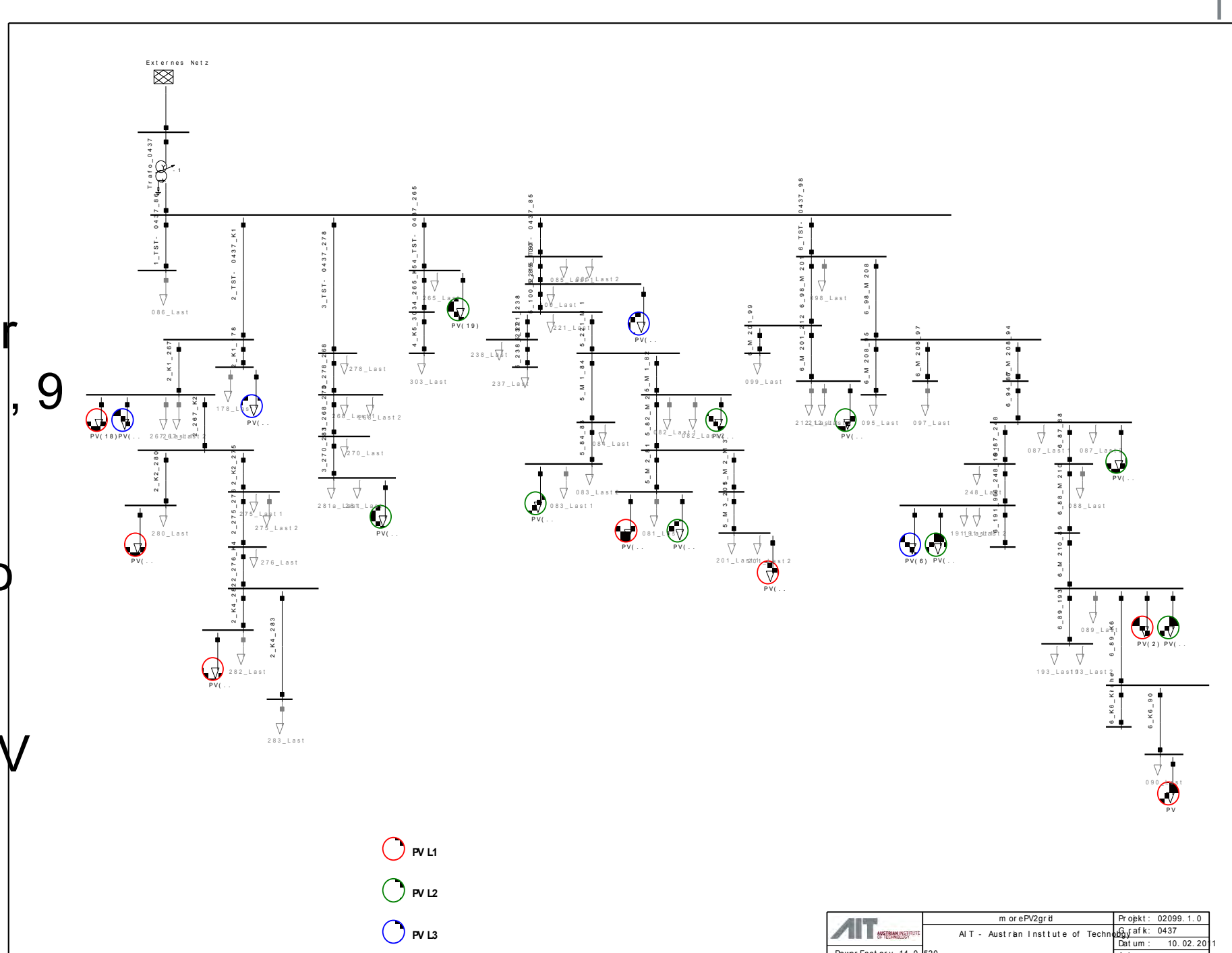
- best-case: 2,4 %
- worst-case: 9,5 %
- actual configuration: 5,5 %
- “residual unbalance”: 7,1 % (“pragmatic best-worst-case” based on TOR D2, [3])
 → represents 95 % percentile in this case



Abb. 2. Voltage rise from unbalanced infeed

VOLTAGE CONTROL $\cos(\varphi) = konst. / \cos(\varphi) = f(P)$

$\cos(\varphi) = f(P)$: potential stability problems due to the inflexion point around 1.

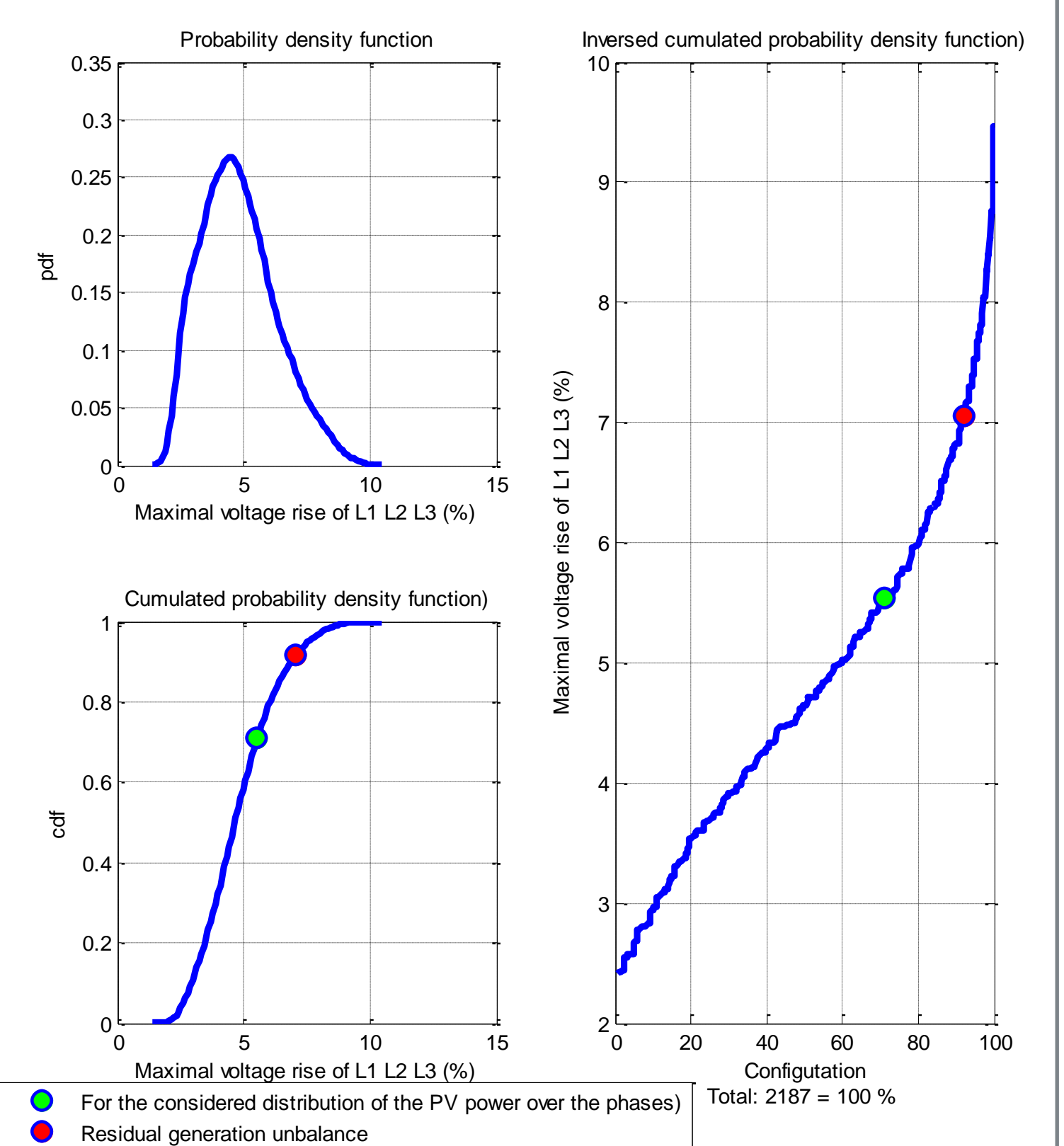

Abb. 3. Characteristic-based voltage rise mitigation (“open loop”)

VOLTAGE CONTROL $Q = f(U)$

Coordination between generators must be investigated (risk of oscillations). The settings used here ($\Delta U_{DB}=2\%$ and $\Delta U_{MAX}=5\%$) were chosen to allow a good visualisation. Suitable settings will be proposed in the course of the project.

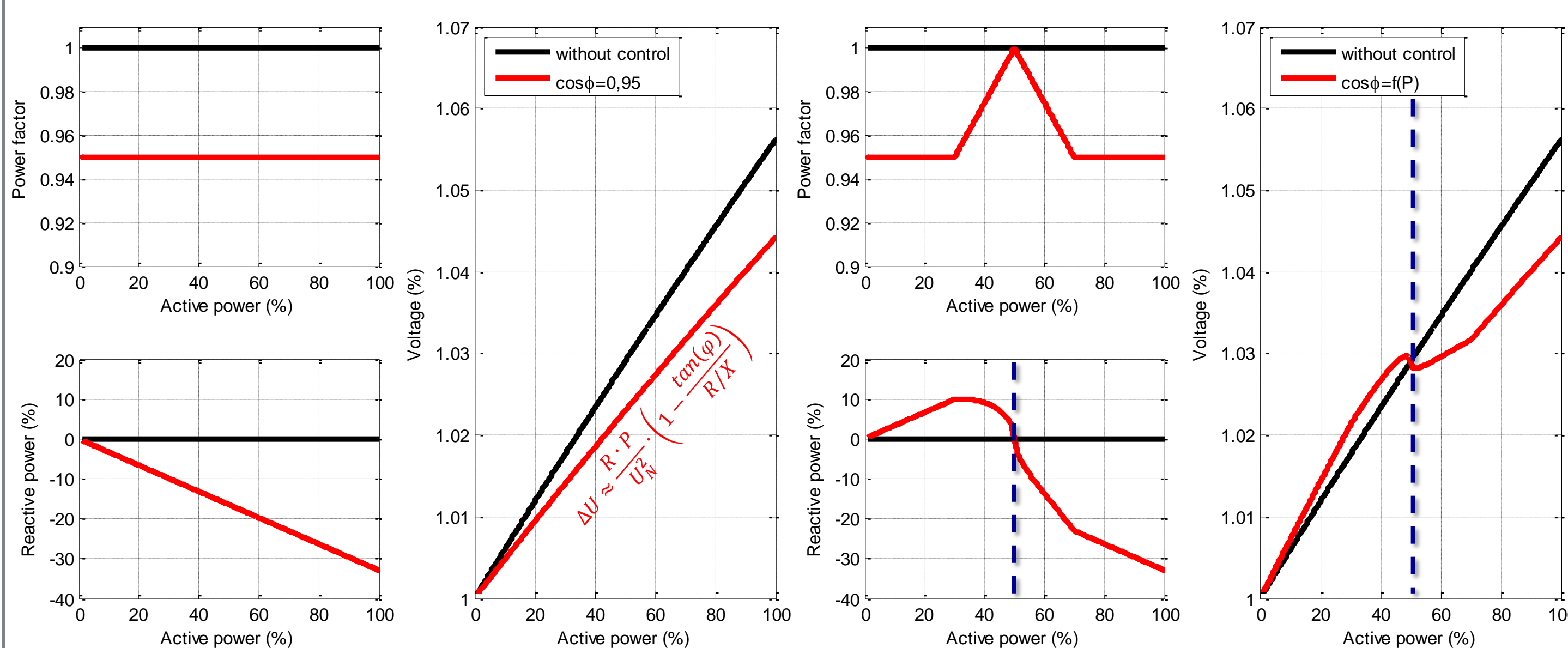

Abb. 4. Characteristic-based voltage rise mitigation (“closed loop”)

VOLTAGE CONTROL EFFECTIVENESS IN LV NETWORKS

Voltage sensitivity of the 0.4 kV nodes

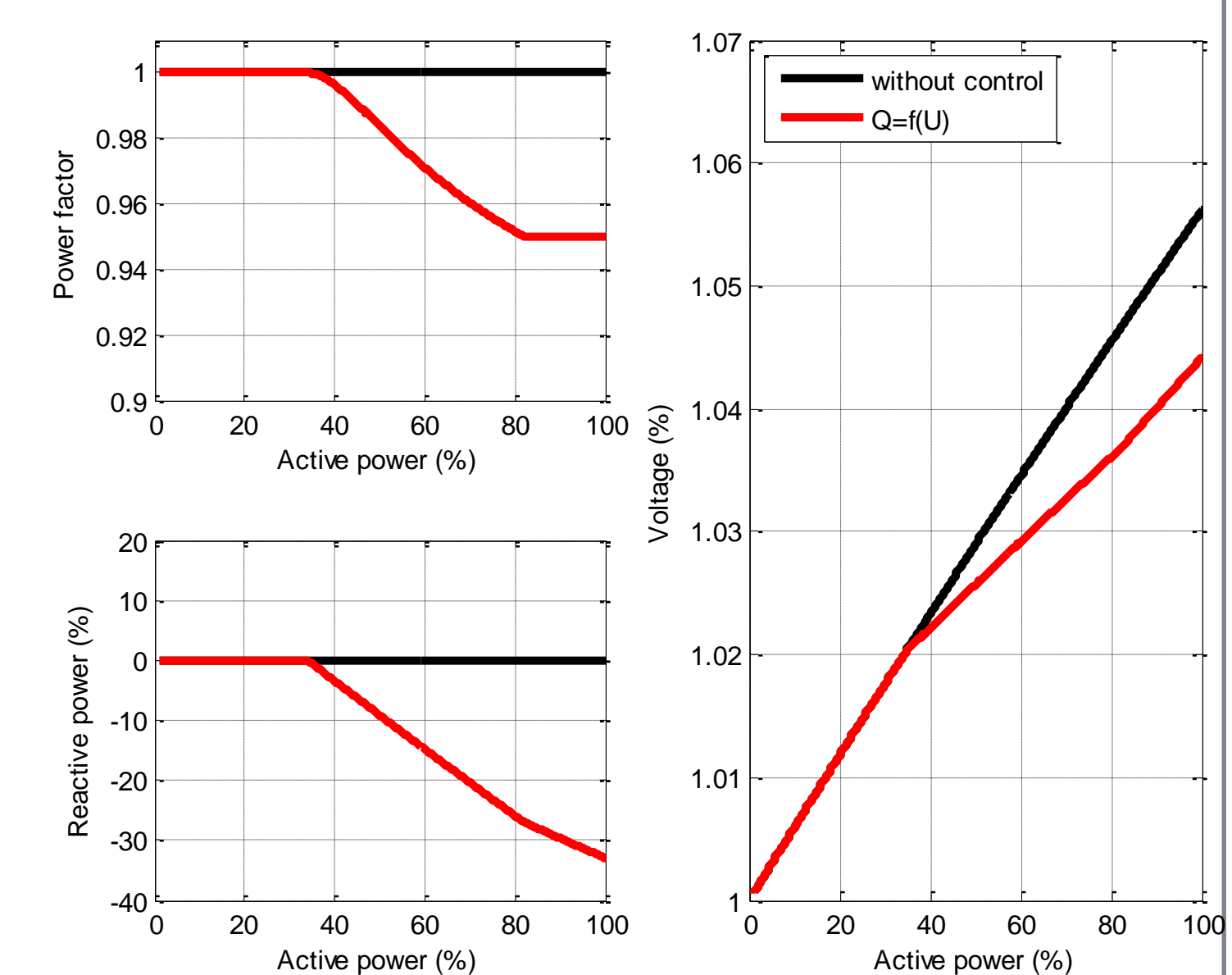
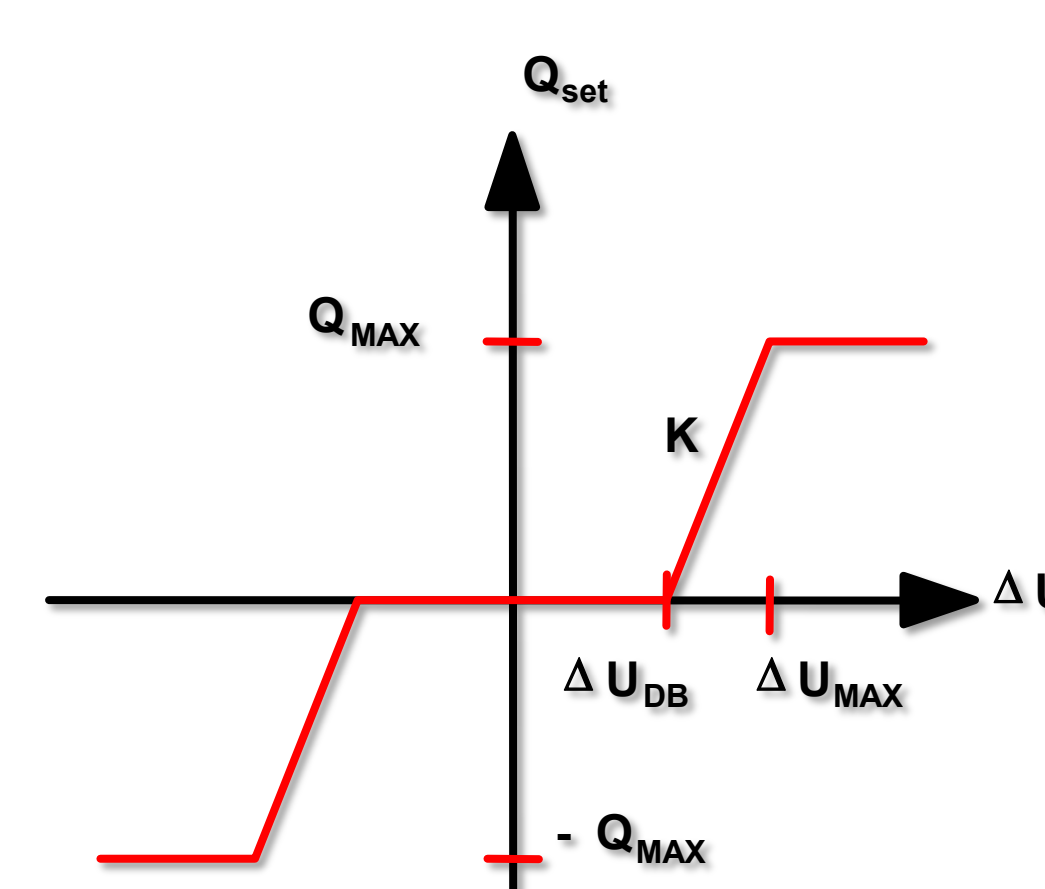
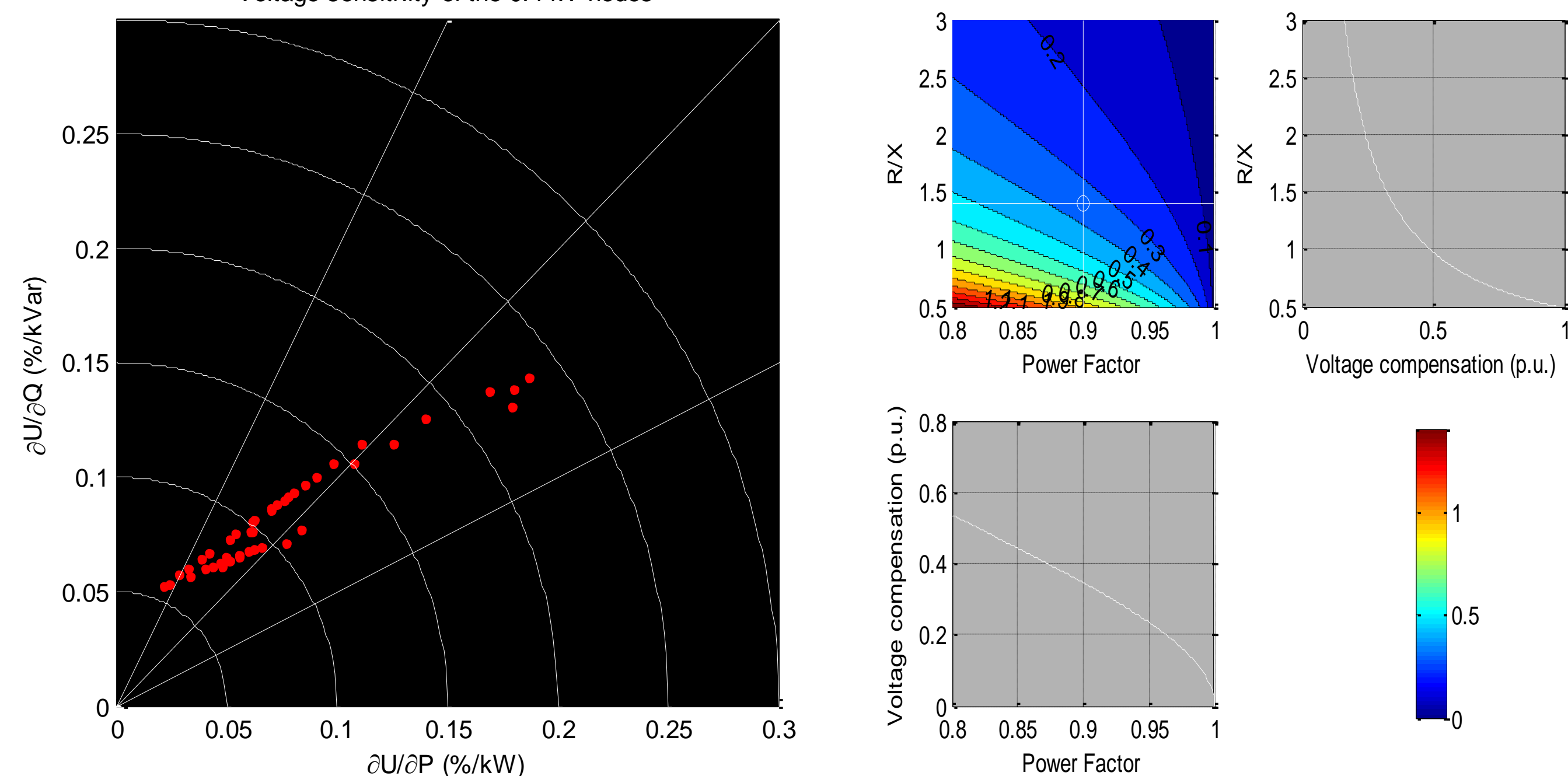

Abb. 5. Voltage control effectiveness at the weakest node

CONCLUSIONS AND OUTLOOK

The following conclusions can be drawn (based on the considered network):

- Depending on the assumptions on the distribution of the PV power on the three phases, the bandwidth of the voltage rise reaches here about 7 %.
- Due to the lack of information, conservative assumptions are used. In the near future, phase information may be available at each point of connection and thus
- The procedure used to assess the connection of single-phase generators “residual unbalance” corresponds to the 95 % percentile.
- The voltage rise caused by PV generators is partly compensated (~ 1 %) by loads. This applies only for the 10 minutes values (not for 1 s values).
- The effectiveness of voltage control depends on the R/X ratio of the grid impedance. Weak nodes usually exhibit a R/X ratio >1 in LV networks.
- The voltage control characteristic Q(U) is currently investigated into details (steady-state and dynamic properties). The objective is to propose a set of suitable settings from the network and inverter perspective.