

FFG
FORSCHUNG WIRKT.



EUWP Workshop
From Energy Efficient Buildings to Smart Cities

Heating and Cooling in a Smart City

Hermann Halozan
Graz University of Technology

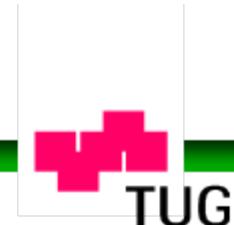



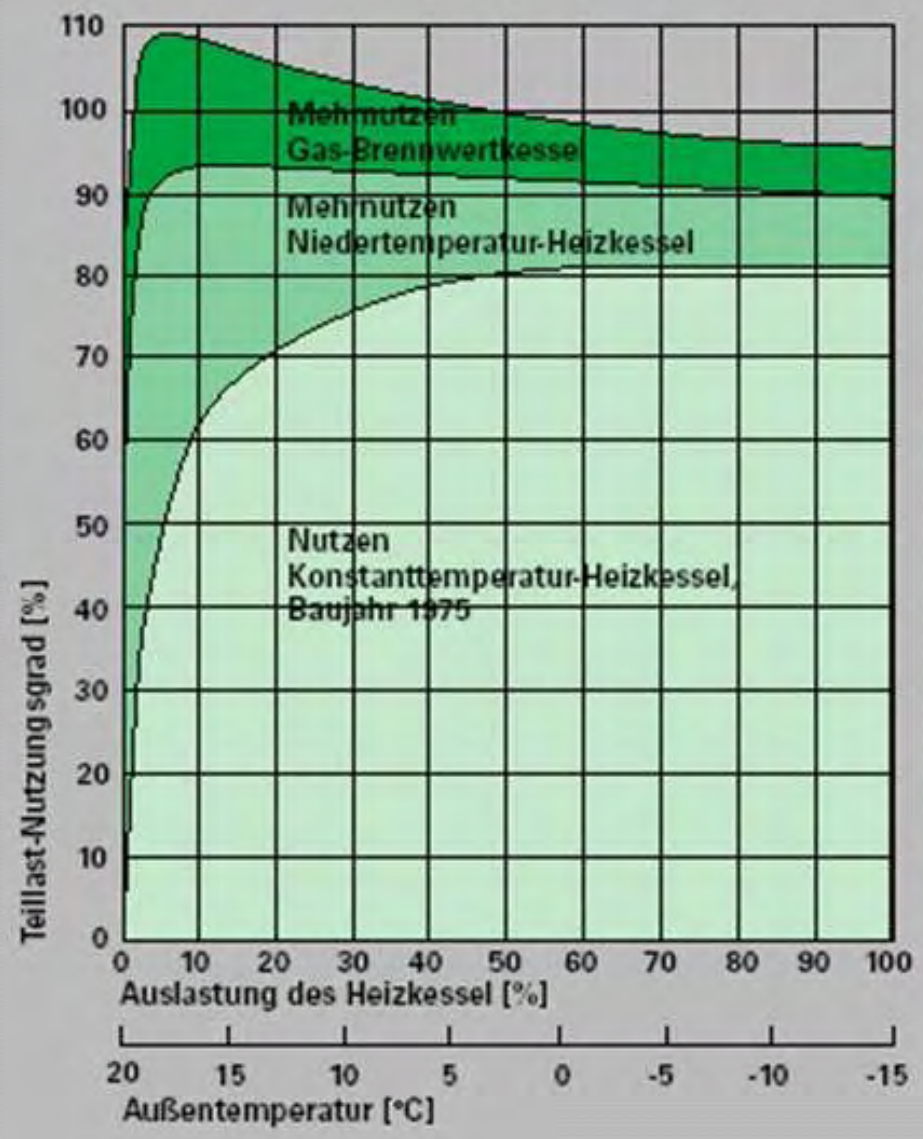
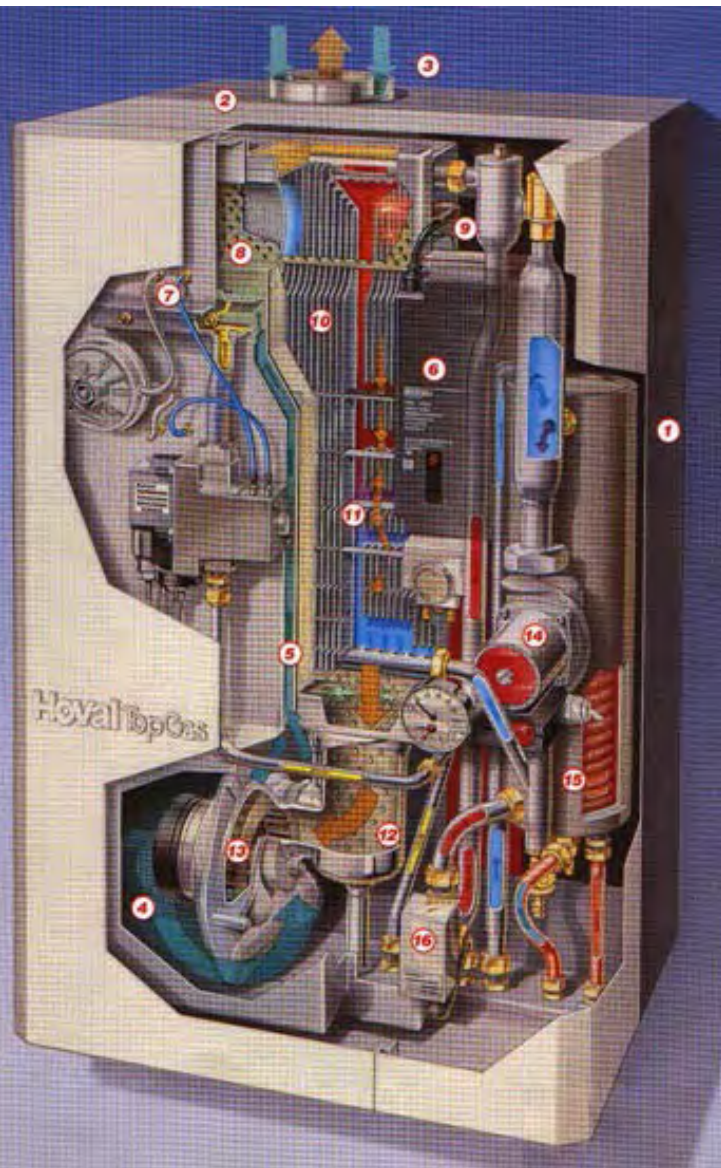





(c) www.airpix.at

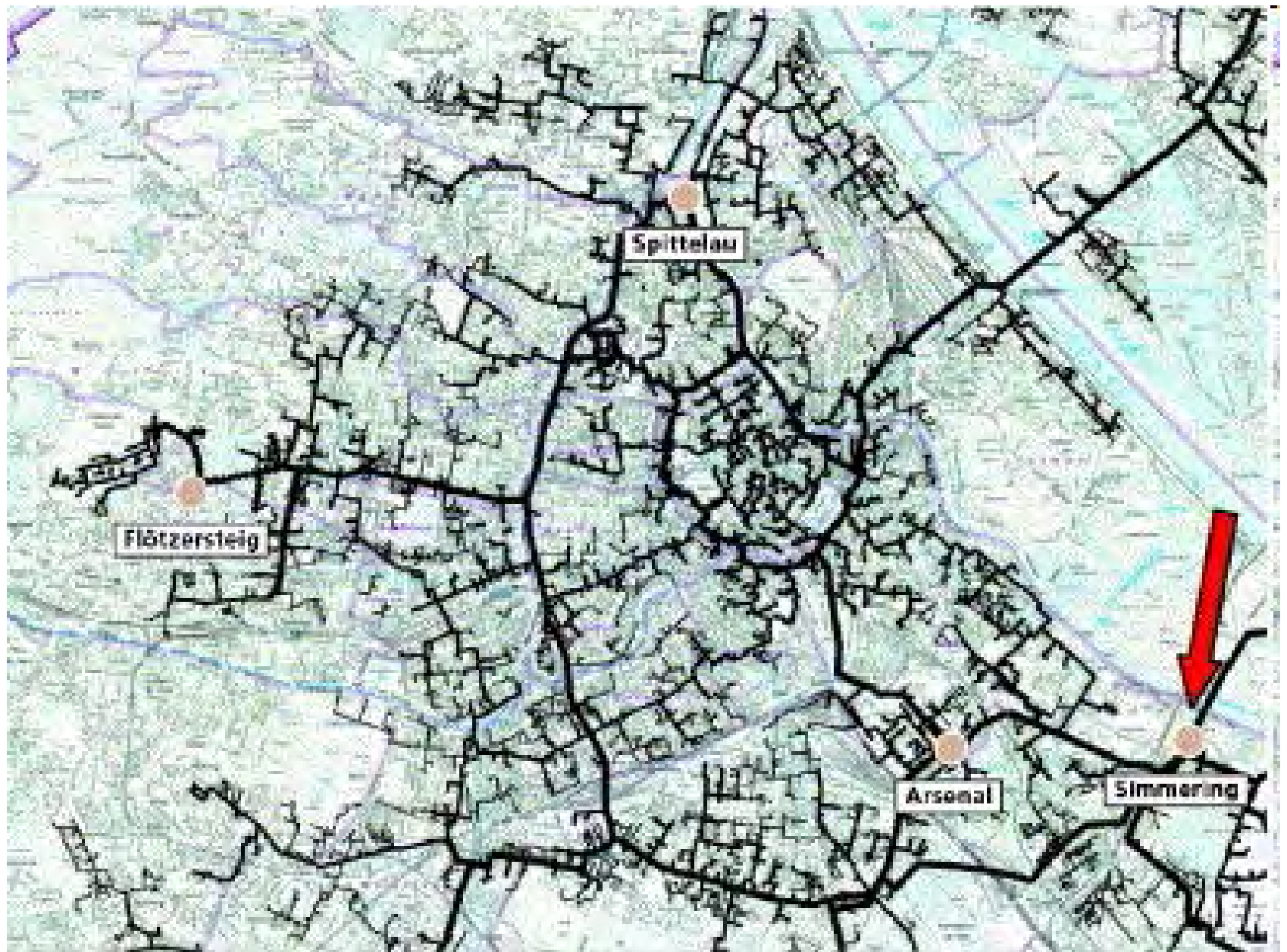





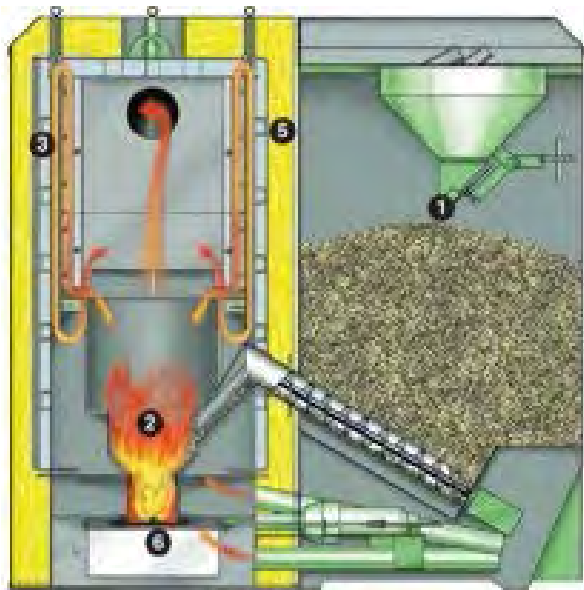
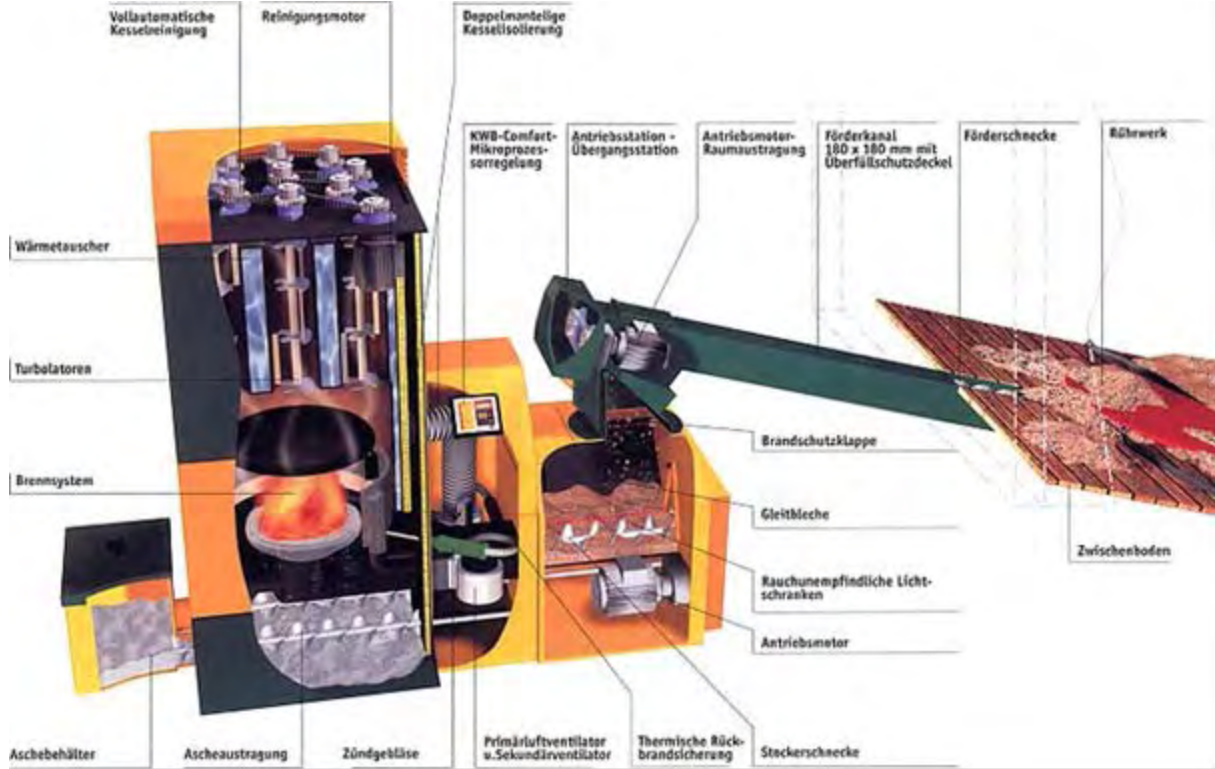

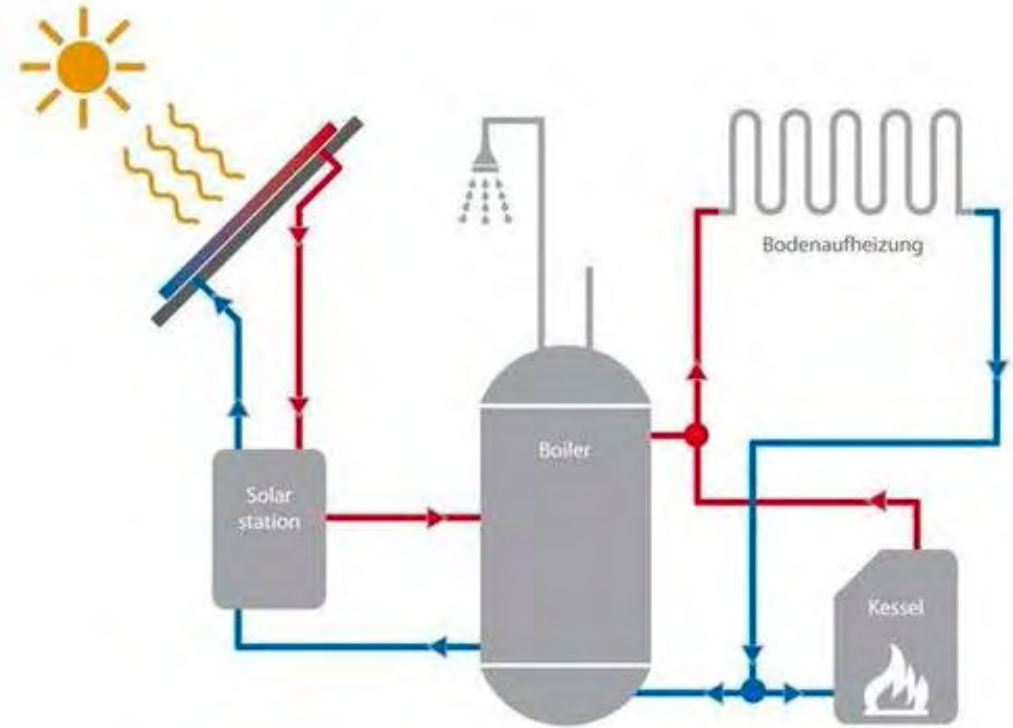
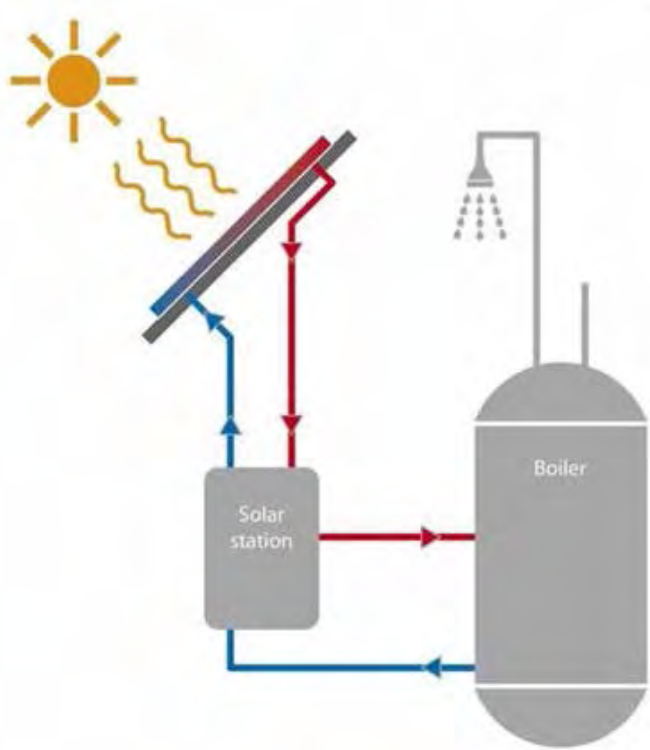

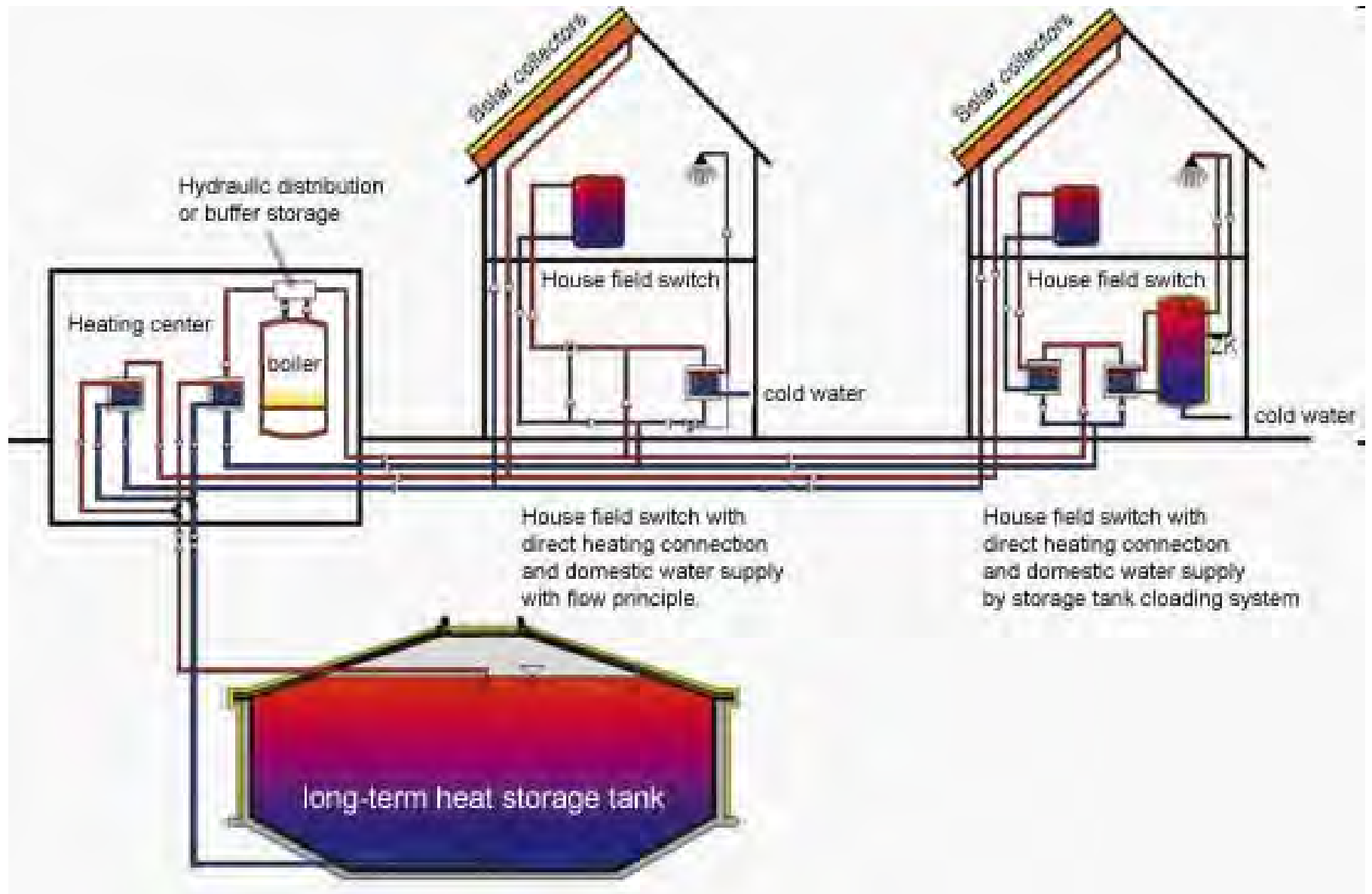

House field switch with direct heating connection and domestic water supply with flow principle.

House field switch with direct heating connection and domestic water supply by storage tank cloading system



Carnot, Sadi (1796-1832)

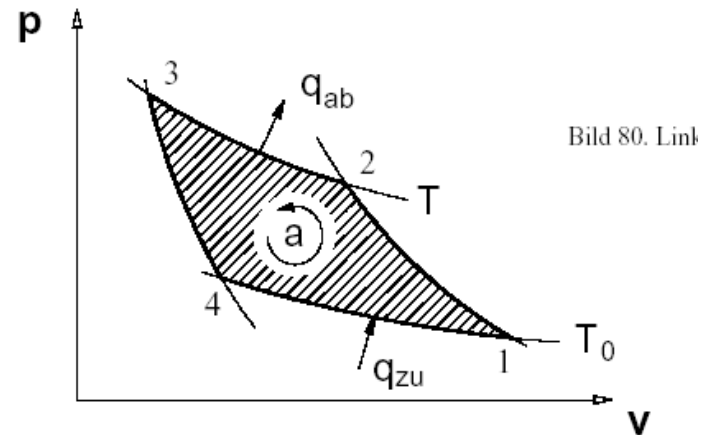
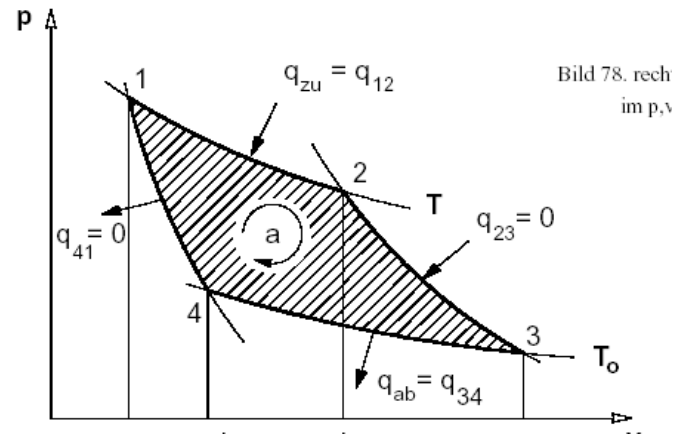

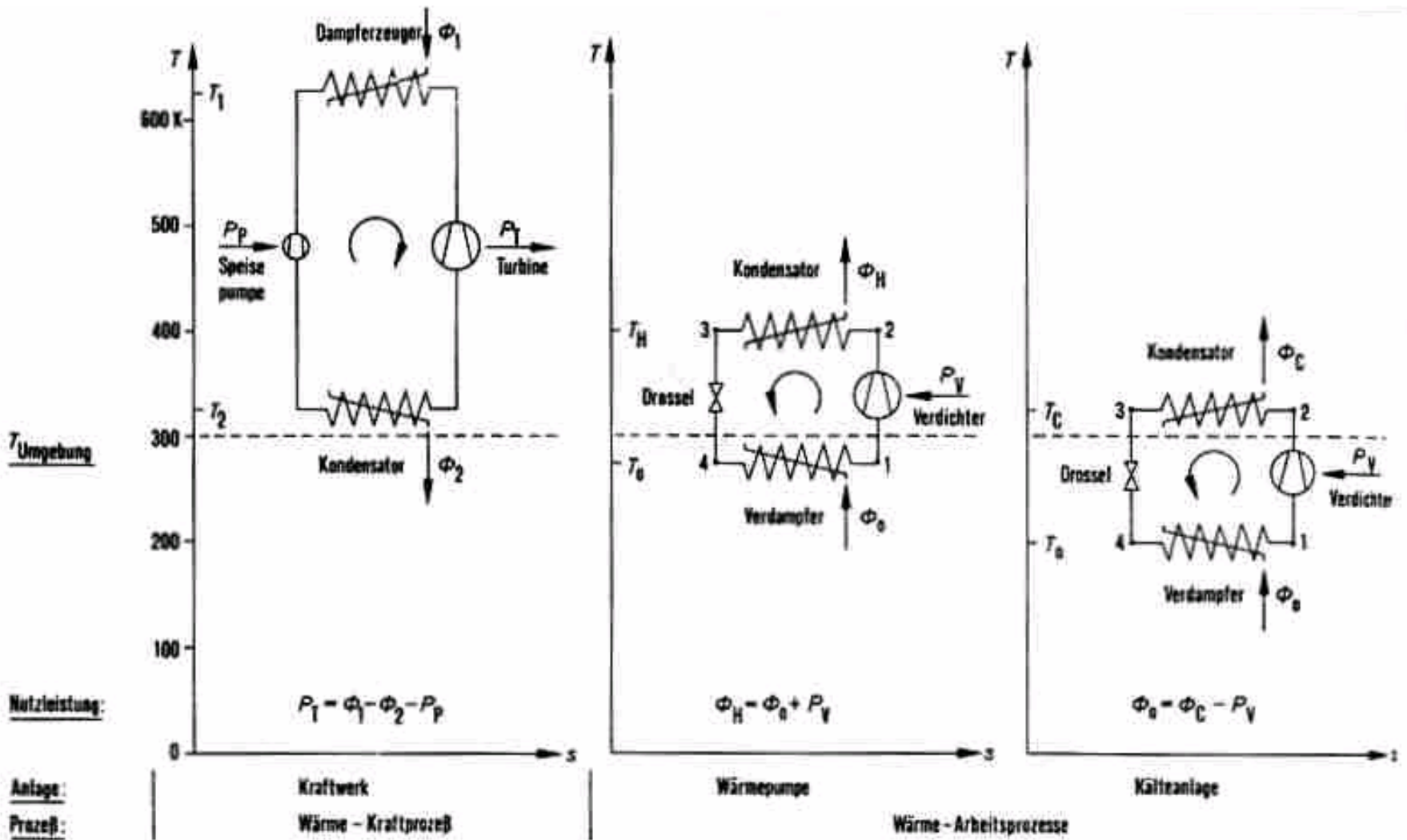

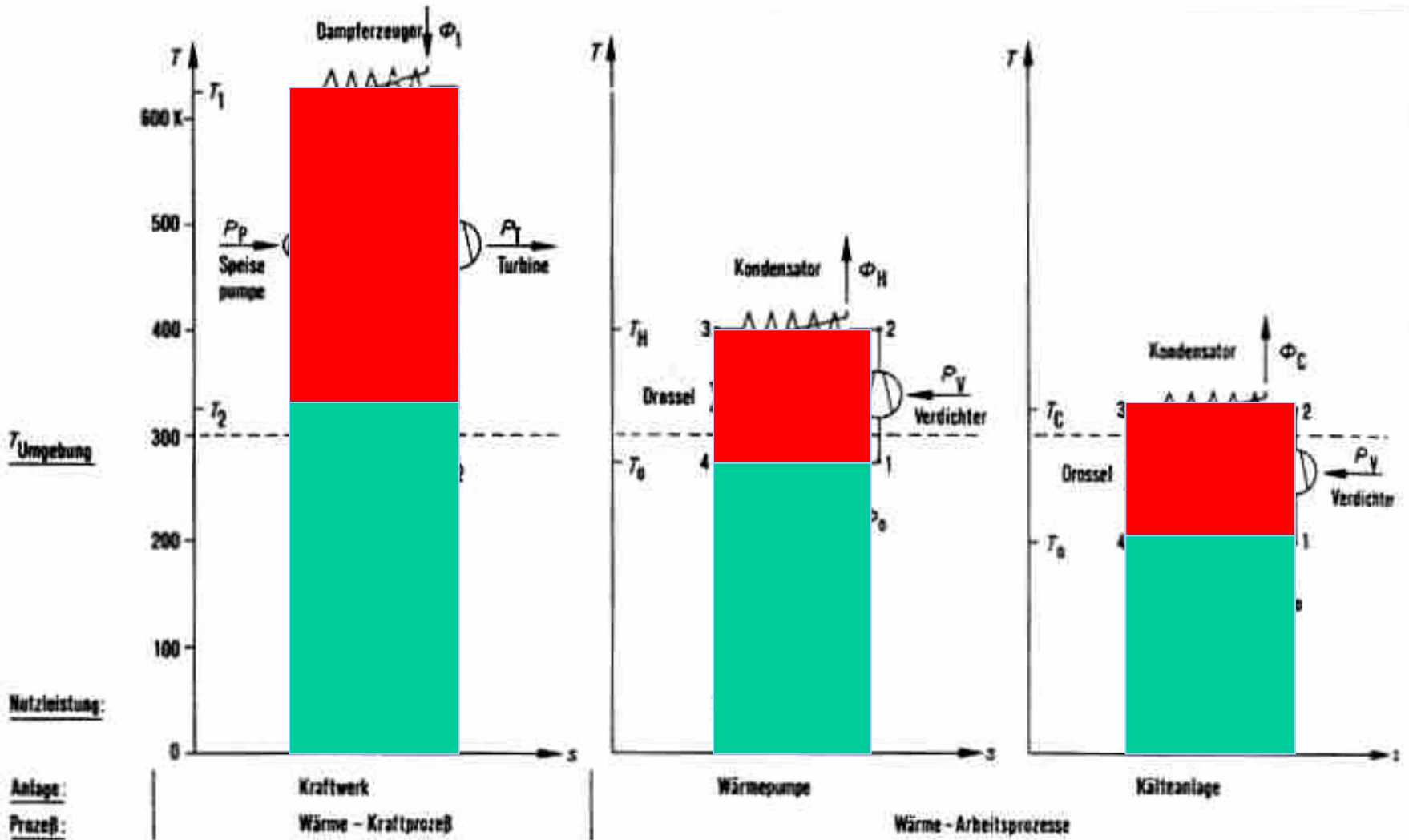

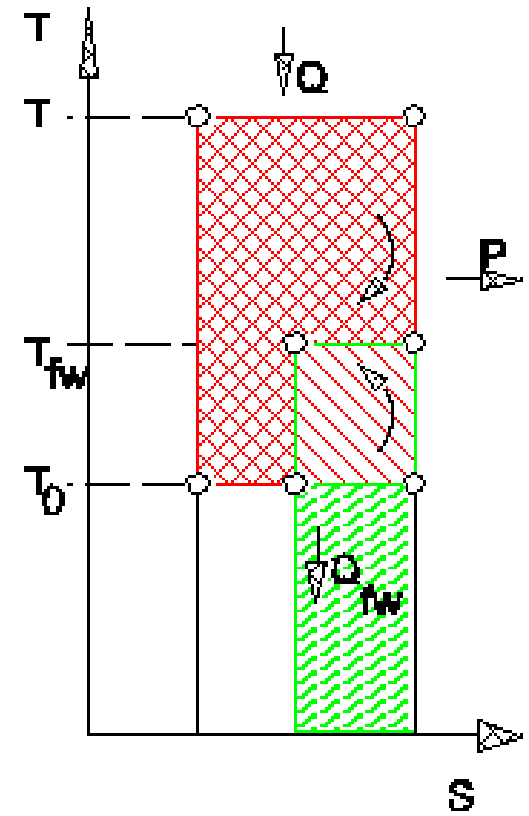
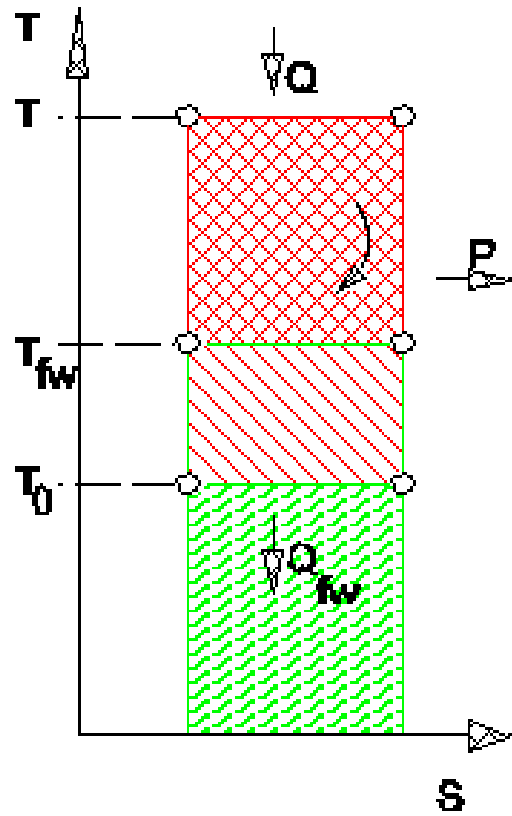
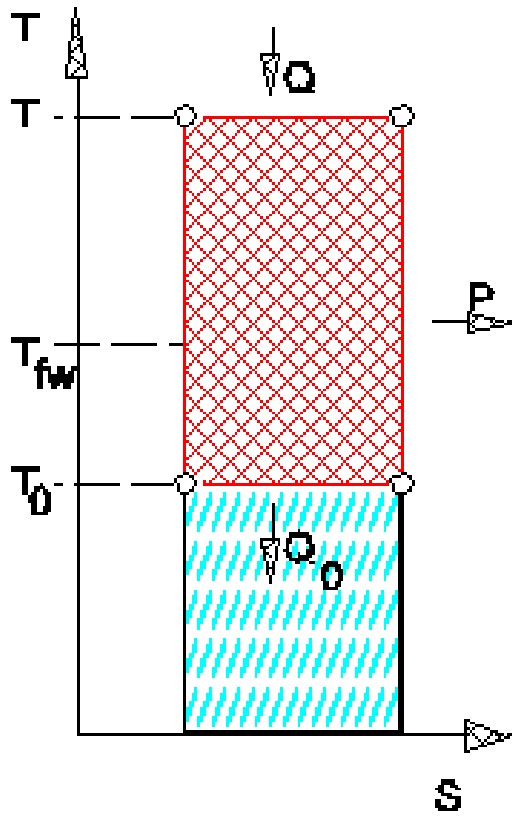

Ideal and Real Power Consumption E_x/Q for Refrigeration and Air Conditioning and Space Heating by Heat Pumps and by Cogeneration

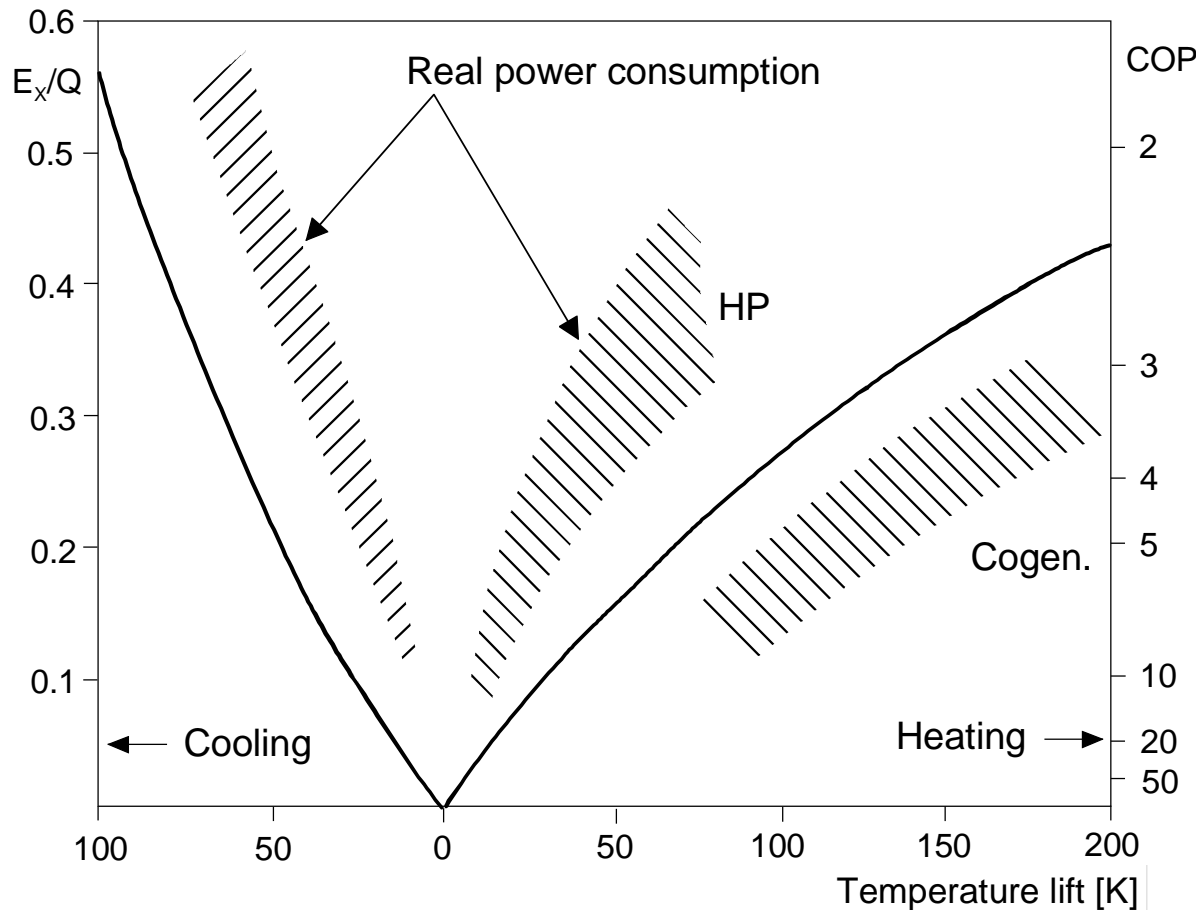

Typical Primary and Useful Energy Ratios

$$UER = (PER/\eta_B)(\eta_{d,,el}/\eta_{d,fuel})$$

	Coal (and Biomass)	Gas	Electricity from Renewables (hydro, wind)	Nuclear
<u>Efficiencies</u>				
Power plant, η_{PP}	0.4	0.55	1.0	0.33
Boiler (local conversion), η_B	0.8	0.98	1.0	1.0
<u>PER for SPF = 4</u>				
PER = SPF. η_{PP}	1.6	2.20	4.0	1.33
UER = PER/ η_B	2.0	2.24	4.0	1.33
<u>PER for SPF = 5</u>				
PER = SPF. η_{PP}	2.0	2.75	5.0	1.67
UER = PER/ η_B	2.5	2.81	5.0	1.67

Renewable Energy Gained

$$R = Q - E = Q - Q/SPF = Q(1 - 1/SPF)$$



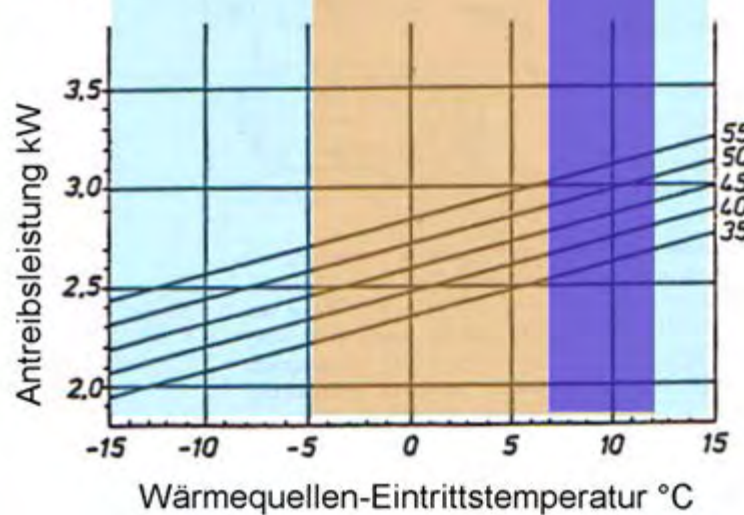
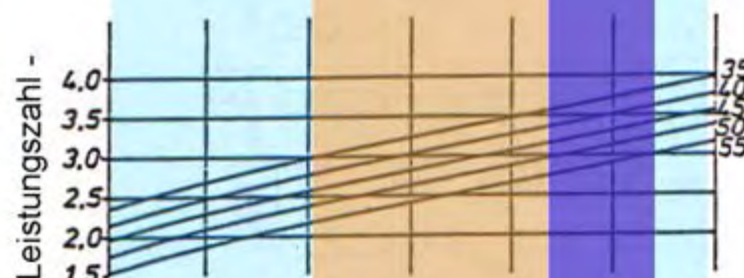
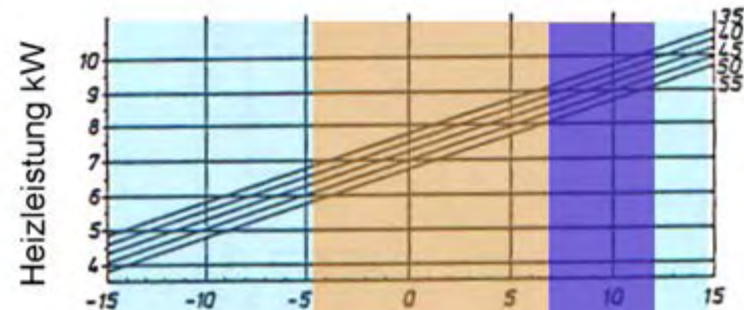
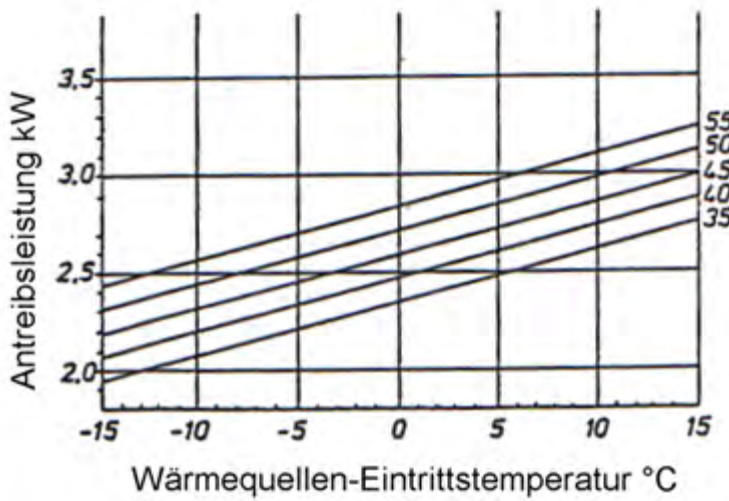
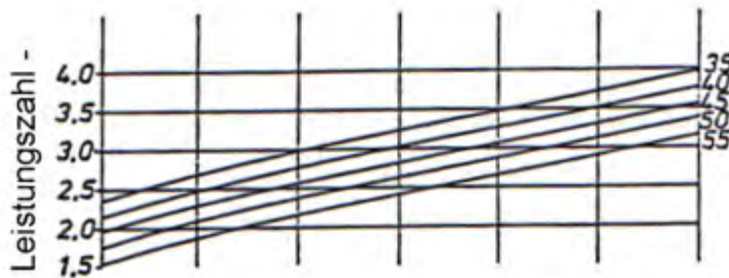
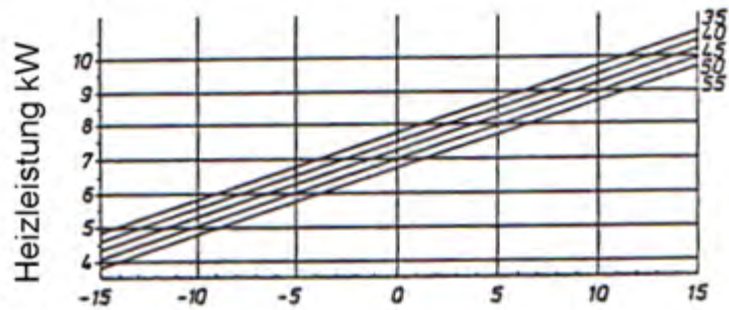

Wärmepumpen-Austrittstemperatur °C

Wärmepumpen-Austrittstemperatur °C

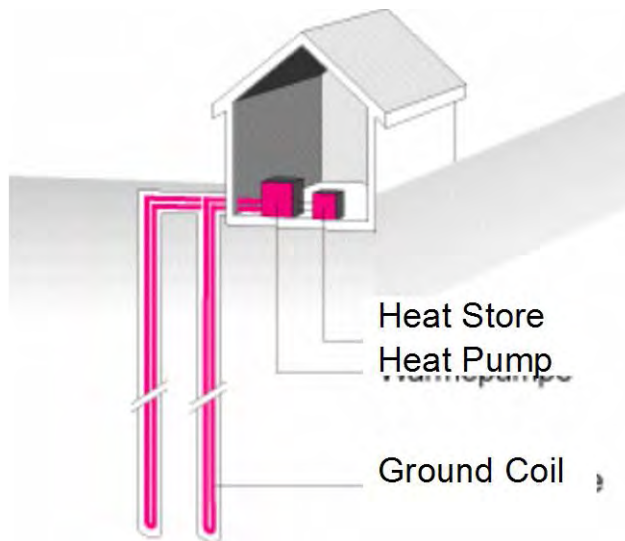
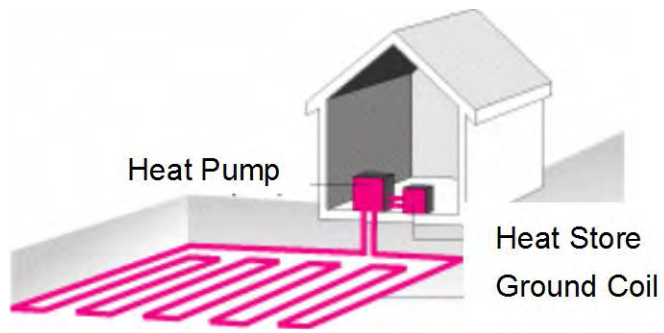

Vertical Installed System

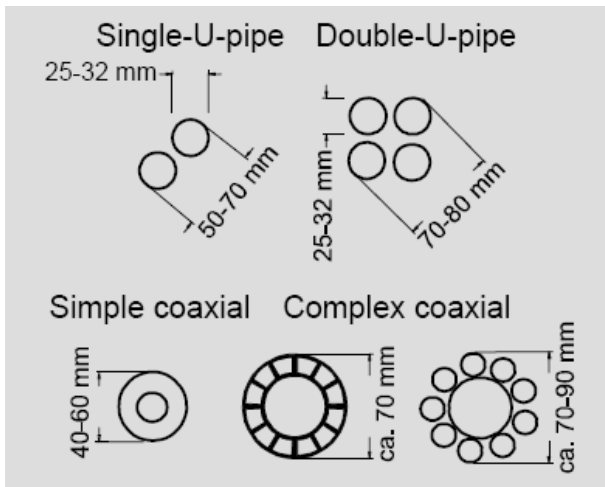
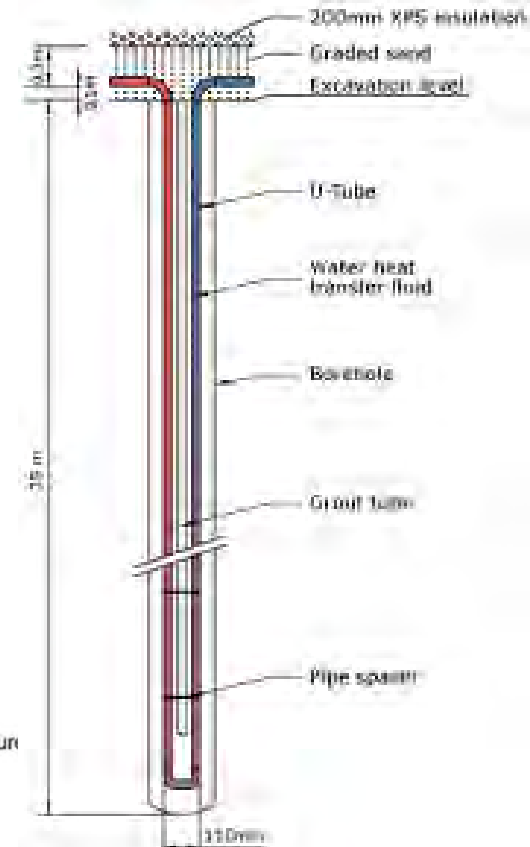
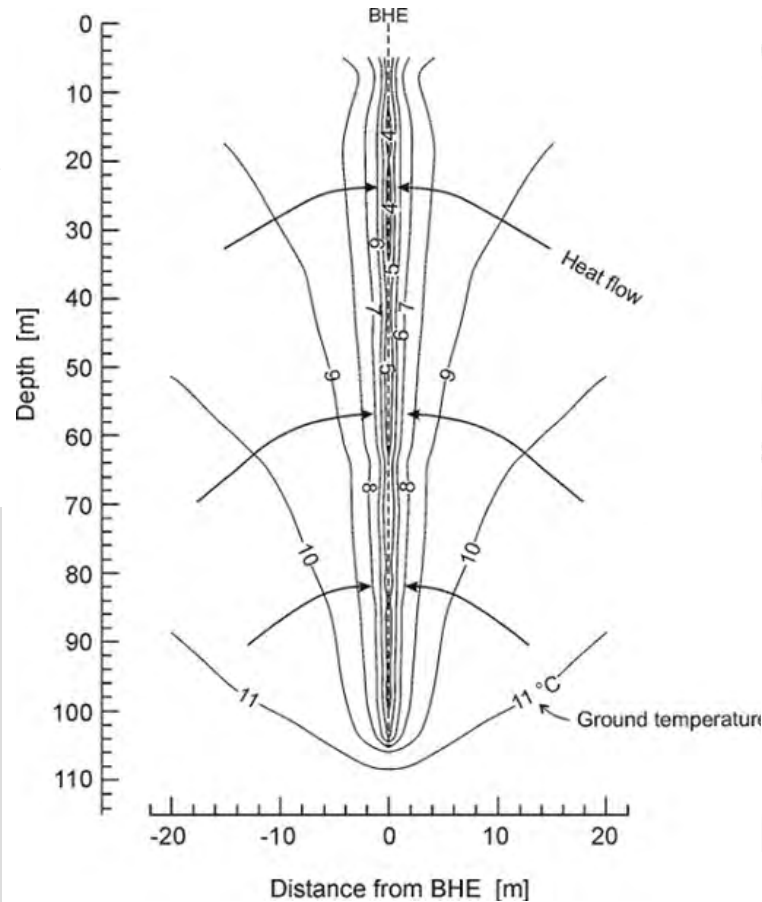
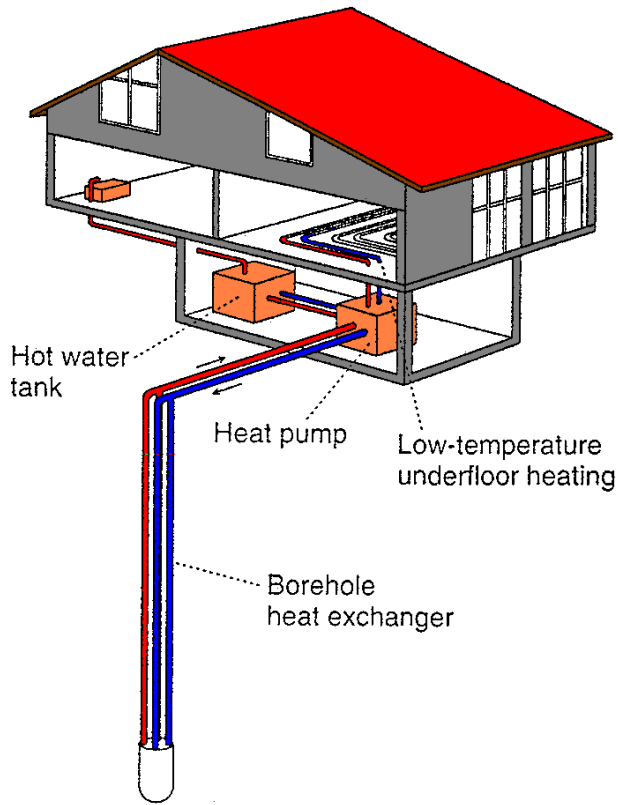

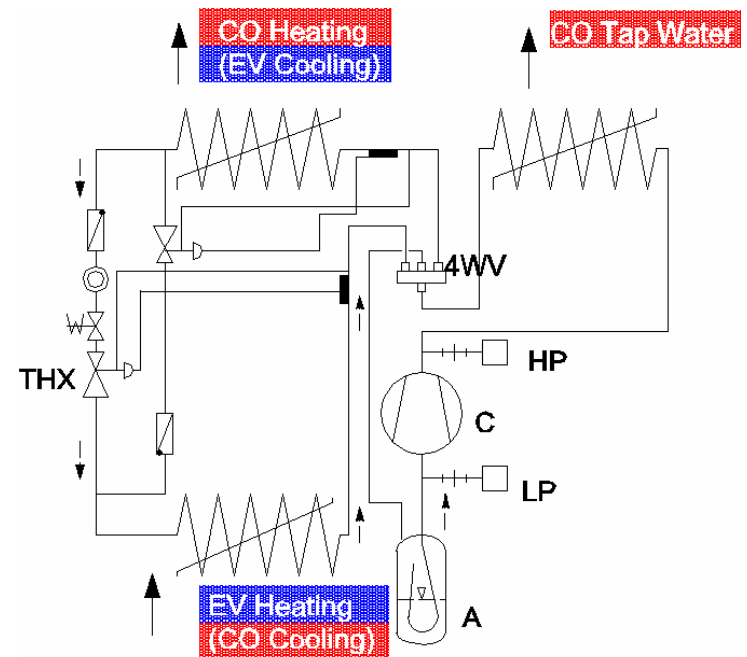
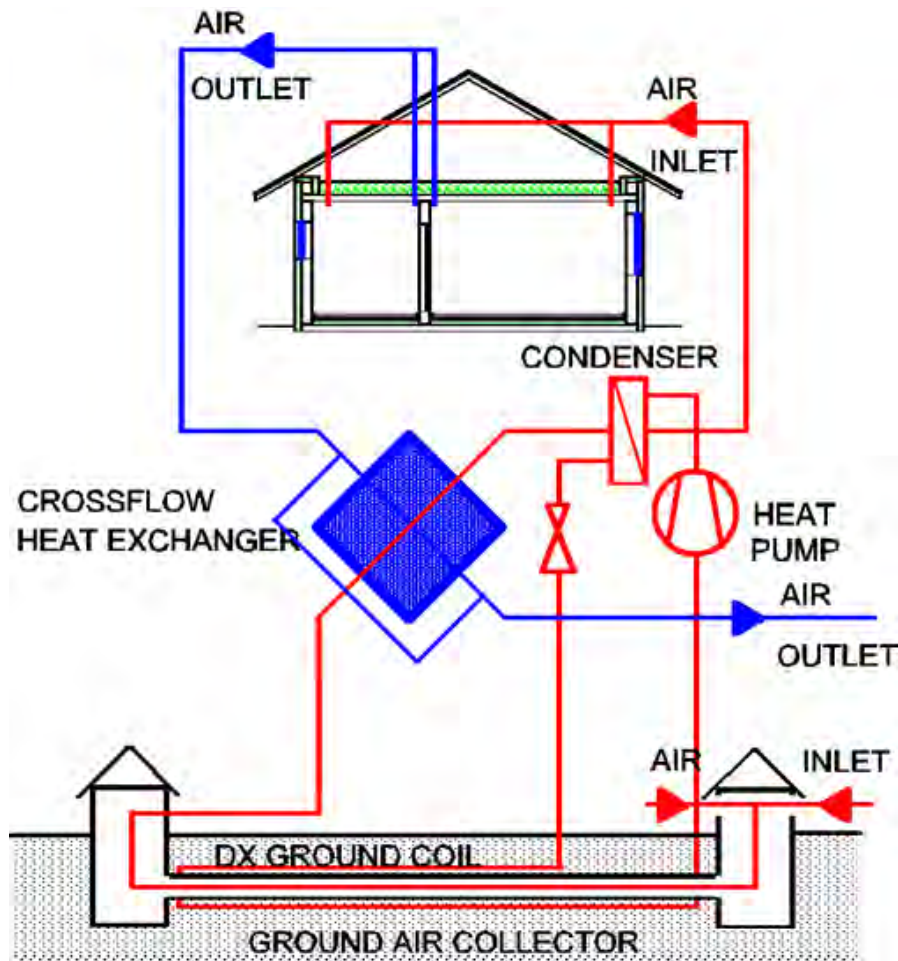

- C Compressor
- CO Condenser
- EV Evaporator
- A Accumulator
- THX Thermostatic Expansion Valve
- 4WV 4-Way Valve



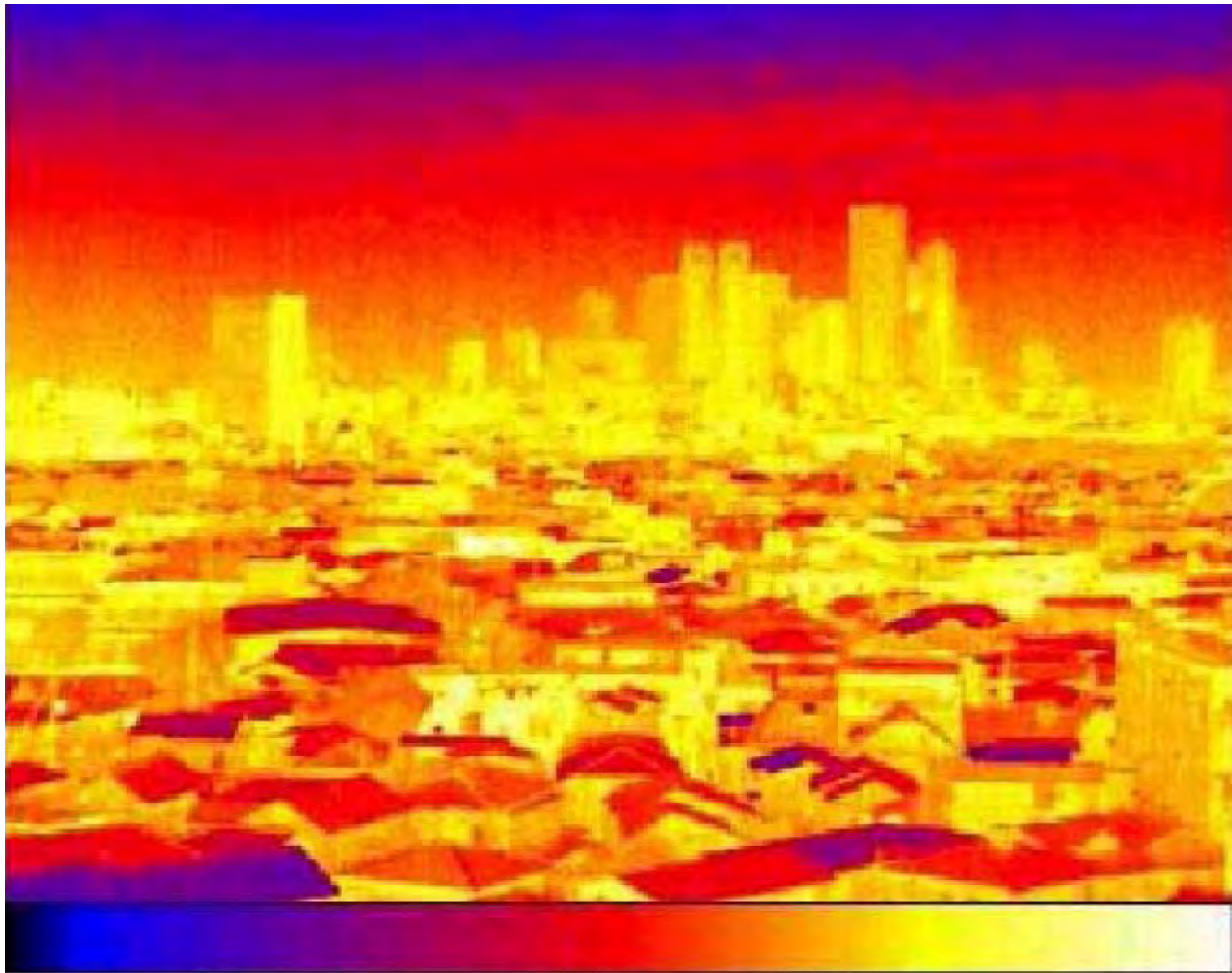

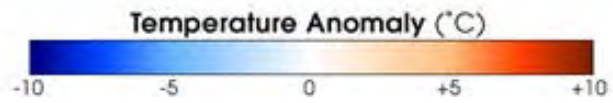
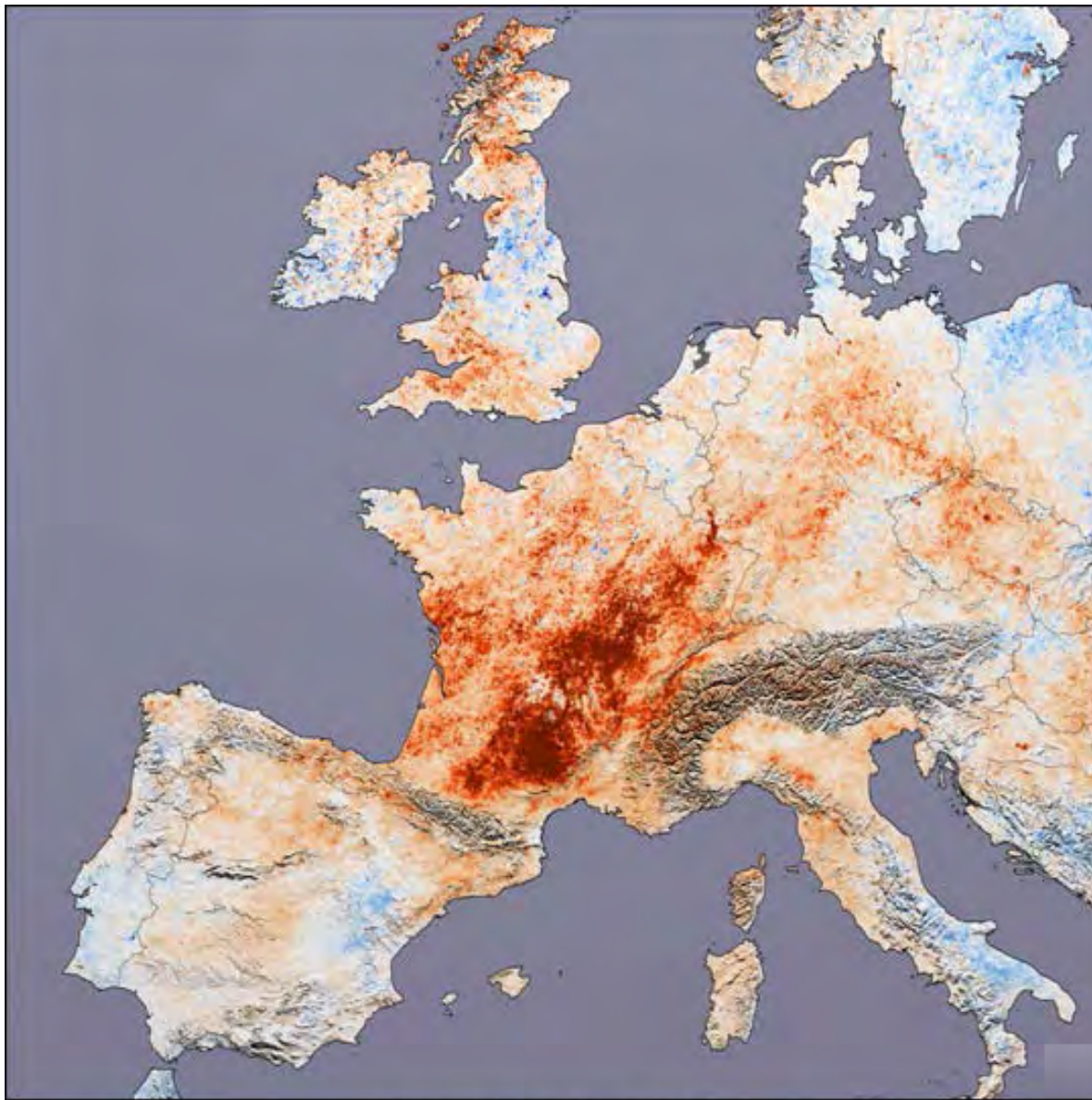



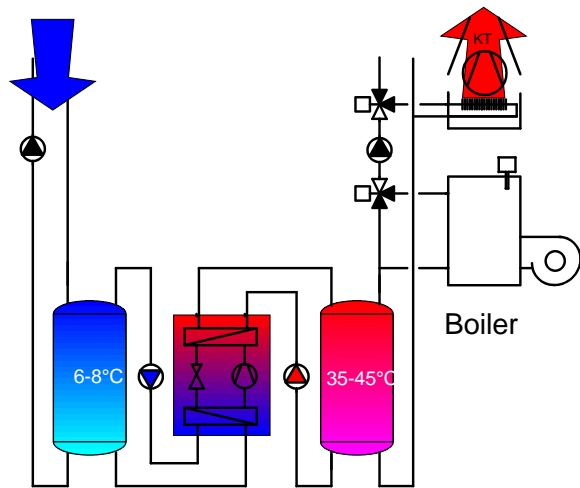
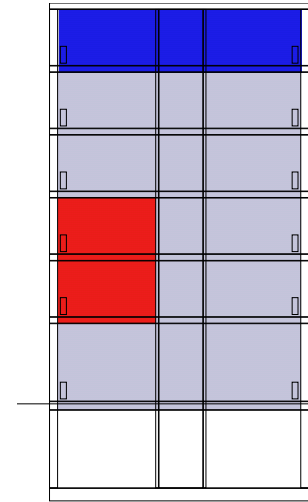
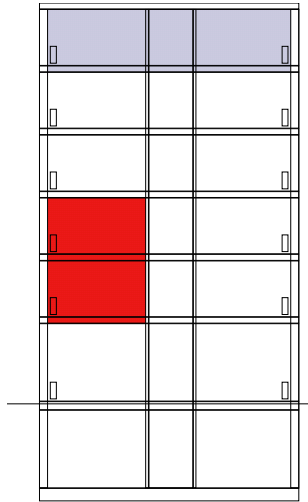
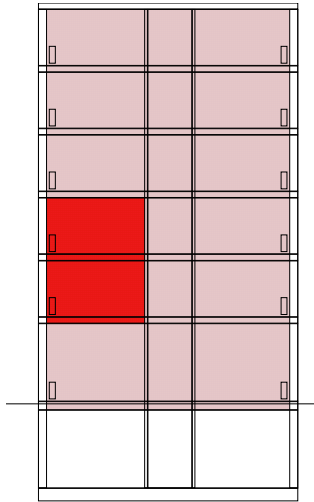

Cooling

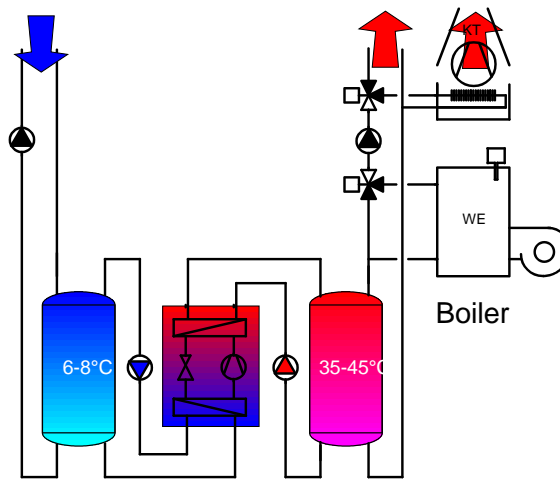

Cooling and Heating

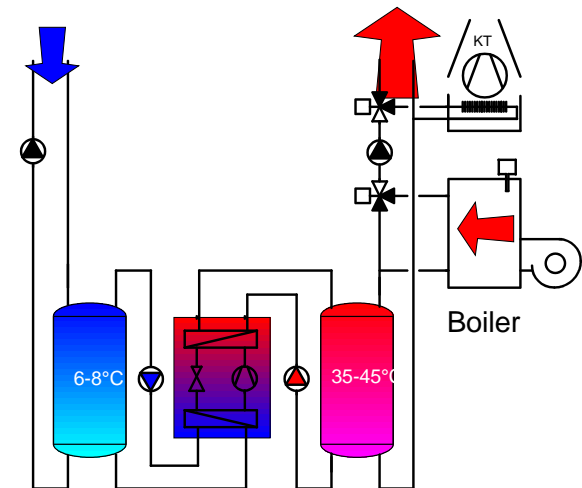

Heating



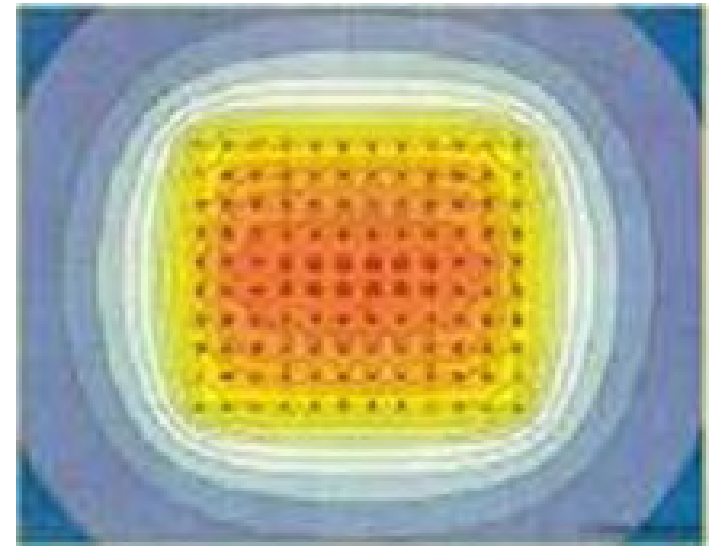
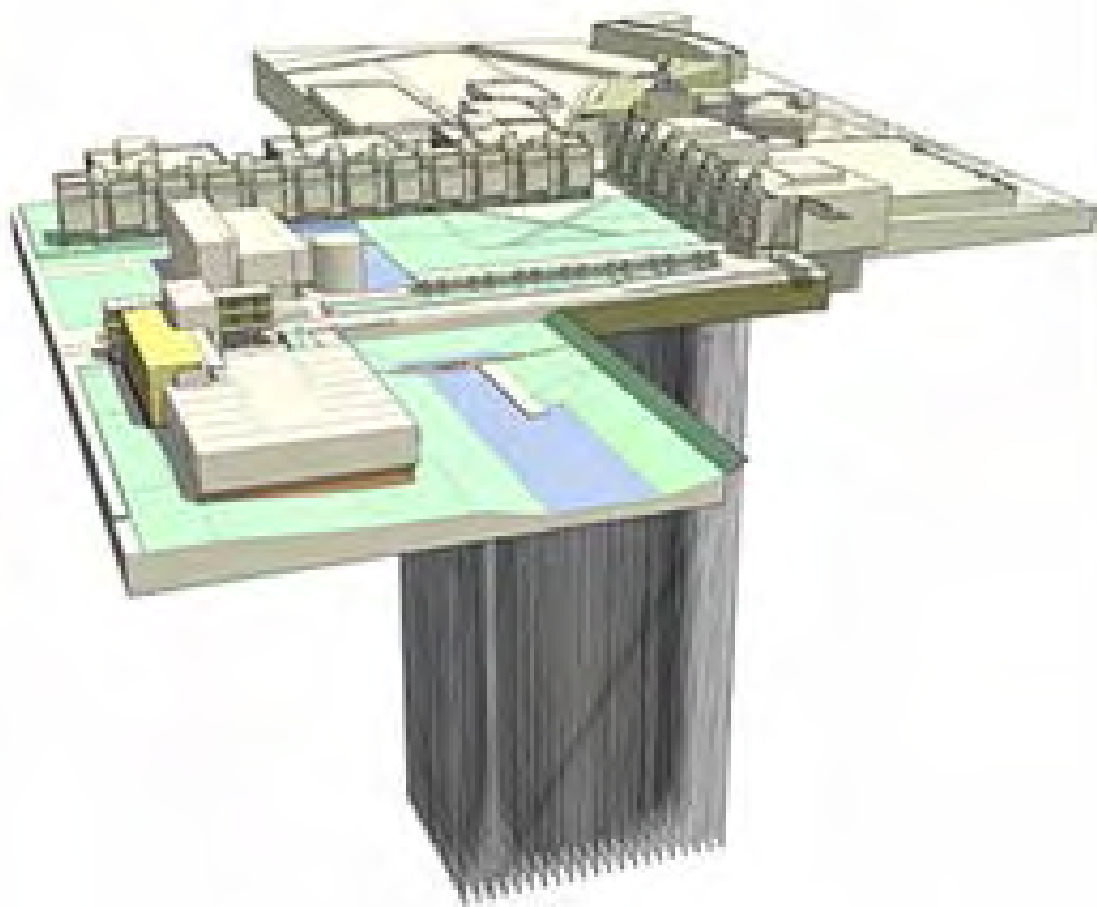

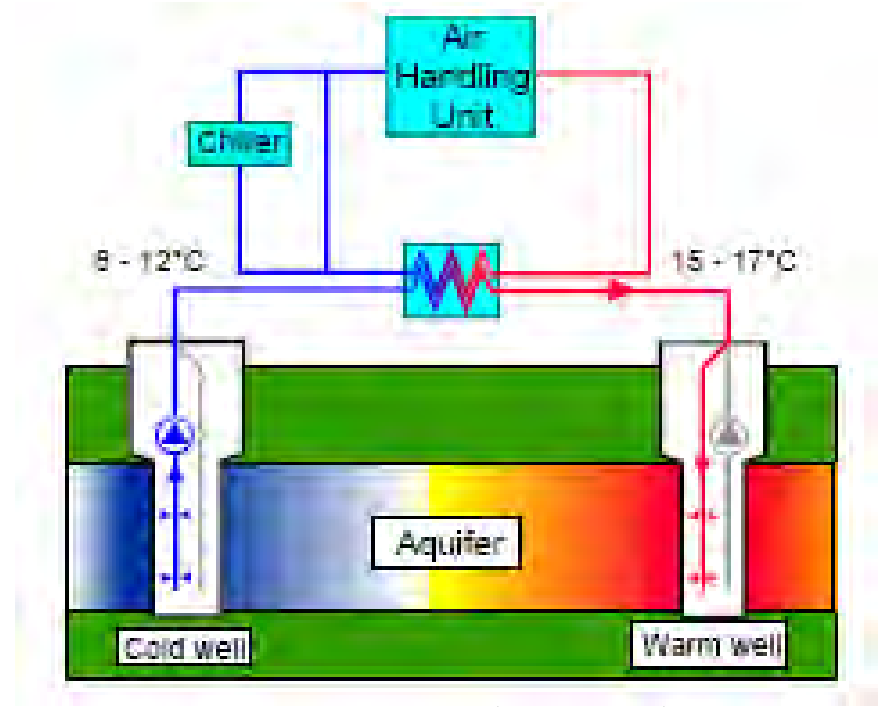
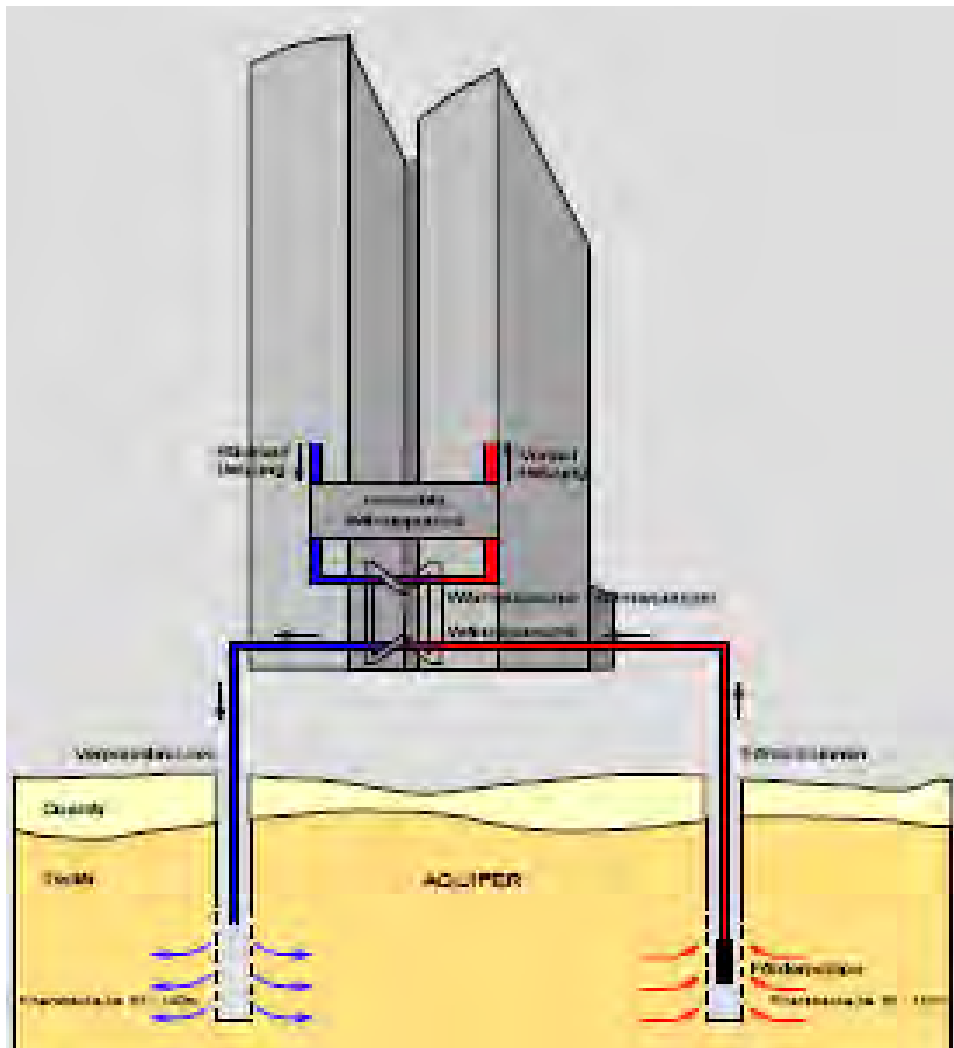

Gründung von Hochhäusern

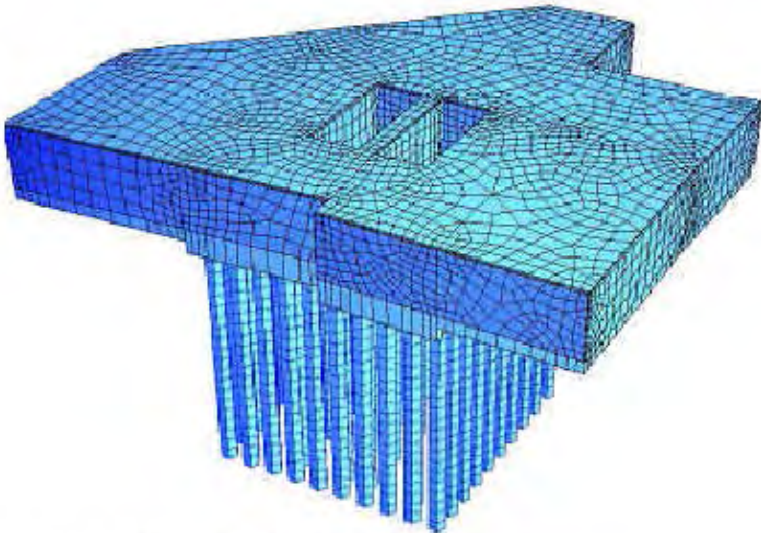
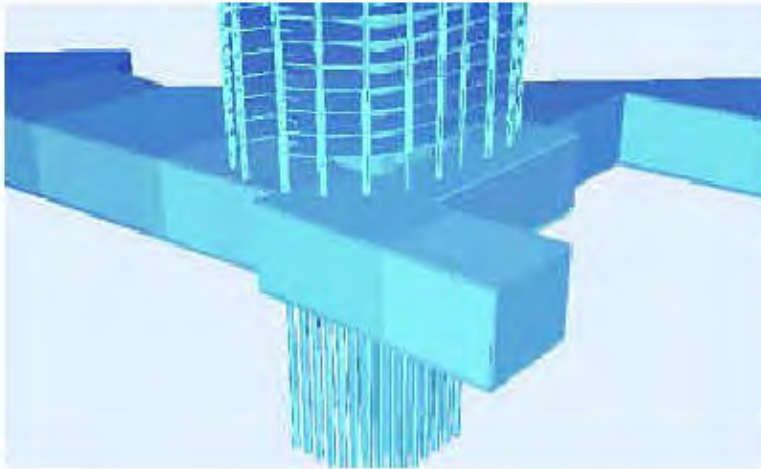

Hochhaus MAX, Frankfurt / Main
(A: Murphy/Jahn, I: Werner Sobek Ingenieure)

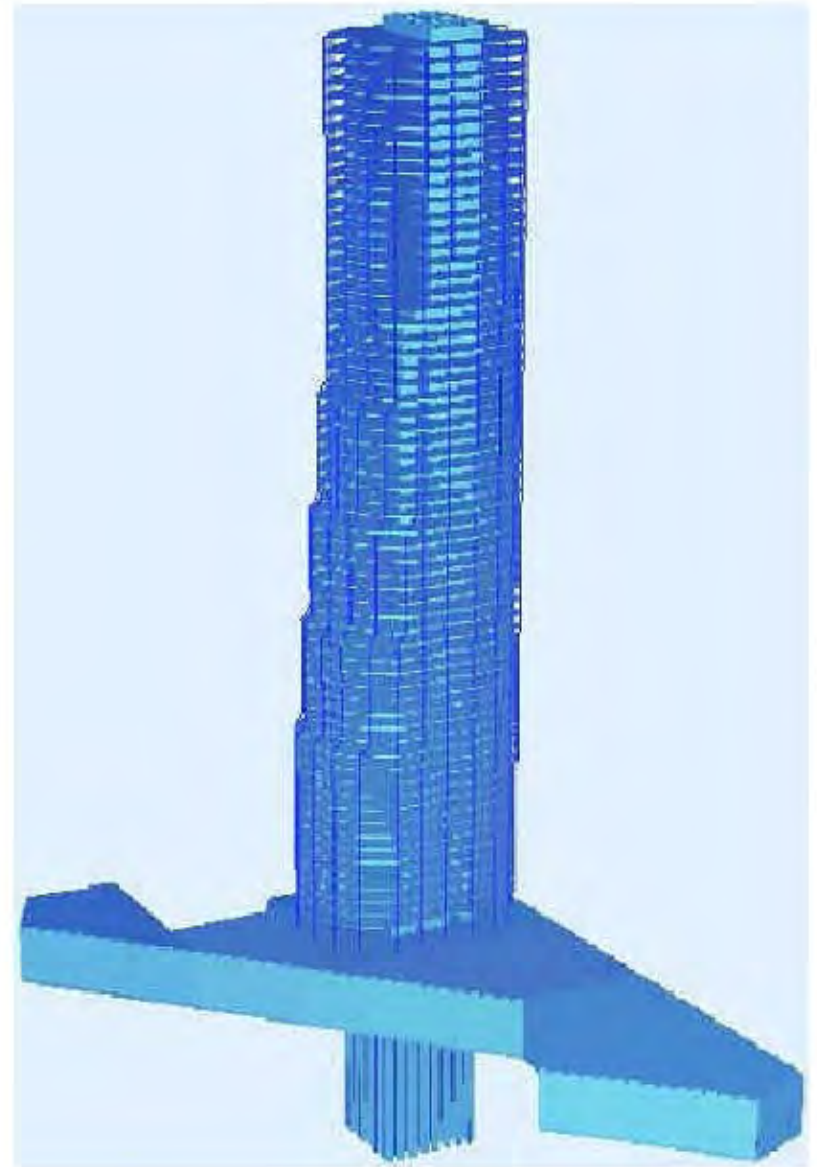

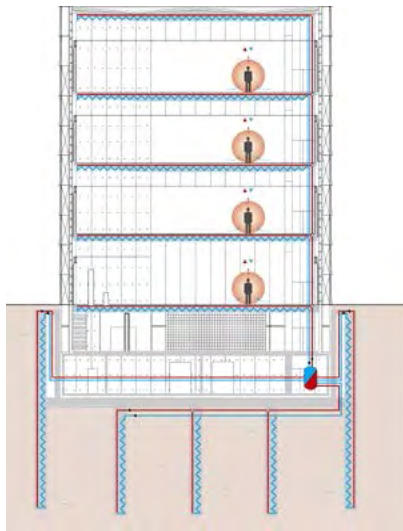

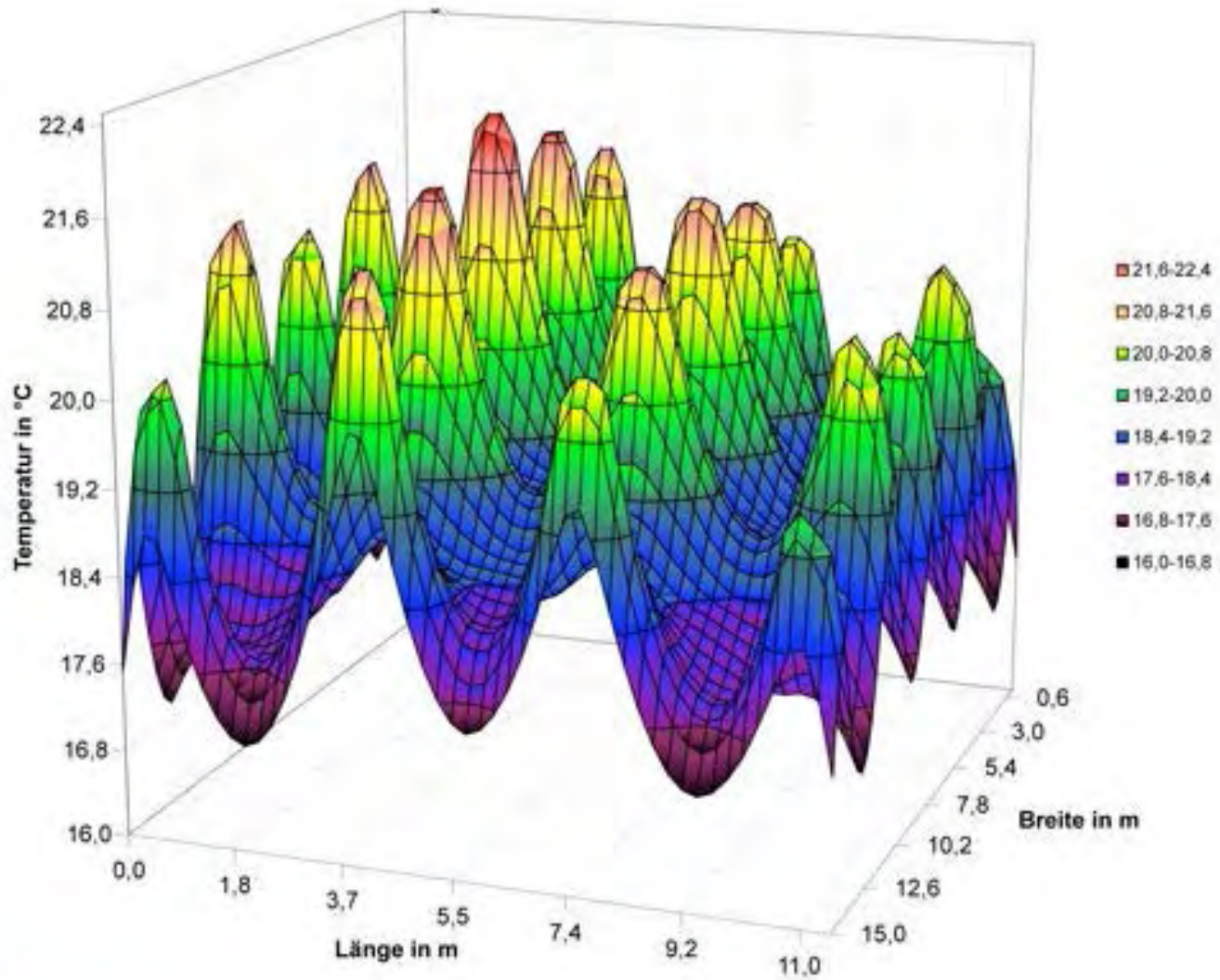

enercret[®]

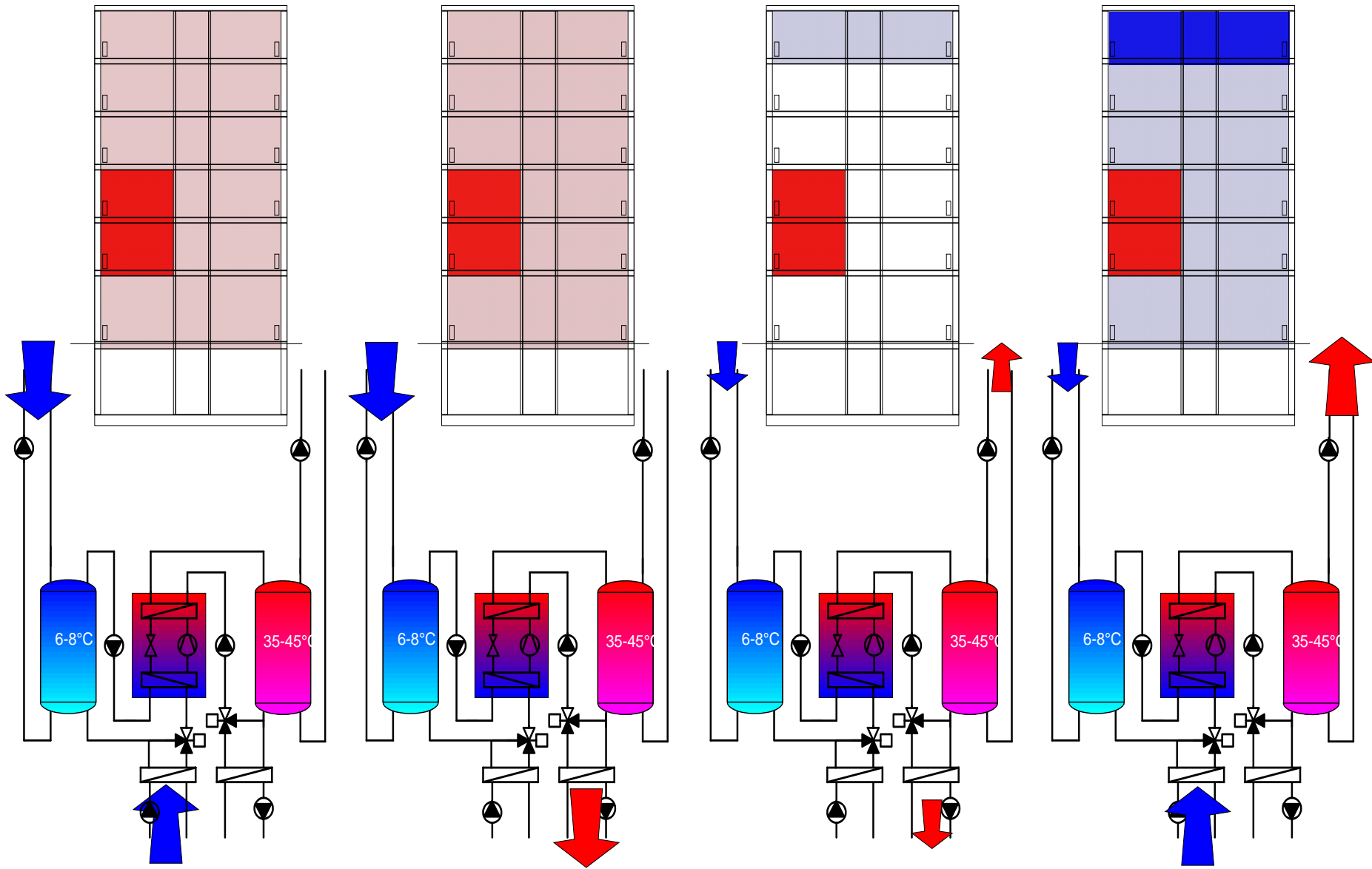

Direct Cooling

Cooling

Cooling and Heating

Heating

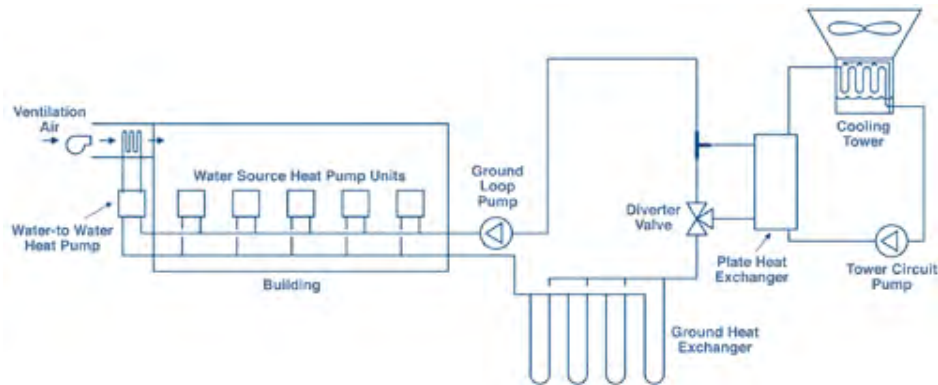
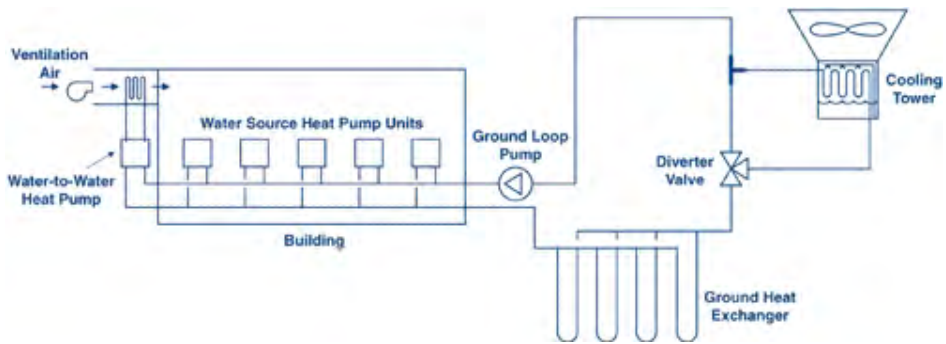

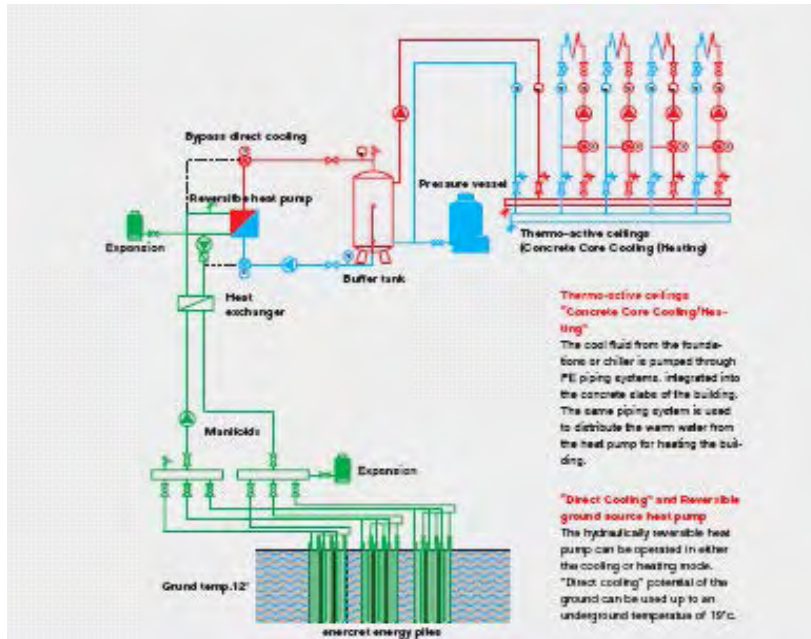



Réseau de distribution d'eau glacée

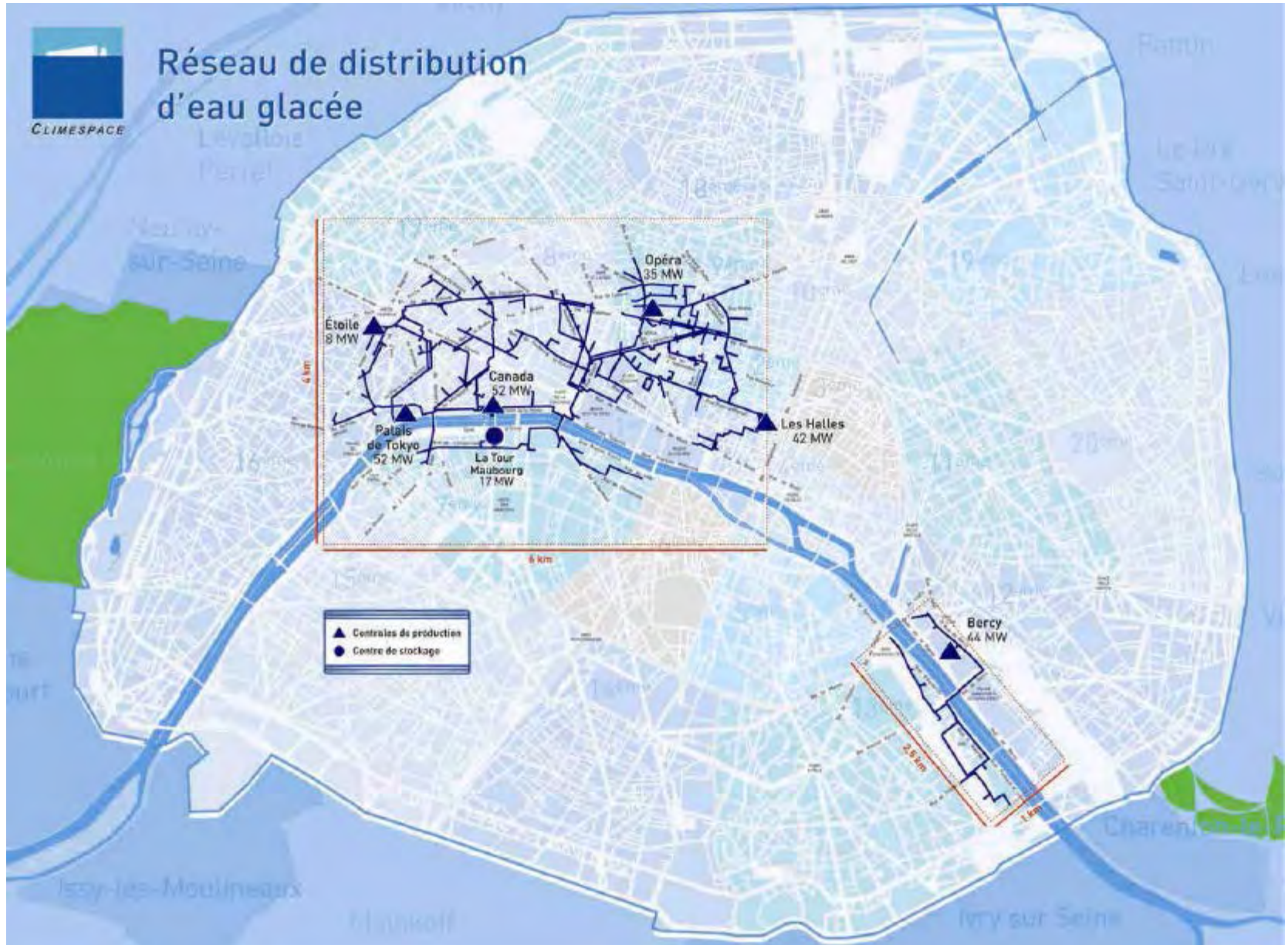

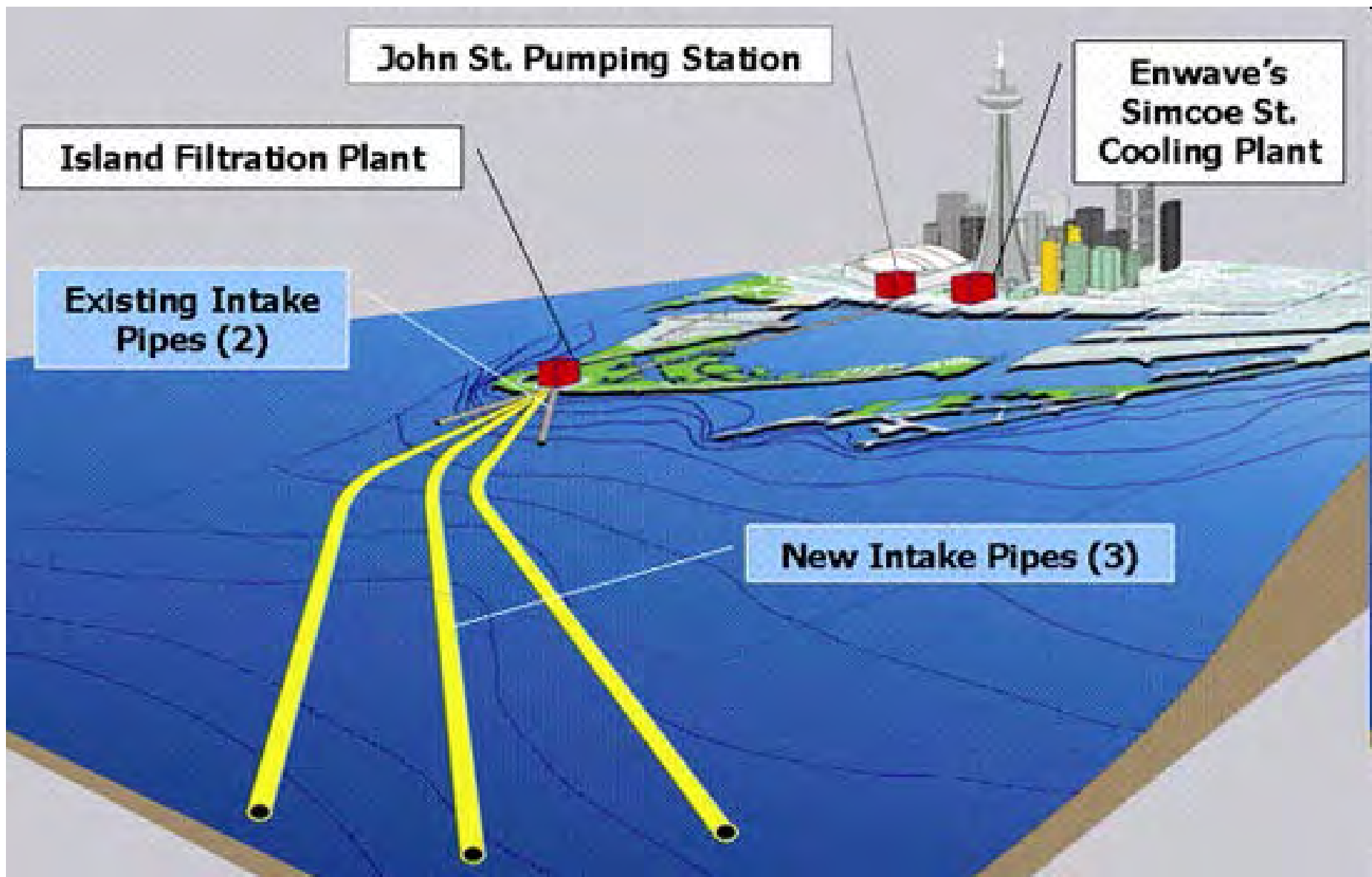









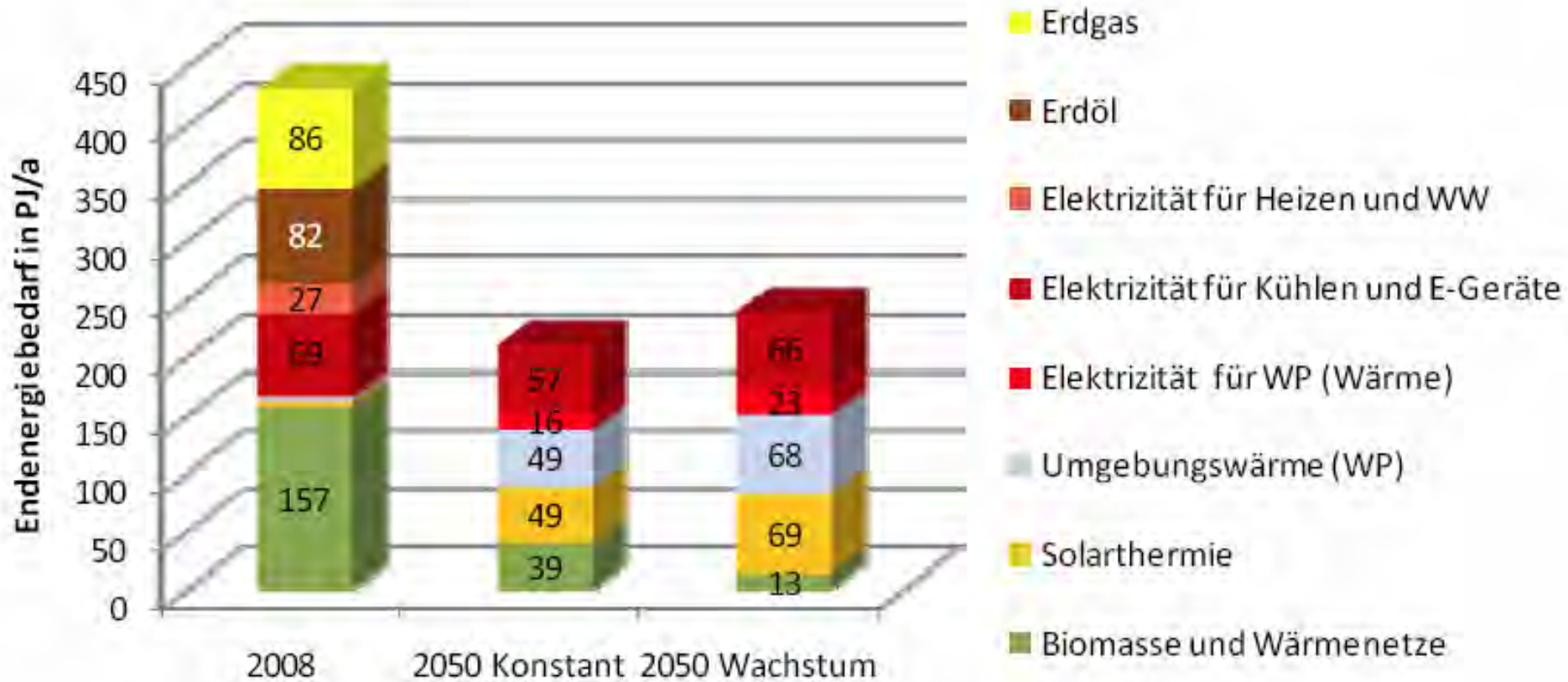

CO₂ Reductions by Scenario

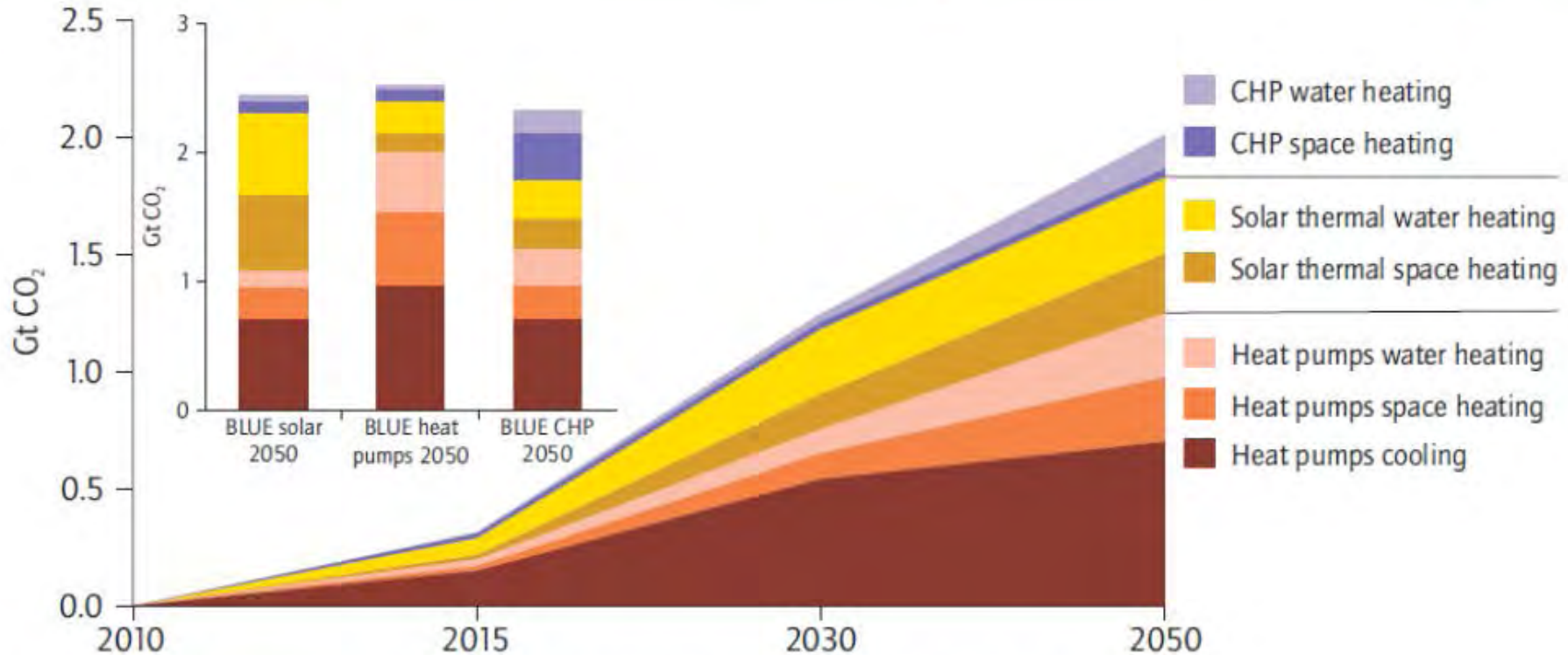

Note: Excludes the impact of improved building shells on reducing heating and cooling loads.



© OECD/IEA 2009

Low-carbon energy technology roadmaps



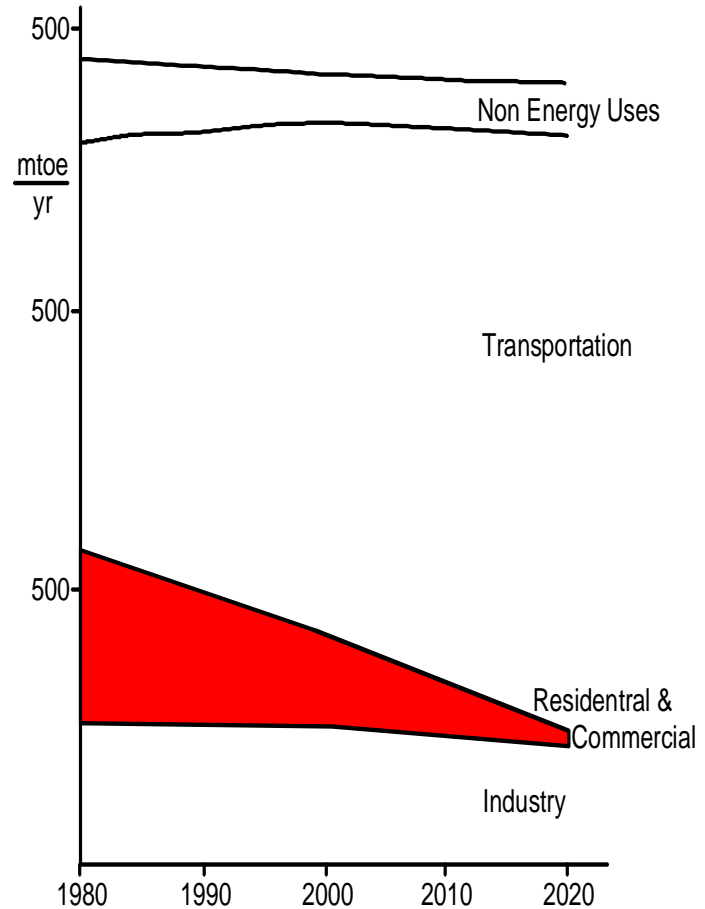
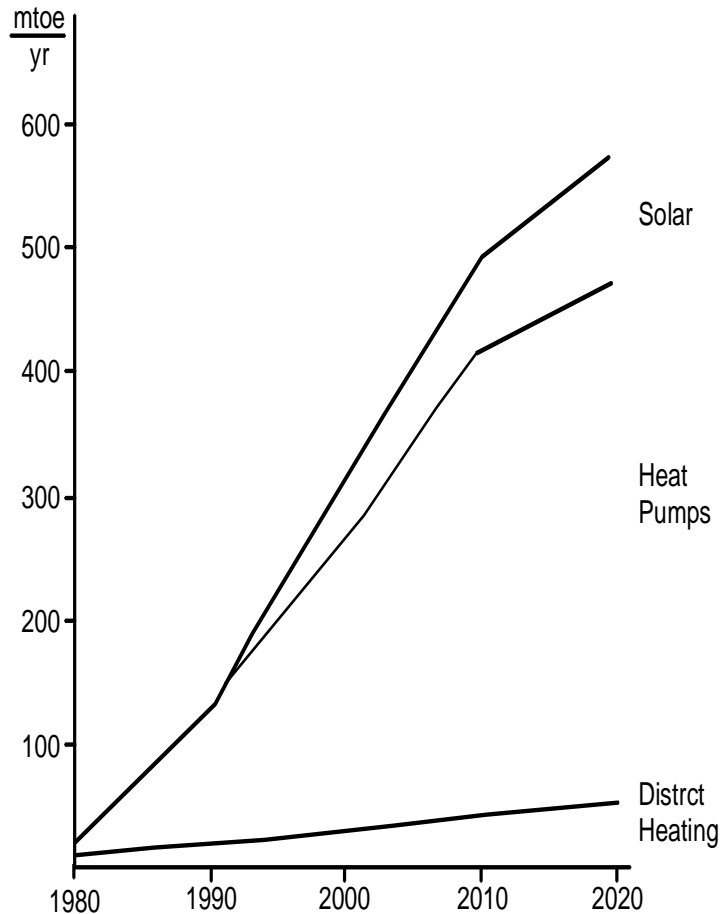

Strategy Study of the IEA 1980

Contributory factors in CO2 reduction, 2002-2030

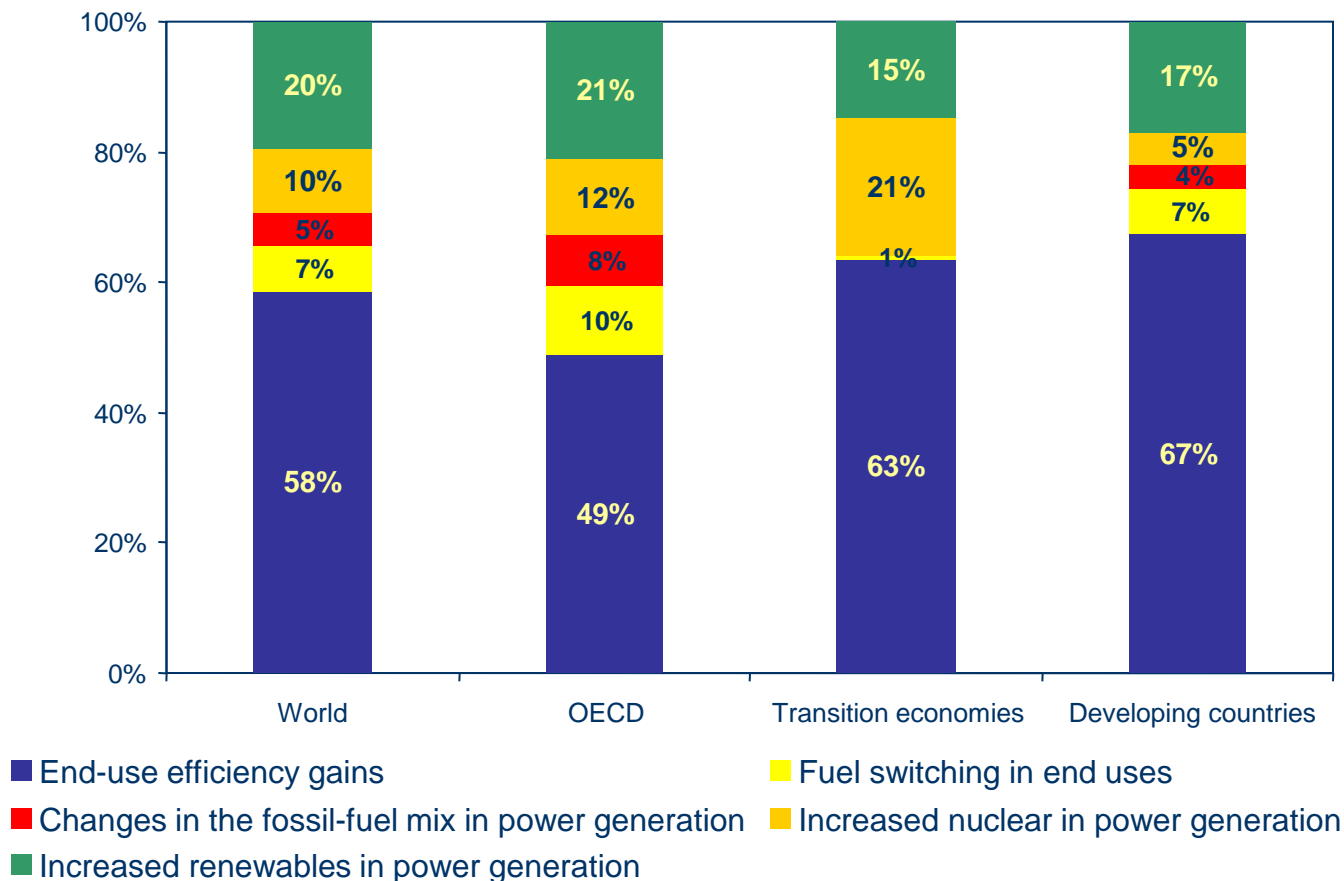

Improvements in end-use efficiency contribute for more than half of decrease in emissions, and renewables use for 20%