

Kombination von Biotreibstoffen der 1. und 2. Generation

Heike Frühwirth

4. Highlights der Bioenergie
Forschung

02.12.2010, Wien



Our future. Clean energy.

Outline

- **BDI – BioEnergy International AG**
- **Algae Biorefinery**
- **BioDiesel from Algae**
- **BioGas from Algae Biomass**
- **Summary & Outlook**

BDI – BioEnergy International AG

BDI Headquarters



BDI - BioEnergy International AG

Parkring 18

A-8074 Grambach/Graz

Austria / Europe

www.bdi-bioenergy.com

Diversified international Customer Base

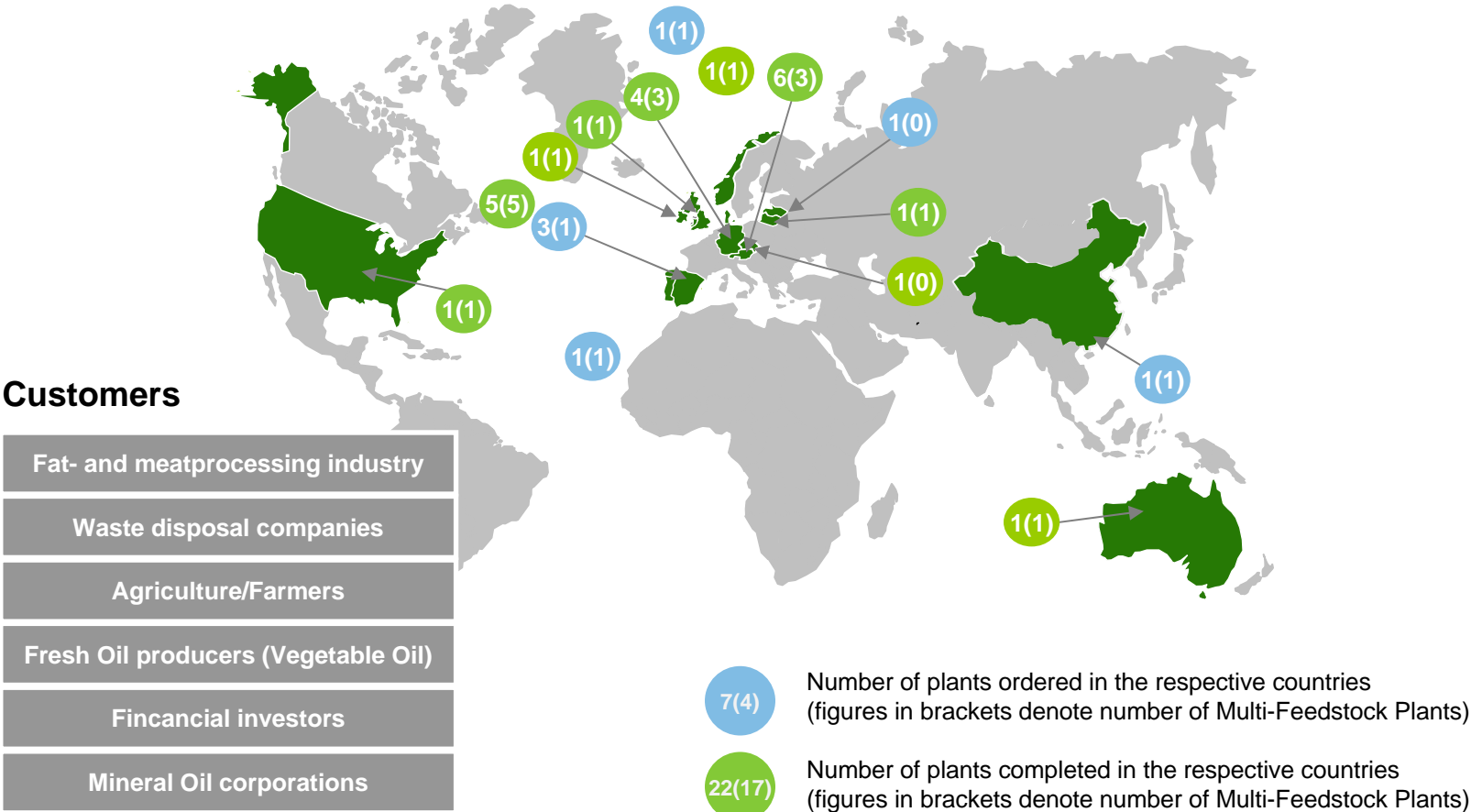

Biorefinery Concept

Products

Algae composition

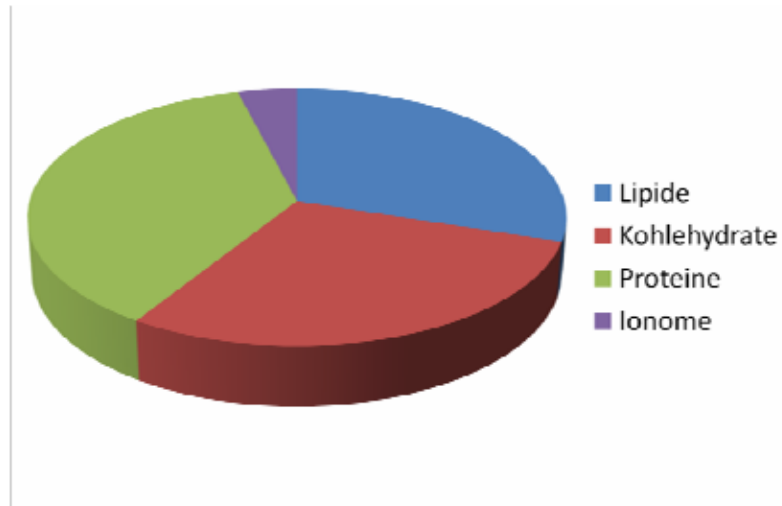

Possible energy products

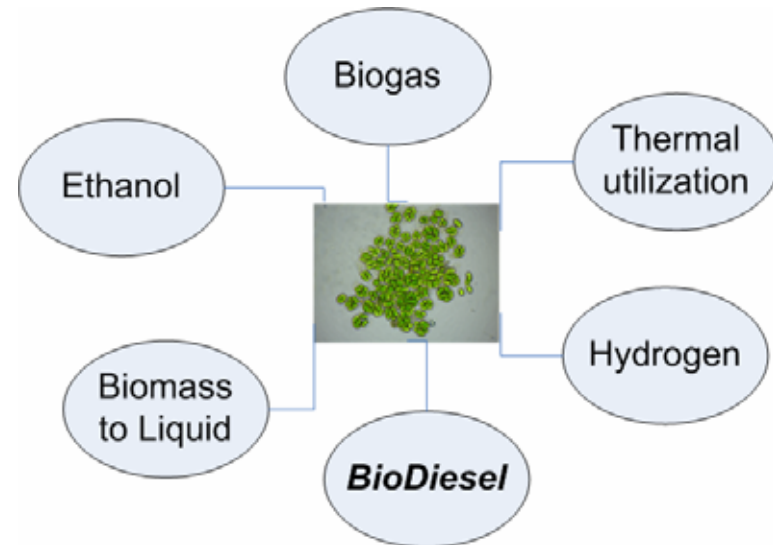

Overall Process

Biorefinery:

waste water
municipal waste
CO₂



BioDiesel
PUFA
Biogas

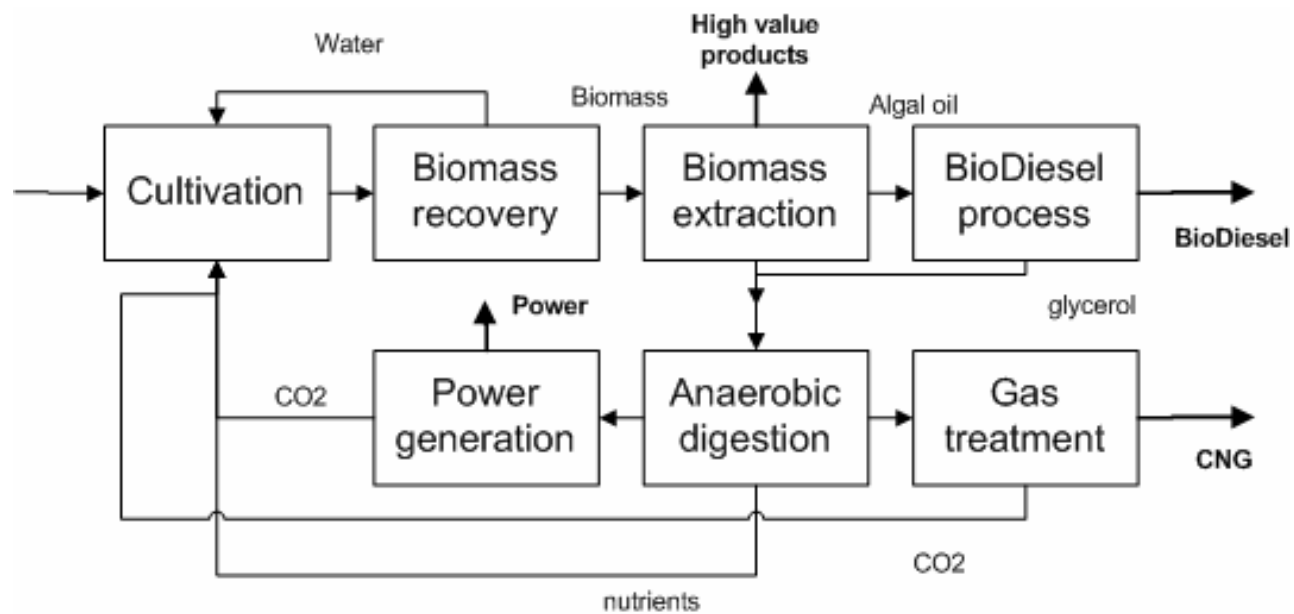

Overall Process

Algae cultivation

Biomass extraction

BioDiesel process

Anaerobic Digestion

Gas Treatment

Algae Cultivation

Algae cultivation

Prinziple

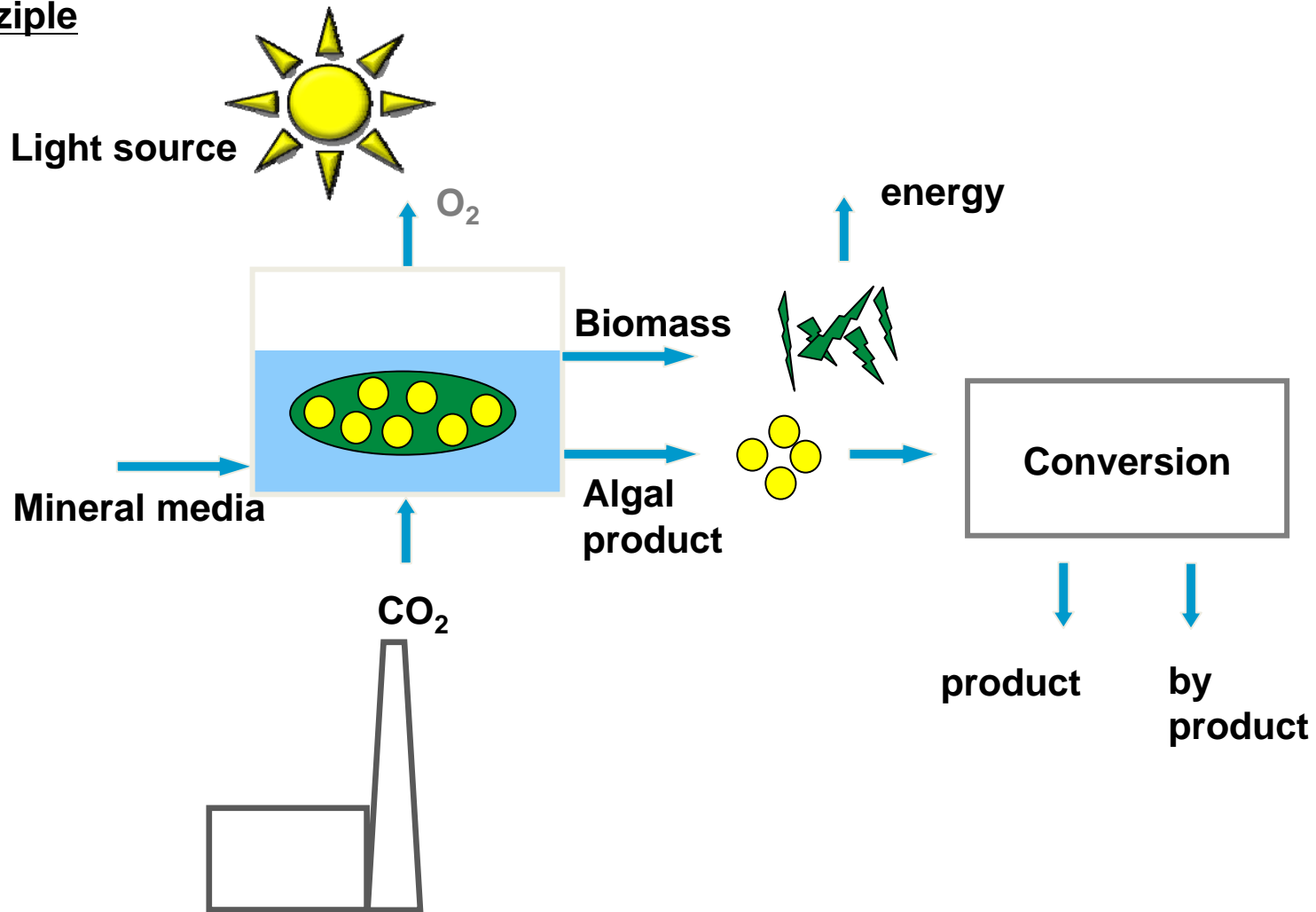

Algae cultivation

Open cultivation

Open ponds



Sapphire Energy, San Diego

Klötze, Subitec, Germany

Closed cultivation

Horizontal tubes



Airlift reactors

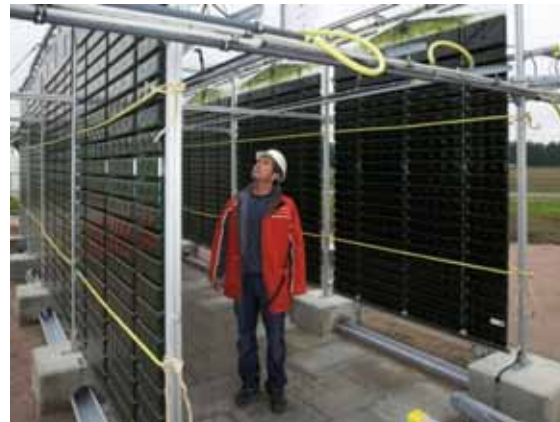

Novel concepts



NASA, US

Algae Cultivation

Energy balance

		Open Ponds	Flat Panel PBR	Tubular PBR
Volumetric Productivity	[kg/m ³ .d]	0,035	0,27	0,56
Biomass Concentration	[kg/m ³]	0,35	2,7	1,02
Energy Consumption	[W/m ³]	3,72	53	2500

$$Net_energy_ratio = \frac{\Sigma energy_produced}{\Sigma energy_requirements}$$

		Open Ponds	Flat Panel PBR	Tubular PBR
NER for Oil	[-]	3,05	1,65	0,07
NER for Biomass	[-]	8,34	4,51	0,2

O. Jorquera, A. Kiperstock Comparative energy LCA of microalgal biomass production in open ponds and PBR, Bioresource Technology, 2009

BioDiesel from Algae

BioDiesel Process

Transesterification

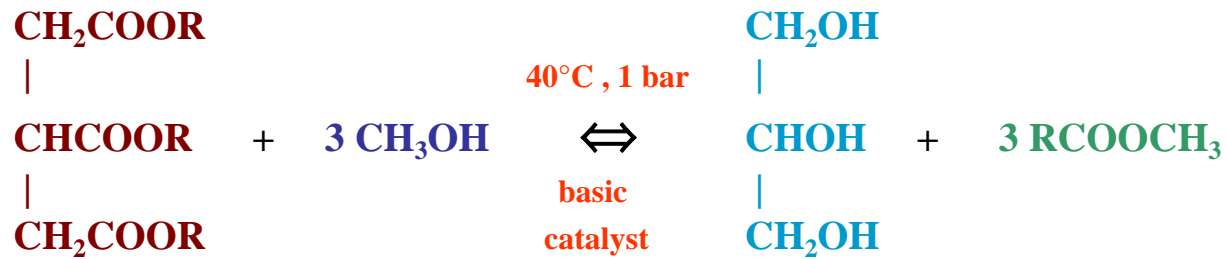

R = fatty acid chain

Esterification



BDI-Process – Flow chart

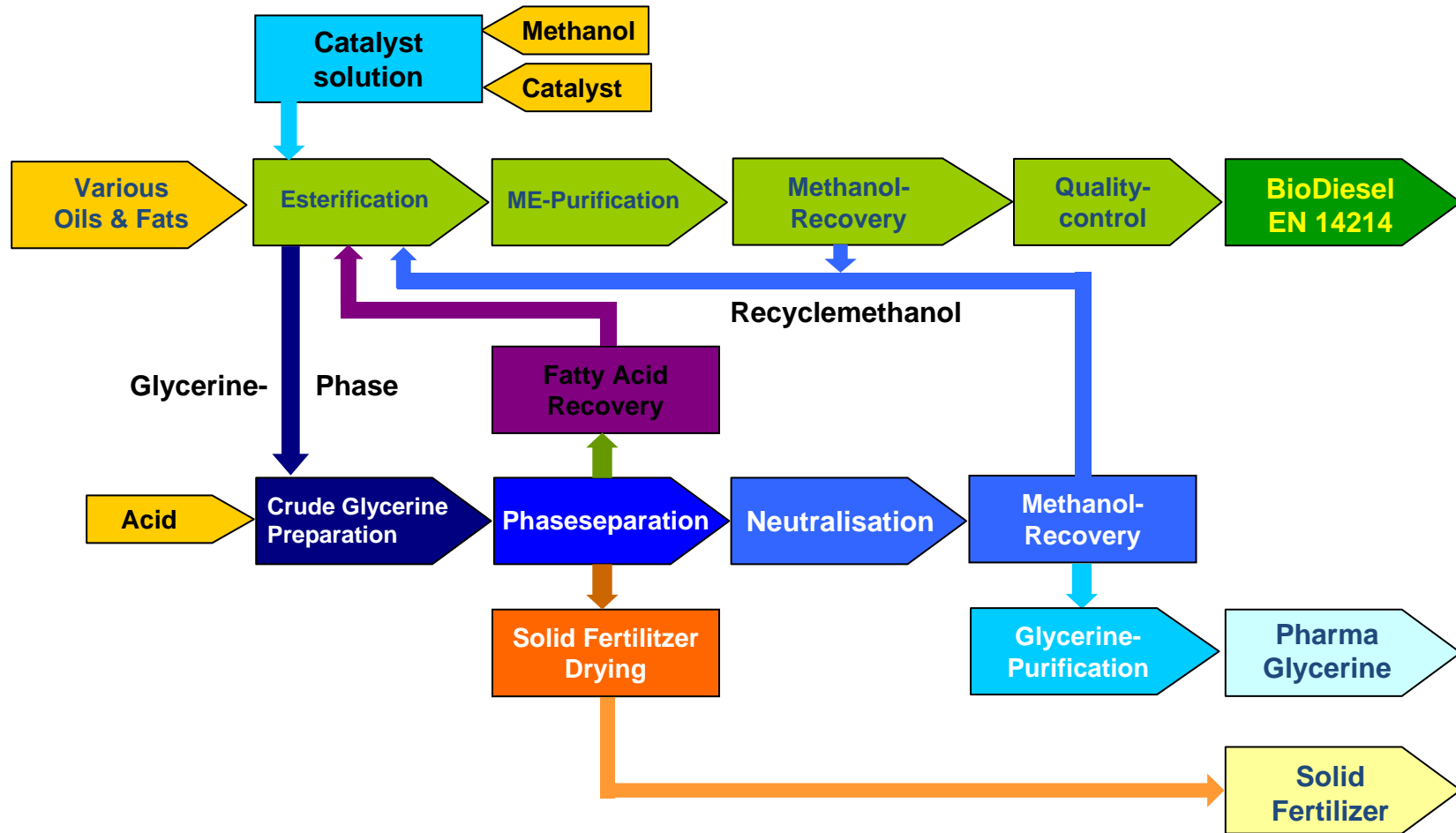

EN14214 – BioDiesel-Quality Standard

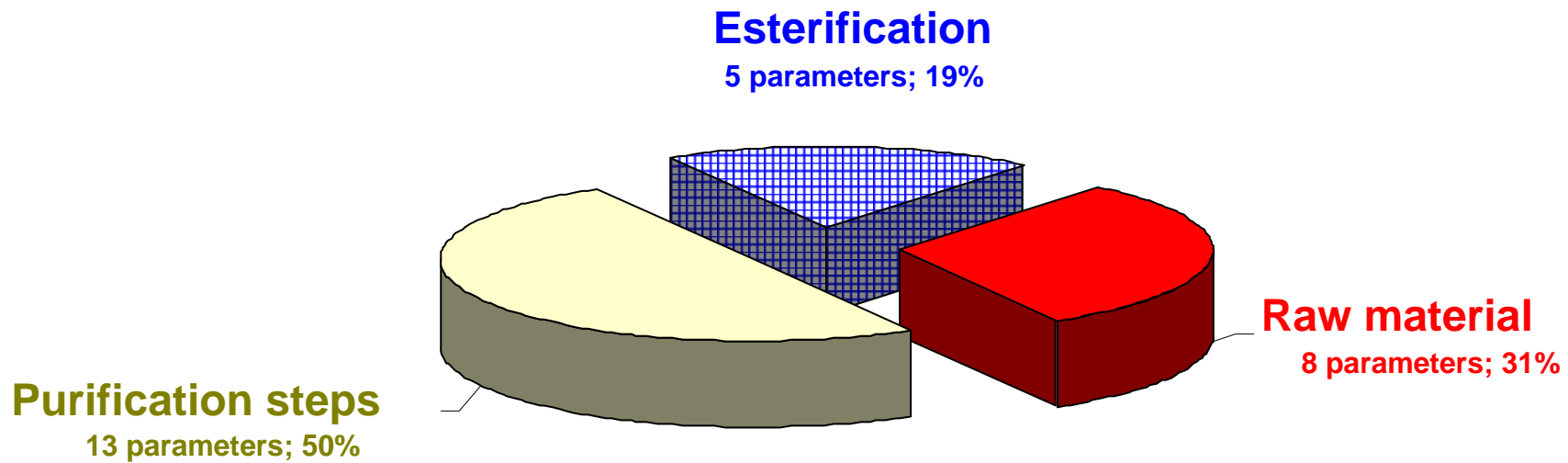

BioDiesel quality parameters influenced by raw material and process

EN14214 – BioDiesel-Quality Standard

Standard		Unit	U.S.A. ASTM D6751	EU EN 14214
Application			FAME	FAME
Date			2003	2009
Density	15°C	g/cm ³	-	0,86 – 0,90
Kinematic	20°C	mm ² /s	-	-
Viscosity	40°C	mm ² /s	1,9 – 6,0	3,5 – 5,0
Distillation recovery	90%	°C	< 360	-
Flashpoint		°C	≥ 93	≥ 101
Total Sulphur		mg/kg (ppm)	≤ 500 / 15	≤ 10
CCR	100%	%mass	≤ 0,05	-
	10%	%mass	-	≤ 0,30
Sulfat ash		%mass	≤ 0,02	≤ 0,02
Water content		mg/kg (ppm)	-	≤ 500
Impurities total		mg/kg (ppm)	-	≤ 24
Water & sediment			-	-
Corrosion (Cu)			-	1
Cetane No.			-	≥ 51
Neutralization No.			-	≤ 0,5
Oxidation stability		h	-	≥ 6
Methanol content		%mass	≤ 0,2-	≤ 0,20
Ester content		%mass	-	≥ 96,5
Monoglyceride		%mass	-	≤ 0,8
Diglyceride		%mass	-	≤ 0,2
Triglyceride		%mass	-	≤ 0,2
Free glycerol		%mass	≤ 0,02	≤ 0,02
Total glycerol		%mass	≤ 0,24	≤ 0,25
Iodine No.			-	≤ 120
Linolic acid ME		%mass	-	≤ 12
Polyunsaturated	>=4 db	%mass	-	≤ 1
Phosphor		mg/kg (ppm)	≤ 10	≤ 4
Alcaline metals	Na, K	mg/kg (ppm)	≤ 5	≤ 5
Earth alkaline metals	Ca, Mg	mg/kg (ppm)	≤ 5	≤ 5

Physical / chemical properties

Influenced by transesterification

Influenced by purification steps !!!

Algae Oil

Possible raw material for BioDiesel production:

Monoglycerides
Diglycerides
Triglycerides
Fatty acids

Possible composition of algae oil:

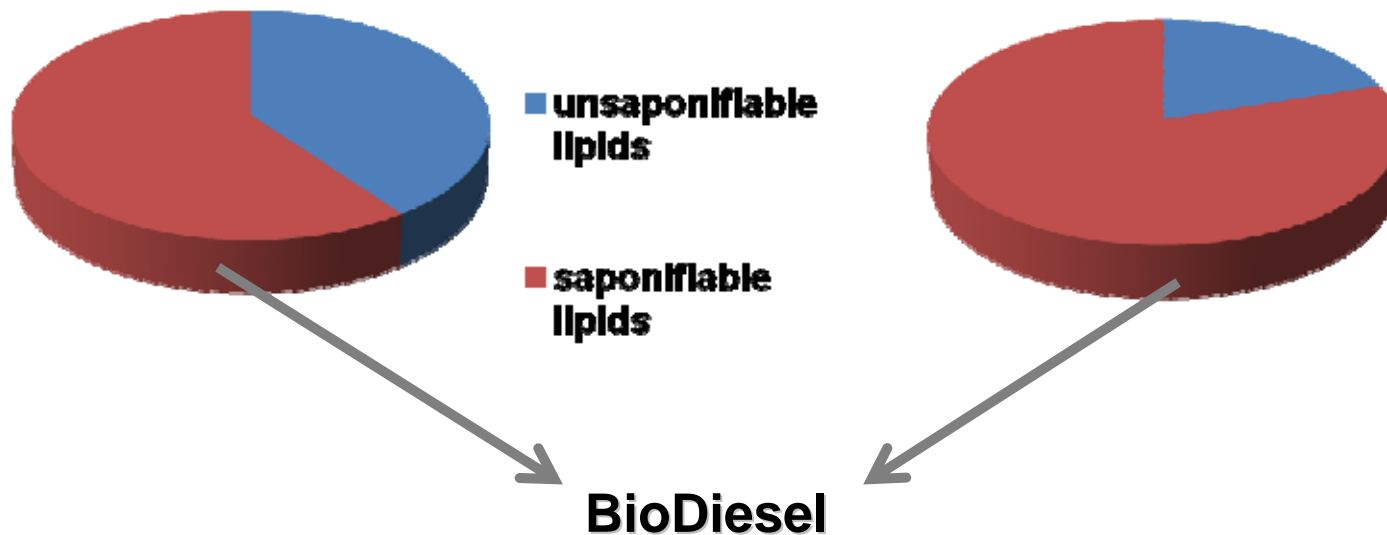

Content of saponifiable fraction within algae oil varies for different species and process conditions

Raw Material

Specification for raw material entering the BDI BioDiesel process

Unsaponifiable
Total fatty acids
Free fatty acid
Water
Insoluble substances
Phosphorous
Sulphur
Polymerised triglycerides
Polyethylene type plastics
Iodine number
Linolenic acid
Polyunsaturated fatty acid (≥ 4 double bonds)

Crude algae oils are off spec in various parameters

Algae Oil

Comparison of fatty acid profile of algae oil with different raw materials

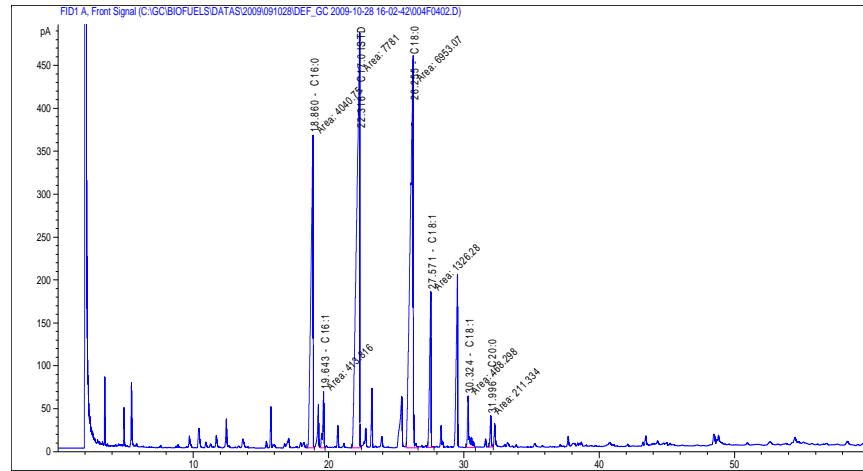

	Rapeseed	Animal fat	Algae oil
C14:0		4%	
C16:0	5%	27%	36%
C16:n		4%	8%
C18:0	1%	20%	9%
C18:1	55%	41%	38%
C18:2	34%	3%	7%
C18:3	4%	1%	3%

Algae BioDiesel CFPP Value

⇒ Cold Filter Plugging Point (CFPP) [°C]

Measure for cold behaviour, between cloud point and pour point.

CFPP = highest temperature a defined BioDiesel-volume is no longer able to pass a standardised filter in a certain time.

EN14214 mentions different limits for climate and saison

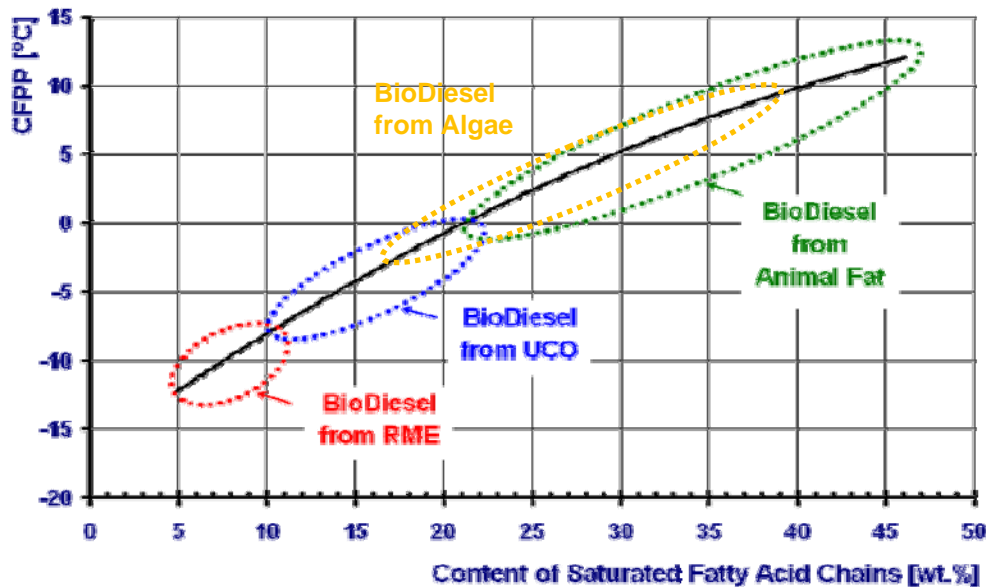

CFPP can be influenced by additives blending

Digestion of Algae Biomass

Biogas

- fermentation of algae paste - solid/liquid separation affects overall energy balance
- fermentation of biomass residues after extraction of oils or high value products

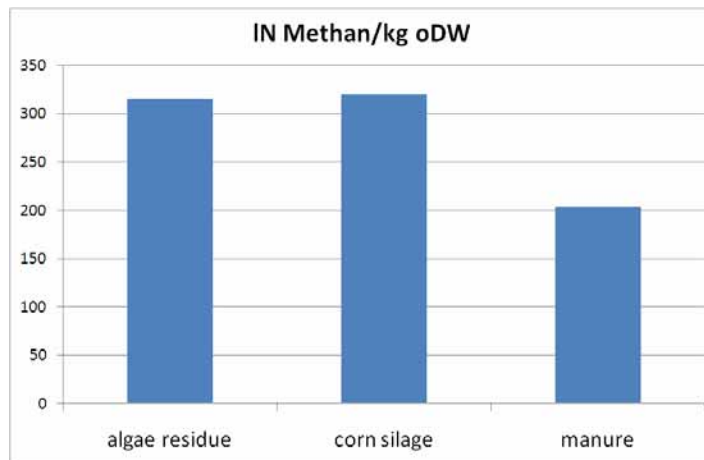

Average biogas rates 500 IN/kg_{oTS}

Relatively high Methane ratios 63% compared to corn silage: 53%



Algae Cultivation with CO₂ from Biogas

CO₂ source

fossil sources: incineration, power plants, cement industry.....

biogenic sources

CO₂ removal from gas mixtures => valorization of gas quality



Biogas (CH₄)

Biomass

Biogas (CH₄, CO₂)

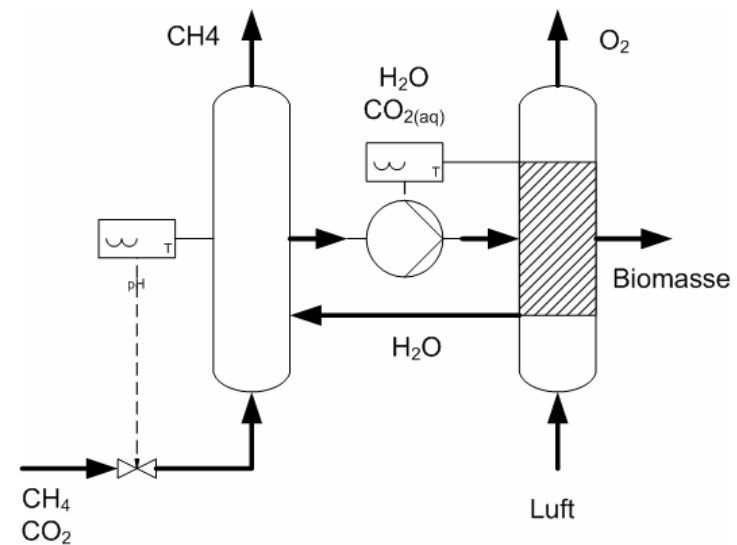

Outlook

Demonstration project AllGasOil:

**Industrial scale demonstration of sustainable algae cultures for biofuel production
2011-2016**

**European consortium:
algae cultivation in 10 ha algae facility in Spain**

**use of waste water, CO2 from Biogas
production of BioDiesel, Biogas, PUFA, power**

BioDiesel conversion in existing BDI plant



Summary

- **Microalgae high potential for added value and future energy products**
- **Algae oil is a challenging raw material for BioDiesel production: fatty acid profile, impurities**
- **Algae oil composition claims mature conversion technology for reaction & purification**
- **algae biorefinery reasonable combination of suitable processes**



This research is supported by the Austrian Climate and Energy Fund (NEUE ENERGIEN 2020) through the Austrian Research Promotion Agency



Our future. Clean energy.

Vergärungsversuche Algenbiomasse

Untersuchung von Algenbiomasse als Biogassubstrat

über Enbasys (Fa. ATRES)

- Intakte Biomasse
- aufgeschlossene Biomasse
- Vergleich mit Lit.-Werten

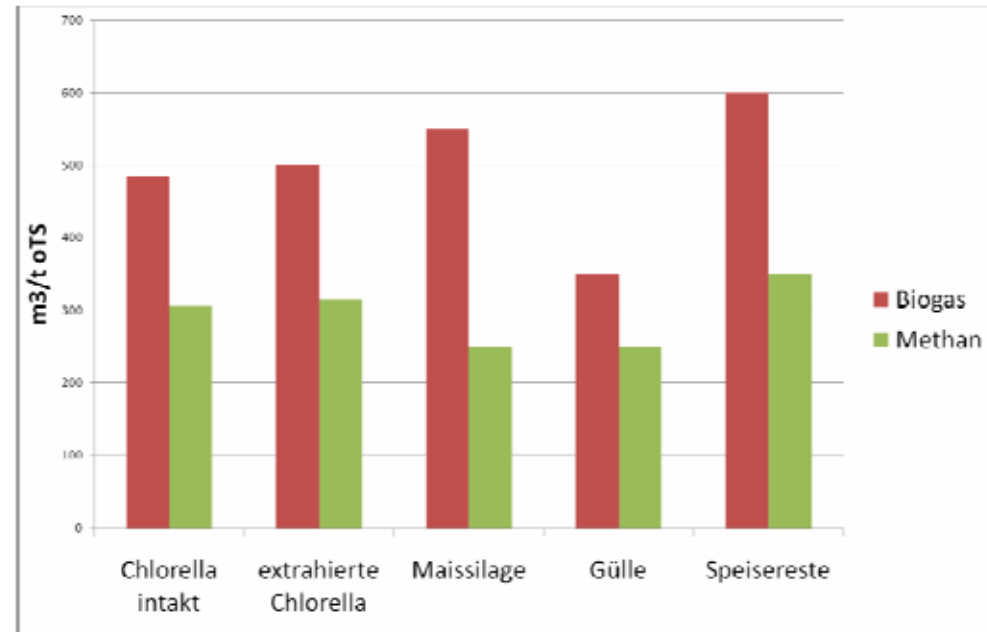

Relativ hohe Methananteile 63% (Vgl.: 53% Maissilage)

Umrechnung auf TS von Maissilage (35%) und Marktwert von 40€/t
=> überschlägig 120€/t Algenbiomasse erwirtschaftbar

Interessante Option für Extraktionsreste